



USES AND
RACOMMENDS



www.tmracing.it

TM Racing SpA - Via Fano, 6
61122 Pesaro - ITALY
Phone: +39 0721 25113

4T300FIMX22-M

MOTORE
ENGINE

24/11/2021



INFORMAZIONI GENERALI

Il presente catalogo serve per richiedere con esattezza le parti di ricambio.

Nelle ordinazioni indicare:

1) Il numero di matricola del Telaio che è stampigliato sul lato destro del canotto di sterzo. Nei modelli EN, SMR, SMR il numero di matricola è riportato anche su una targhetta posta sul lato sinistro (Vedi foto).

2) il numero di serie del Motore. E' posto sulla sinistra del motore tra la leva cambio e i coperchio accensione (Vedi foto).

3) Il codice dei particolari seguito dalla descrizione.

4) Il colore per i pezzi verniciati o comunque colorati.

Le indicazioni destra e sinistra si riferiscono ai lati del veicolo rispetto al senso di marcia.

Foto e disegni sono solo a scopo informativo e potrebbero non corrispondere esattamente alle caratteristiche dei prodotti.

GENERAL INFORMATION

The present spare parts catalogue enables one to order exactly the right spare part.

When ordering specify:

1) The frame serial number. It is embossed on the right side of the steering metal tube. In the EN, SMR and SMR models, the serial number is also stated on a plate positioned on the left hand side (See photo).

2) The engine serial numer. It is located on the left side of the engine between the gear lever and the ignition cover (See photo).

3) The part's code number followed but its description.

4) Indicate colour for painted or colored parts.

References to right and left apply to the vehicle in terms of its direction of movement.

Photos and drawings are for informational purposes only and may not exactly match the characteristics of the products.

NOTE – LEGENDA

MY

NOVITA' INTRODOTTA DIFFERENTE O NON PRESENTE NEL MODELLO DELL'ANNO PRECEDENTE

PART DIFFERENT OR NOT PRESENT IN THE REVIOUS YEAR MODEL

5M

MOTORE CON CAMBIO A 5 MARCE
ENGINE WITH 5 GEARS SPEED

6M

MOTORE CON CAMBIO A 6 MARCE
ENGINE WITH 6 GEARS SPEED

KS

MOTORE CON SOLO KICK STARTER
ENGINE WITH KICK STARTER ONLY

ES

MOTORE CON AVVIAMENTO ELETTRICO
ENGINE WITH ELECTRIC STARTER

X

RICAMBIO NON DISPONIBILE ALLA VENDITA
PART CAN NOT BE SOLD SEPARATELY

Le illustrazioni riportate in questo manuale sono fornite solo come riferimento e possono variare dal prodotto effettivo,

Dati indicativi soggetti a modifiche senza impegno di preavviso.

The illustrations in this manual are for reference only and may vary from the actual product.

All data are subject to modification without prior notice.

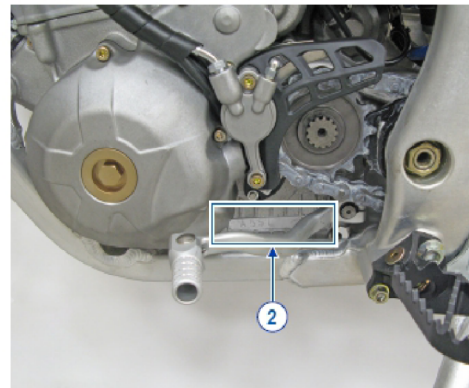
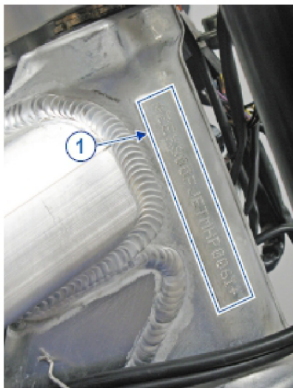



4T300FIMX22-M
MOTORE - ENGINE

SOMMARIO
TABLE OF CONTENTS

CILINDRO - PISTONE - CYLINDER - PISTON.....	4
TESTA - HEAD.....	6
MANOVELLISMO - CRANKSHAFT.....	9
MANOVELLISMO - CRANKSHAFT.....	11
DISTRIBUZIONE - VALVES COVER.....	13
LUBRIFICAZIONE - LUBRIFICATION.....	16
CARTER MOTORE - CLUTCH CASE.....	19
FRIZIONE - CLUTCH.....	21
COMANDO CAMBIO - GEARSHIFT MECHANISM.....	24
CAMBIO 6 MARCE - 6 GEARS GEARBOX.....	27
AVVIAMENTO PEDALE - KICK STARTER.....	30
ACCENSIONE ES - IGNITION ES.....	32



4T300FIMX22-M
MOTORE - ENGINE

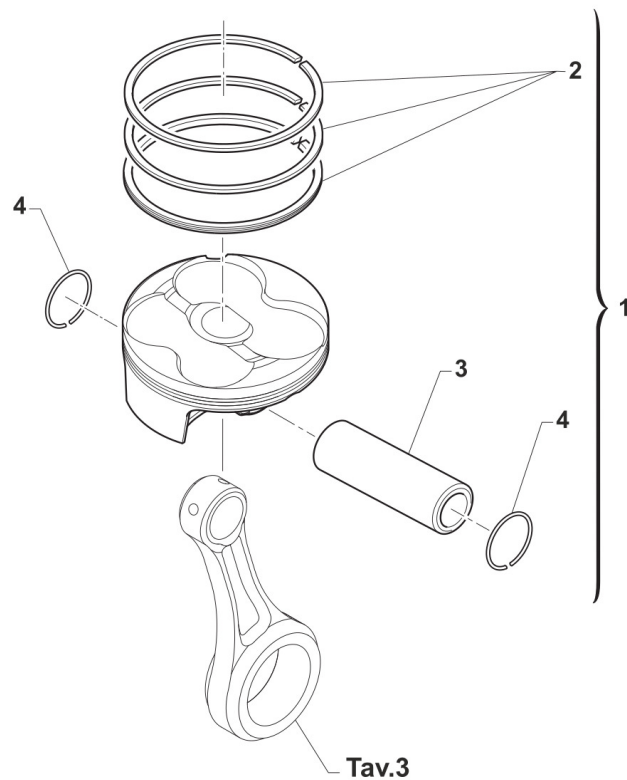

CILINDRO - PISTONE
CYLINDER - PISTON

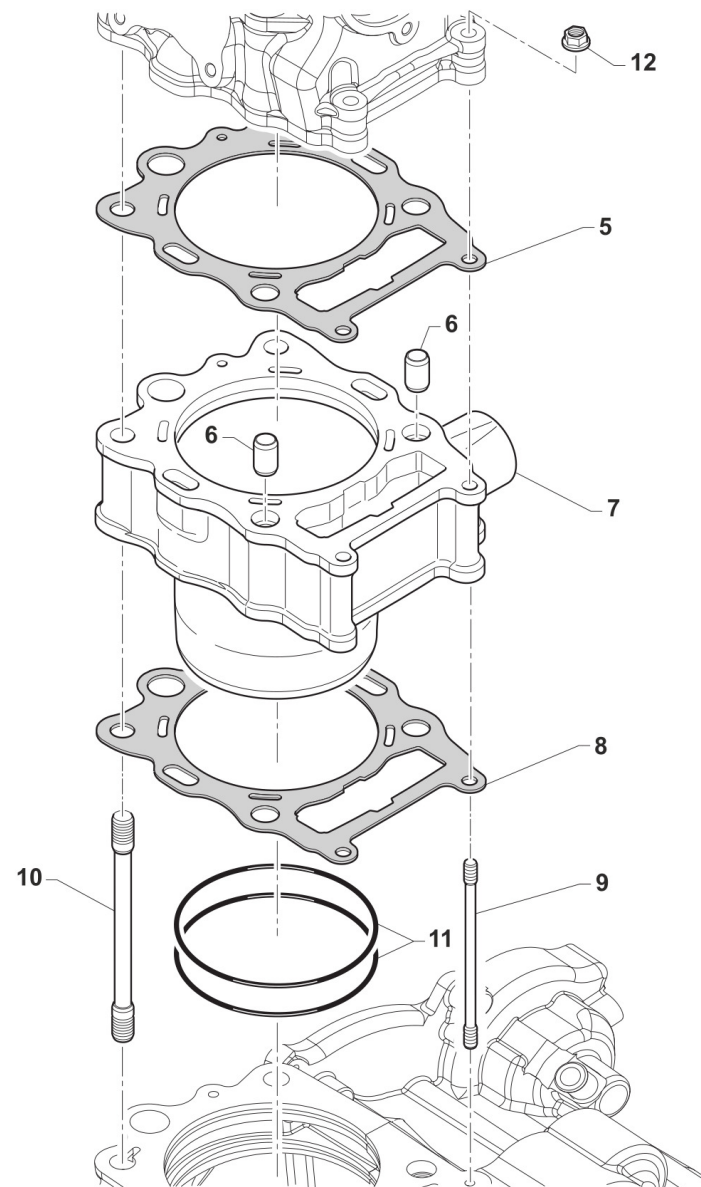

TM0001



4T300FIMX22-M
MOTORE - ENGINE

CILINDRO - PISTONE
CYLINDER - PISTON

1

Pos.	Codice	Q.tà	Note	Descrizione	Description
1	F10868.95	1		PISTONE Ø 80,95 C.19,3 300 4T Fi Twin CPL	PISTON Ø 80,95 C.19,3 300 F.S.TWIN Fi ASSY
1	F10868.96	1		PISTONE Ø 80,96 C.19,3 300 Fi Twin CPL	
1	F10868.97	1		PISTONE Ø 80,97 C.19,3 300 Fi Twin CPL	
1	F10868.98	1		PISTONE Ø 80,98 C.19,3 300 Fi Twin CPL	
2	F11409	1		KIT SEGMENTI D.81 NPR	RINGS KIT D.81 NPR
3	F09396.2	1		SPINOTTO 16X10.5X36 BIC.DLC S2	PISTON PIN 16X10.5X36 DLC
4	F09385	2		ANELLINO D.16X1 VP	CIRCLIP D. 16X1 VP
5	F05859.1	1		HEAD GASKET D. 81 3 LAYERS CH	
6	F26428	2		GRANO RIFERIMENTO 12X13 F10.2	GRUB SCREW 12X13 H.10,2mm
7	F01729	1		Cilindro Ø81 h=34,8 mm 300 REPLICA	
8	F05856.1	1		GUARNIZ.CIL/BAS SP.0,2 EVO3 M3	GASKET CYL. TH.0,2 EVO3 M3
8	F05856.2	1		GUARNIZ.CIL/BAS SP.0,3 EVO3 M3	GASKET CYL. TH.0,3 EVO3 M3
8	F05856.3	1		GUARNIZ.CIL/BAS SP.0,4 EVO3 M3	GASKET CYL TH.0,4 EVO3 M3
8	F05856.4	1		GUARNIZ.CIL/BAS SP.0,5 EVO3 M3	GASKET CYL. TH.0,5 EVO3 M3
9	F49875	2		PRIGIONIERO M6X1 /=83 MM A10.9	STUD M 6X1 83MM
10	F49045	4		PRIGIONIERO M10X1,25 L=142,5	STUD M 10X1,25 142,5 MM
11	F12357.1	2		O RING ORM 91,0X2,0 VITON	
12	49676	2		DADO M 6X1 FLANG. AUTOBL.ACC.	NUT, FLANGED M6 X 1 S.B.



4T300FIMX22-M
MOTORE - ENGINE

TESTA
HEAD

Pos.	Codice	Q.tà	Note	Descrizione	Description
1	F30061	1		COPERCHIO TESTA 250Fi MX MY18	CYLINDER HEAD COVER 250Fi F.S. MX M18->
2	49482	4		VITE TCEI 6X14 UNI 5931	BOLT TCEI 6X14
3	F12364	1		O RING 155X2	O-RING 155 X 2
4	F12345.1	1		O RING ORM 24,0X1,5 VITON	O-RING 24 X 1,5
5	49702	1		GRANO 5X 6 VALV.SC.MARTELLETTO	GRUB SCREW 5 X 6 INLET VALVE
6	F26603.255	1		PASTIGLIA REGOLAZ. GIOCO Ø 7,26 Sp. 2,55	SHIM, VALVE ADJUSTING Ø 7,26 TH. 2,55
6	F26603.260	1		PASTIGLIA REGOLAZ. GIOCO Ø 7,26 Sp. 2,60	SHIM, VALVE ADJUSTING Ø 7,26 TH. 2,60
6	F26603.265	1		PASTIGLIA REGOLAZ. GIOCO Ø 7,26 Sp. 2,65	SHIM, VALVE ADJUSTING Ø 7,26 TH. 2,65
6	F26603.270	1		PASTIGLIA REGOLAZ. GIOCO Ø 7,26 Sp. 2,70	SHIM, VALVE ADJUSTING Ø 7,26 TH. 2,70
6	F26603.275	1		PASTIGLIA REGOLAZ. GIOCO Ø 7,26 Sp. 2,75	SHIM, VALVE ADJUSTING Ø 7,26 TH. 2,75
6	F26603.280	1		PASTIGLIA REGOLAZ. GIOCO Ø 7,26 Sp. 2,80	SHIM, VALVE ADJUSTING Ø 7,26 TH. 2,80
6	F26603.285	1		PASTIGLIA REGOLAZ. GIOCO Ø 7,26 Sp. 2,85	SHIM, VALVE ADJUSTING Ø 7,26 TH. 2,85
6	F26603.290	1		PASTIGLIA REGOLAZ. GIOCO Ø 7,26 Sp. 2,90	SHIM, VALVE ADJUSTING Ø 7,26 TH. 2,90
6	F26603.295	1		PASTIGLIA REGOLAZ. GIOCO Ø 7,26 Sp. 2,95	SHIM, VALVE ADJUSTING Ø 7,26 TH. 2,95
6	F26603.300	1		PASTIGLIA REGOLAZ. GIOCO Ø 7,26 Sp. 3,00	SHIM, VALVE ADJUSTING Ø 7,26 TH. 3,00
6	F26603.305	1		PASTIGLIA REGOLAZ. GIOCO Ø 7,26 Sp. 3,05	SHIM, VALVE ADJUSTING Ø 7,26 TH. 3,05
6	F26603.310	1		PASTIGLIA REGOLAZ. GIOCO Ø 7,26 Sp. 3,10	SHIM, VALVE ADJUSTING Ø 7,26 TH. 3,10
6	F26603.315	1		PASTIGLIA REGOLAZ. GIOCO Ø 7,26 Sp. 3,15	SHIM, VALVE ADJUSTING 7,26 TH. 3,15
6	F26603.320	1		PASTIGLIA REGOLAZ. GIOCO Ø 7,26 Sp. 3,20	SHIM, VALVE ADJUSTING 7,26 TH. 3,20
7	F14178	8		SEMICONO D.5 - 15 ^A HAYFIELD	VALVE RETAINER D.5 15 ^A HAYFIELD
8	F26597	4		PIATTELLO SUP. MOLLA 250M3	UPPER PLATE
9	F16473	2		SET MOLLA EST. + MOLLA INT. SCAR.	EXTER. & INTER.SPRINGS EXHAUST
10	F16472	2		SET MOLLA EST. + MOLLA INT. ASP.	EXTER. & INTER.SPRINGS INLET
11	F04388	4		ANELLO TENUTA STELO VALV.D.5mm SKF	
12	F26689	4		PIATTELLO T 24X4	LOWER PLATE
13	F26728	4		GUIDA VALVOLA SINT. D.5 PER TENUTA SKF	
14	F14158	2		VALVOLA SCA 250Fi 26.8x5 TIT	EXHAUST VALVE 250Fi TIT 26.8X5
15	F14164	2		VALVOLA ASP 250Fi 32x5 TIT	INLET VALVE d.35X5 250Fi TIT



4T300FIMX22-M
MOTORE - ENGINE

TESTA
HEAD

2

Pos.	Codice	Q.tà	Note	Descrizione	Description
16	F26557	2		SEDE VALV.ASP.250cc	
17	F26558	2		SEDE VALV.SCAR.250cc	
18	F49871	2		TAPPO ASSE ROT.BILANC.250 M3	PLUG
19	F12325	2		OR ORM 090-15 FILTRO ASP.OLIO 250N	O-RING
20	F28812	1		ASSE ROTAZIONE BIL.SCAR. 250M3	AXLE, ROCKER ARM EXHAUST
21	F28811	1		ASSE ROTAZIONE BIL.ASP.250M3LO	AXLE, ROCKER ARM INTAKE
22	F28836	1		FINGER FOLLOWER WITH DECOM.MIM	FINGER FOLLOWER WITH DECOM.MIM
23	F28835	3		FINGER FOLLOWER NO DECOMP. MIM	FINGER FOLLOWER NO DECOMP. MIM
24	F28841	1		RACCORDO USCITA ACQUA TESTA	JOINT, HEAD WATER
25	F12346.1	1		O RING ORM 18,0X2,0 VITON	O-RING 18 X 2
26	F48374	2		PIASTRINO RITEGNO RACCORDO H2O	PLATE
27	49553	2		VITE TCEI 4X8	BOLT TCEI 4X8
28	F28810	1		ASSE ROTAZIONE BIL.ASP.250M3LC	AXLE, ROCKER ARM INTAKE
29	F48371	1		PIASTRINO BATT.ASSE ROT.BIL.LC	PLATE
30	49396	1		VITE TSEI 5X10	BOLT TSEI 5X10
31	F12351.1	1		O RING ORM 61,6X2,4 VITON	O-RING 61,6 X 2,4
32	F30015	1		COPERCHIO ISP. TESTA 250Fi 250 REP.4T	COVER, HEAD, TWIN
33	49481	3		VITE TCEI 6X12	BOLT TCEI 6X12
34	F49874	4		DADO M 10 X 1,25 CH 12 FLANGIATO	NUT FLANGED M 10x1,25 T.12mm
35	F48400	4		RONDELLA Ø10xØ17,5x3	WASHER Ø10xØ17,5x3
36	F21436	1		PIPETTA CANDELA RESISTIVA 250 4T MY18->	CAP, SPARK PLUG
37	F06116	1		CANDELA NGK R0451B-8	SPARK PLUG NGK R0451B-8
38	F13287	1		COLLETTORE ASPIRAZIONE 250Fi 4T REPL.	INLET MANIFOLD 250Fi F.S. R.
39	49989	3		VITE TS 5X14 TORX	BOLT TORX 5 X 14
40	F08003	1		SENSORE TEMP. ACQUA WTS 09/02	SENSOR, WATER TEMPERATURE

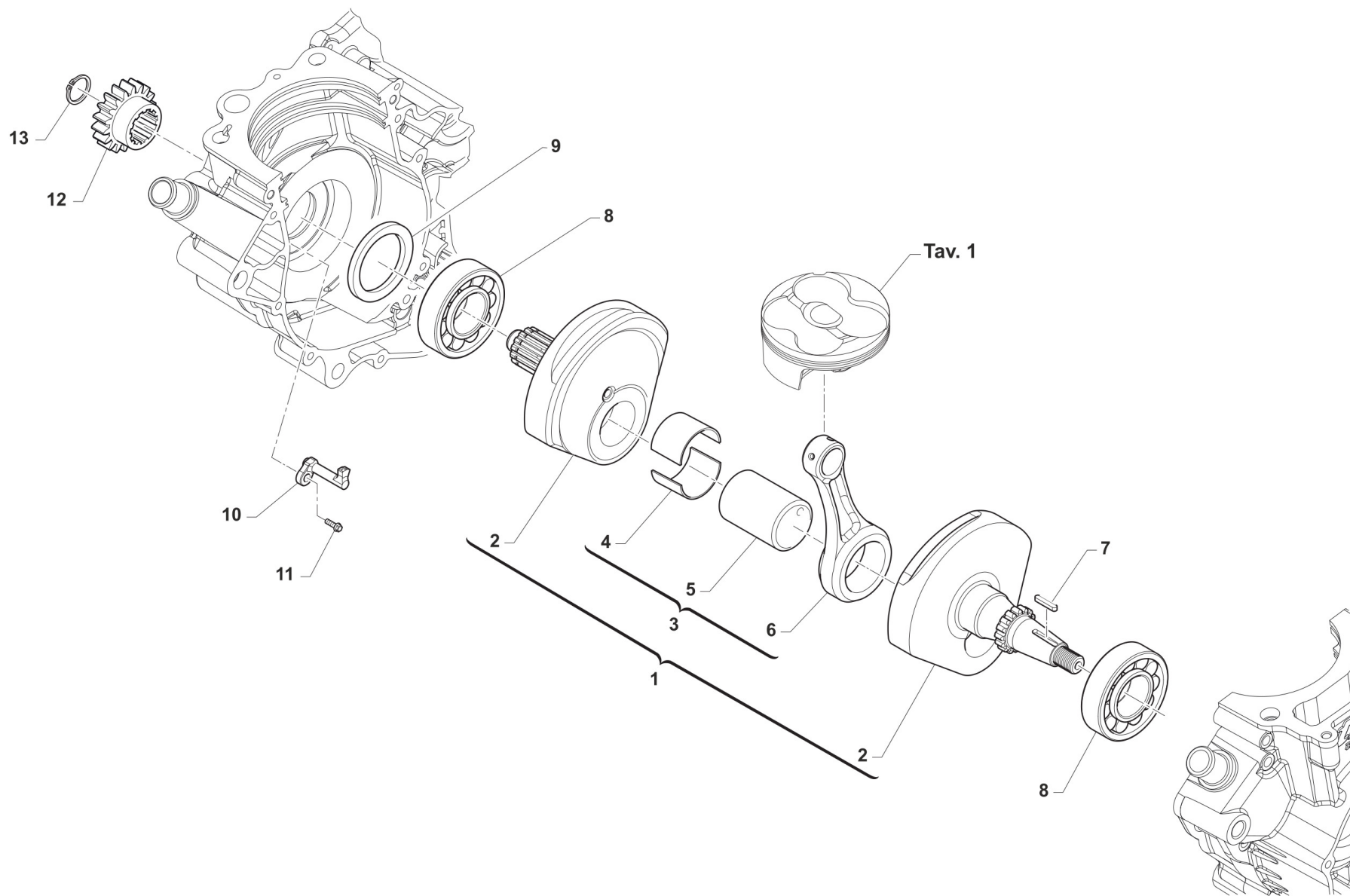



4T300FIMX22-M
MOTORE - ENGINE

MANOVELLISMO
CRANKSHAFT

3

Pos.	Codice	Q.tà	Note	Descrizione	Description
1	F18124	1		ALBERO MOTORE 300 FI K.S. 2020 CPL	
1	F18125	1		ALBERO MOTORE 300 FI E.S. 2020 CPL	
2	F18126	1		COPPIA SEMI ALBERI 300 FI K.S. 2020	
2	F18127	1		COPPIA SEMI ALBERI 300 FI E.S. 2020	
3	F18123	1		BIELLA 300FI REPLICA MX/EN CPL (D.34XD.17,8 INTERASSE 98,5)	
4	F03375.4	1		BRONZINA CP BIELLA 30X34X18 BB BLU/BLU	CONNECTING ROD BUSH ASSY 30x34x18 blu
4	F03375.5	1		BRONZINA CP BIELLA 30X34X18 RG ROSSO/GIALLO	BUSH ASSY 30x34x18 RED/YELLOW
5	F18059	1		ASSE ACCOPP. D.30X54,7 X BRONZ	
6	F18104	1		BIELLA D34XD.16 I.98,5 BR	
7	F49853	1		CHIAVETTA 5X3X25 UNI7510R.F.A.	WOODRUFF KEY, 5x3x25
8	03026	2		CUSCINETTO ALBERO MOTORE NJ206	BUSH, NJ206 CRANKSHAFT
9	F04375	1		PARAOLIO 25X35X4	
10	F32573	1		UGELLO RAFFREDDAMENTO	NOZZLE
11	49472	1		VITE TCEI 5X12 UNI 5931	BOLT TCEI 5X12
12	F40158	1		PIGNONE TRASM.PRIMARIA Z20 SCANAL.	
13	49255	1		SEEGER RETTIFICATO CAMBIO 250	CIRCLIP, GEAR BOX 250cc



4T300FIMX22-M
MOTORE - ENGINE

MANOVELLISMO
CRANKSHAFT

3

Pos.	Codice	Q.tà	Note	Descrizione	Description
1	F18125	1		ALBERO MOTORE 300 FI E.S. 2020 CPL	
2	F18127	1		COPPIA SEMI ALBERI 300 FI E.S. 2020	
3	F18123	1		BIELLA 300FI REPLICA MX/EN CPL (D.34XD.17,8 INTERASSE 98,5)	
4	F03375.4	1		BRONZINA CP BIELLA 30X34X18 BB BLU/BLU	CONNECTING ROD BUSH ASSY 30x34x18 blu
4	F03375.5	1		BRONZINA CP BIELLA 30X34X18 RG ROSSO/GIALLO	BUSH ASSY 30x34x18 RED/YELLOW
5	F18059	1		ASSE ACCOPP. D.30X54,7 X BRONZ	
6	F18104	1		BIELLA D34XD.16 I.98,5 BR	
7	F49853	1		CHIAVETTA 5X3X25 UNI7510R.F.A.	WOODRUFF KEY, 5x3x25
8	03026	2		CUSCINETTO ALBERO MOTORE NJ206	BUSH, NJ206 CRANKSHAFT
9	F04375	1		PARAOLIO 25X35X4	
10	F32573	1		UGELLO RAFFREDDAMENTO	NOZZLE
11	49472	1		VITE TCEI 5X12 UNI 5931	BOLT TCEI 5X12
12	F40158	1		PIGNONE TRASM.PRIMARIA Z20 SCANAL.	
13	49255	1		SEEGER RETTIFICATO CAMBIO 250	CIRCLIP, GEAR BOX 250cc

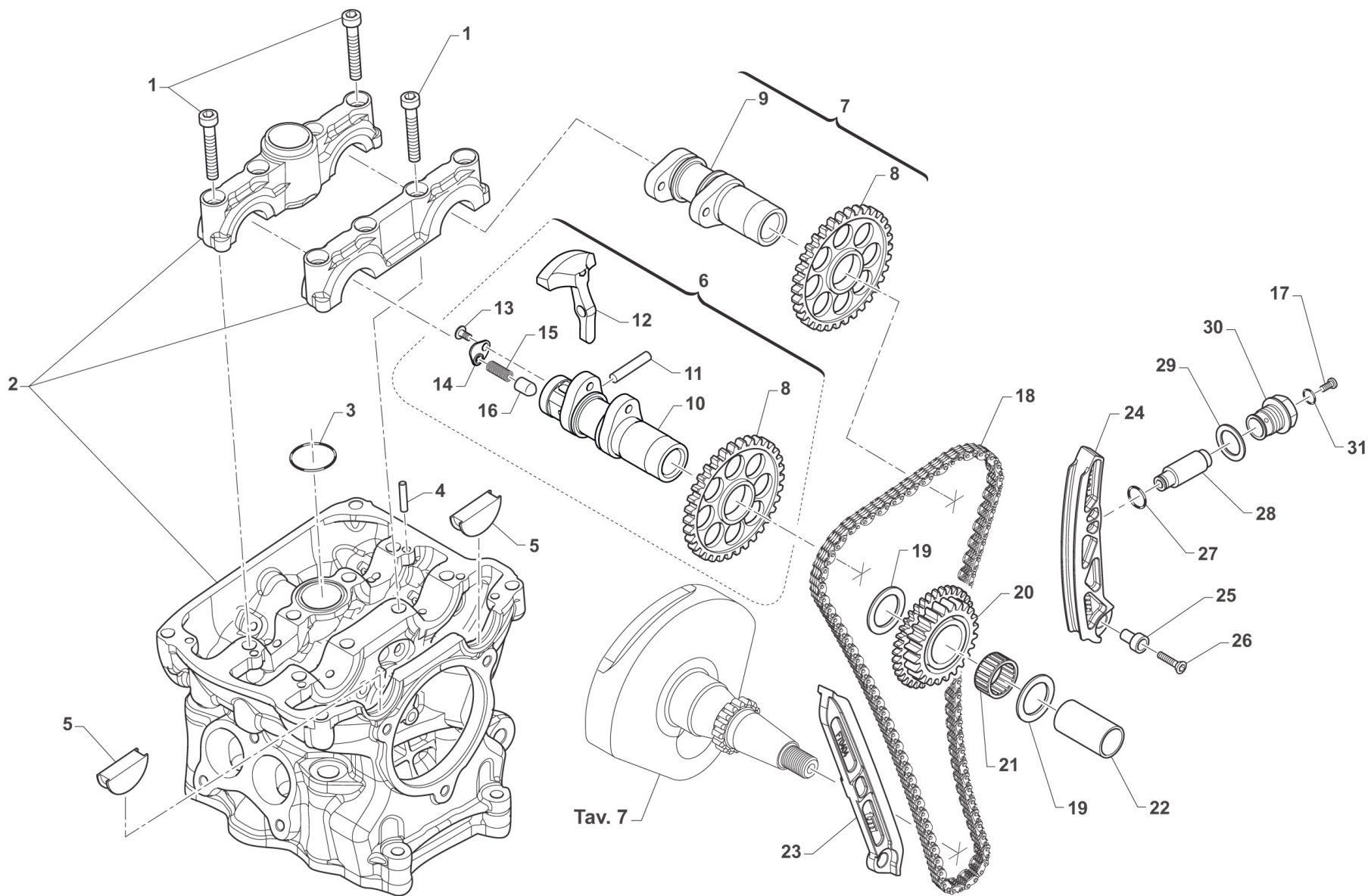

TM0004



4T300FIMX22-M
MOTORE - ENGINE

DISTRIBUZIONE
VALVES COVER

4

Pos.	Codice	Q.tà	Note	Descrizione	Description
1	49487	8		VITE TCEI 6X35 UNI 5931	BOLT TCEI 6X35
2	F02887	1		TESTA 250Fi MX CPL M 18->	CYLINDER HEAD 250Fi F.S. MX M18->
3	F12344.1	1		O RING ORM 23,0X1,5 VITON	O-RING 23 X 1,5
4	F19529	4		RULLO D.4 X 10 TESTA BOMBATA" NRA"	PIN 4 X 10
5	F30060	2		COPERC.TTO FORI A.CAMME250/300	CAP, HOLE CAMSHAFT 250/300
6	F28852	1		ALBERO A CAMME SCARICO 250Fi MX ES + EN CPL	CAMSHAFT ASSY, EX, 250 MX ES + EN
7	F28846	1		ALBERO A CAMME ASPIRAZIONE 250Fi MX 2018 CPL	
8	F40062	2		INGR. ALBERO A CAMME GEN. Z28	GEAR 28T, CAMSHAFT
9	F28807	1		ALBERO A CAMME ASP. EVO3 XA-18	
10	F28809	1		ALBERO A CAMME SCAR.EVO3 XS-04	CAMSHAFT EX XS-04
11	F19530	1		RULLO D.5 X 19.8 G2 0 -0.010	PIN 5 X 19,8
12	F26575	1		DECOMPRESSORE (MASSA CENT.) M3	DECOMPRESSOR
13	49597	1		VITE TBCEI 4 x 8 UNI 7380	BOLT TBCE 4 x 8
14	F48368	1		PIASTRINO GUIDA MOLLA DECOMPR.	PLATE DECOMPRESSOR SPRING 250 F.S.
15	F16479	1		MOLLA AZIONAMENTO DECOMP. D.0,3 250 4T REP.	SPRING
16	F26576	1		PISTONCINO ATTIVAZIONE DECOMP.	PISTON DECOMPRESSOR
17	F49871	1		TAPPO ASSE ROT.BILANC.250 M3	PLUG
18	F70423	1		CATENA DIST.MORSE 92RH2015 92P 300 TWIN	CAM CHAIN 92RH2015 92 300 TWIN
19	F48372	2		RASAMENTO 18 x 30 x 0.8	SHIM 18 X 30 X 0,8
20	F40061	1		INGR. DOPPIO DISTRIBUZ.24/21	GEAR 24/21T DISTRIBUTION
21	F19526	1		GABBIA A RULLINI K 18X22X17	NEEDLE BUSH 18x22x17
22	F28813	1		ASSE ROTAZIONE INTR.18X42,7F13	PIN ROTATION GEAR 18x42,7 H.13
23	F70404	1		PATTINO FISSO 4T 250/300 TWIN	FIXED SLIDER
24	F70413	1		PATTINO MOBILE 4T 250/300 TWIN	MOVING SLIDER
25	F49883	2		BOCCOLA FISS. PATT.MOB. F70402	BUSH
26	49406	1		VITE TSEI 6X20	BOLT TSEI 6x20
27	F12346.1	1		O RING ORM 18,0X2,0 VITON	O-RING 18 X 2



4T300FIMX22-M
MOTORE - ENGINE

DISTRIBUZIONE
VALVES COVER

4

Pos.	Codice	Q.tà	Note	Descrizione	Description
28	F70408	1		TENDITORE IDRAULICO 250 M3 F-346264.89-0100.KSH.KSYS	HYDRAULIC TENSIONER 250Fi M3
29	49949	1		RONDELLA RAME 24X30X1,5	WASHER, COPPER, 24 X 30 X 1,5
30	F49884	1		TAPPO TENSIONATORE IDR. M3	PLUG, TENSIONER
31	F12356.1	1		O RING ORM 10,0X1,0 VITON	O-RING 10 X 1

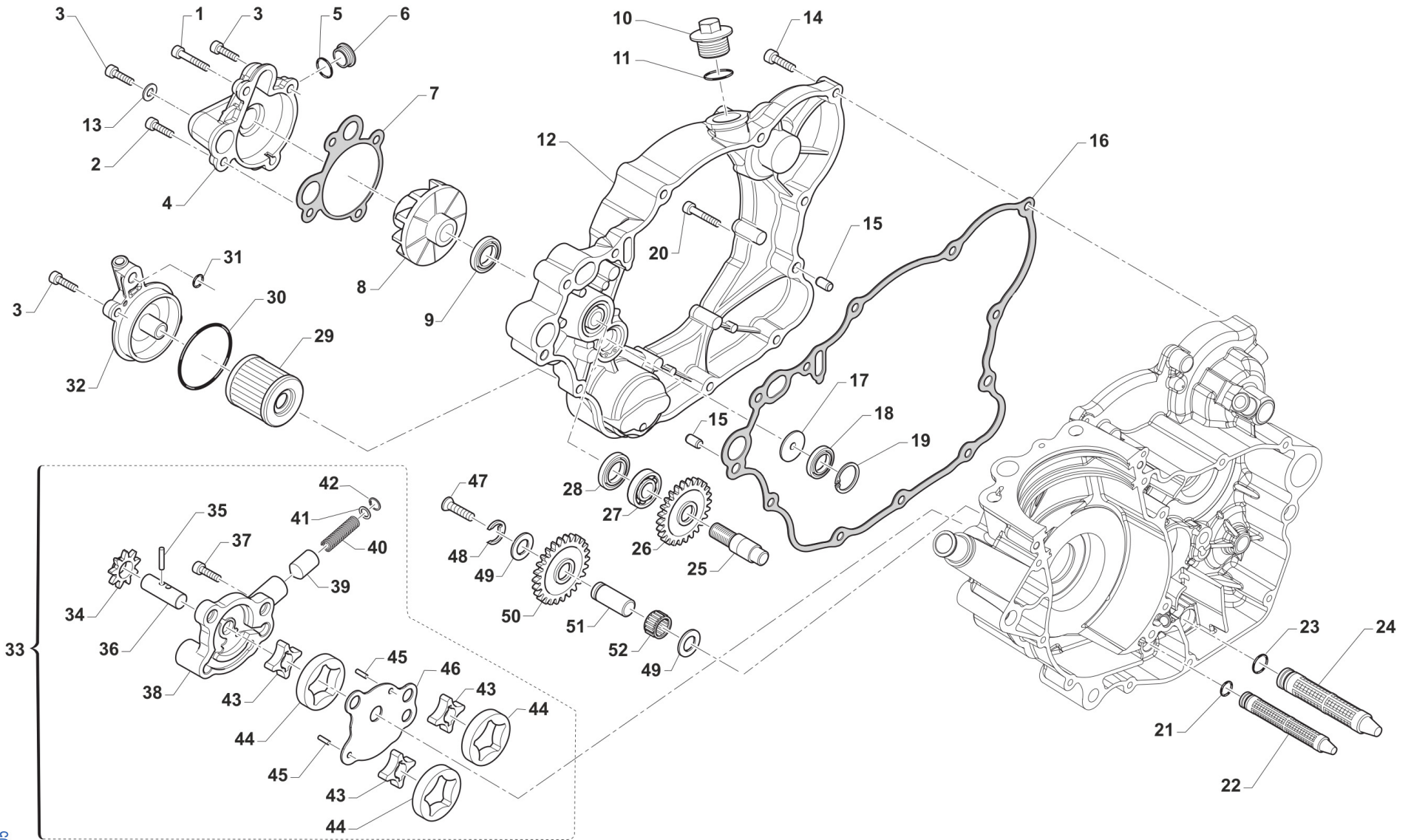

TM0005



4T300FIMX22-M
MOTORE - ENGINE

LUBRIFICAZIONE
LUBRIFICATION

5

Pos.	Codice	Q.tà	Note	Descrizione	Description
1	49575	1		VITE TCEI 5X45 UNI 5931	BOLT TCEI 5X45
2	49570	1		VITE TCEI 5X50 UNI 5931	SCREW TCEI 5X50
3	49476	3		VITE TCEI 5X20 UNI 5931	BOLT TCEI 5X20
4	F30966	1		COPERCHIO POMPA H2O 250Fi 11/-	COVER, WATER PUMP 250Fi M.2011
5	F12327	1		O RING COPERCHIO P.ACQUA 250N	O-RING COVER WATER PUMP 250 4S
6	F49841	1		TAPPO COP. POMPA H2O 250Fi	CAP, COVER WATER PUMP 250 4S
7	F05833	1		GUARNIZ.COP.POMPA ACQUA.250N	GASKET, H2O COVER 250Fi
8	F28679	1		GIRANTE POMPA ACQUA 250N	IMPELLER, H2O PUMP 250Fi
9	04017	1		PARAOLIO CENTRIFUGA 06 +MF1TAG	OIL SEAL 8 X 22 X 7 TC
10	F49925	1		TAPPO CARICO OLIO M20X1.5	OIL PLUG M20X1,5
11	F49920	1		RONDELLA ALL 20.4X26X1.5	WASHER 20,4X26X1,5 ALUM.
12	F30961	1		COPERCHIO TRAS. PRIM. 250N '11	COVER, PRIMARY DRIVE 250N 11->
13	49119	1		RONDELLA 5 x 9 x 1,5 ALLUMINIO	WASHER, 5 x 9 x 1.5 ALLUMINIUM
14	49477	7		VITE TCEI 5X25 UNI 5931	BOLT TCEI 5X25
15	26041	2		GRANO CENTRAGGIO D.7X8 F.5,2	DOWEL PIN 7 x 8 Hole 5,2
16	F05828	1		GUARNIZ.COP.TRASM.PRIMAR.250N	GASKET, CLUTCH CASE 250Fi
17	F32529	1		DISCHETTO PARZIAL. MAND.OLIO 250N	DISC OIL PUMP 250 F.S.
18	F04390	1		PARAOLIO FAJ 14-22-5 HS	OIL SEAL FAJ 14-22-5 HS
19	F49913	1		SEEGER I 23	CIRCLIP INT. 23
20	49478	1		VITE TCEI 5X30 UNI 5931	BOLT TCEI 5X30
21	F12325	1		OR ORM 090-15 FILTRO ASP.OLIO 250N	O-RING
22	F32532	1		FILTRO ASPIRAZ.POMPE OLIO 250N	FILTER, OIL, 250Fi
23	F12343	1		O RING FILTRO OLIO 250F	O-RING
24	F32555	1		FILTRO ASPIRAZIONE OLIO MAGG.	FILTER OIL INLET
25	F28658	1		ALBERINO POMPA H2O 250N	SHAFT, WATER PUMP 250Fi
26	F40112	1		INGRANAGGIO COND.P.ACQUA 3004T	
27	F03365	1		CUSCINETTO POMPA ACQUA 250/09	BEARING WATER PUMP 250/09
28	F04363	1		PARAOLIO 8X22X5 250/09->	OIL SEAL 8x22x5 (250F/09)



4T300FIMX22-M
MOTORE - ENGINE

LUBRIFICAZIONE
LUBRIFICATION

5

Pos.	Codice	Q.tà	Note	Descrizione	Description
29	F66510	1		FILTRO OLIO 4Tempi HF 141	OIL FILTER HF - 141
30	12094	1		O RING COP. FILTRO OLIO	O RING OIL FILTER COVER
31	F12302	1		O RING 108 PIOGGIA CAMBIO 4T	O-RING, 108 GEAR F.S.
32	F30965	1		COPERCHIO FILTRO OLIO 250Fi 11	CAP, OIL FILTER 250Fi 11->
33	F30068	1		POMPA OLIO COMPLETA 250/300 Fi TWIN	OIL PUMP ASSY
34	F40997	1		INGRANAGGIO POMPA OLIO 250Fi Z 9	GEAR, OIL PUMP 250Fi 9 T
35	F19513	3		RULLINO ING. POMPA 250/09	PIN, PUMP GEAR 250 09->
36	F28840	1		ALBERINO POM.OLIO RO.H10/2XH10	SHAFT, OIL PUMP
37	49751	2		VITE TCEI 5X22	BOLT TCEI 5 X 22
38	F30059	1		CORPO POMPA	OIL PUMP BODY
39	F32533	1		PIST.NE VALV.LIMIT.PRESS.OLIO	PISTON
40	F16441	1		MOLLA VALVOLA PRESS.OLIO 250N	SPRING
41	49600	1		RONDELLA 4x8x0,8	WASHER 4
42	49267	1		SEEGER 8mm INT Sp. 0,8	SEEGER
43	F32577	3		ROTORE INTERNO POMPA OLIO 250Fi	ROTOR, OIL PUMP, INTERNAL
44	F32578	3		ROTORE ESTERNO POMPA OLIO 250Fi	ROTOR, OIL PUMP, EXTERNAL
45	F19521	2		RULLINO D.3 X 11	PIN 3 X 11
46	F32574	1		SEPARATORE POMPA OLIO	PLATE
47	49429	1		VITE TSEI 4X35	BOLT TSEI 4X35
48	F49821	1		SEEGER ING.FOLLE P.OL. 250/09	SEEGER INTER.GEAR OIL P.250 4S
49	F19512	2		RALLA ING.FOLLE P. OLIO 250/09	THRUST WASHER
50	F40909	1		INGR. OZIOSO POMPA OLIO 250N	GEAR, OIL PUMP
51	F28665	1		ALBERINO ING.FOLLE P.OLIO 250N	SHAFT
52	F19511	1		GABBIA RULLI ING.F.P.OL.250/09	NEEDLE CAGE GEAR 250F 09->

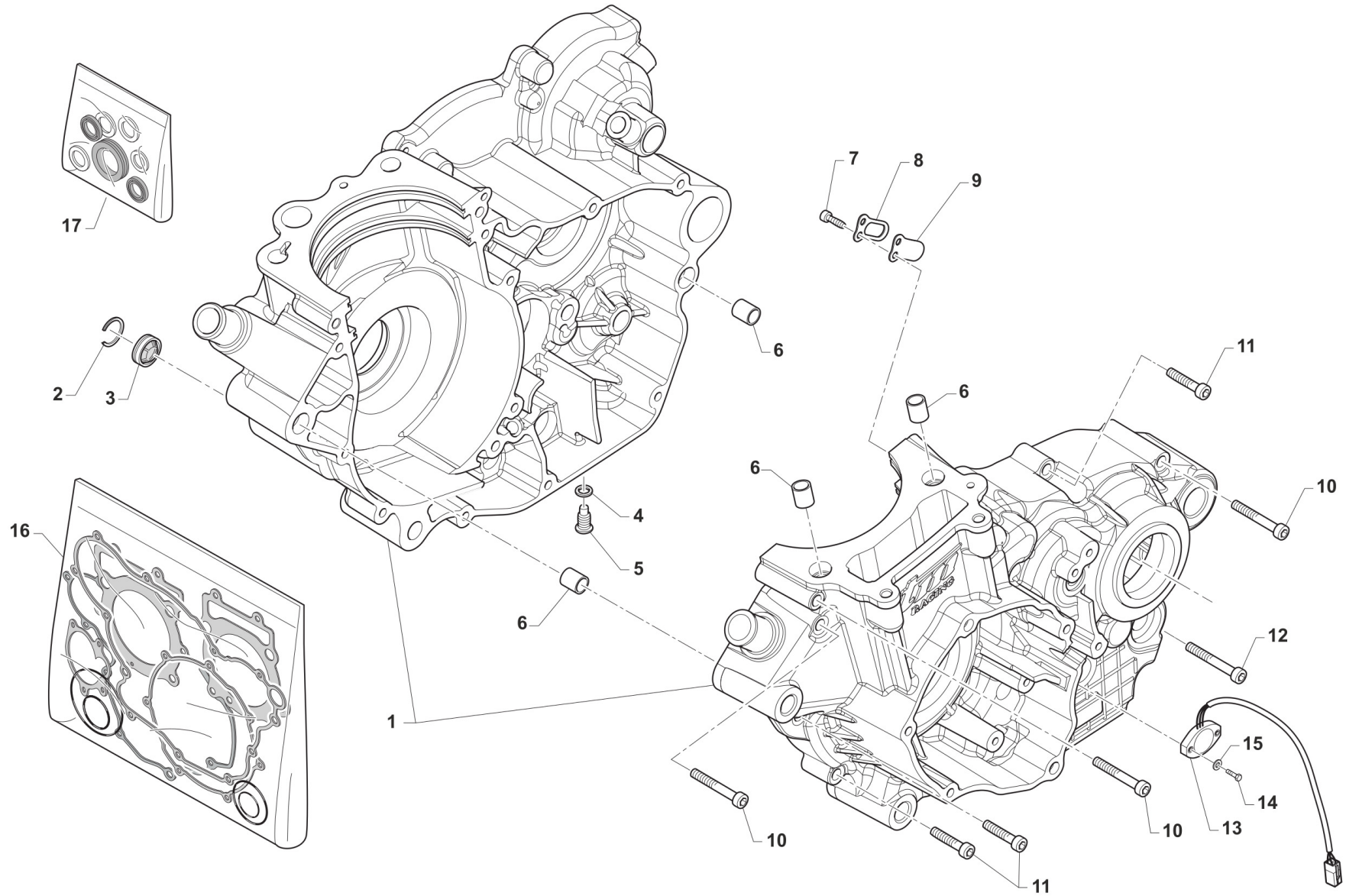

TM0006



4T300FIMX22-M
MOTORE - ENGINE

CARTER MOTORE
CLUTCH CASE

6

Pos.	Codice	Q.tà	Note	Descrizione	Description
1	F30076	1		BASAMENTO MOT. 300Fi ES TWIN 20	
2	F49832	1		SEEGER SB25 OBLO' 250Fi 10/->	SEEGER
3	F04366	1		OBLO' LIVELLO OLIO DIAM.25 MM	OIL LEVEL INSPECTION SIGHT GLASS
4	49125	2		RONDELLA 12X18X1,5 ALLUMINIO	WASHER 12X18X1,5 AI
5	F49820.1	2		TAPPO OLIO C/CALAM. 250Fi	OIL PLUG WITH MAGNET 250Fi
6	F26428	4		GRANO RIFERIMENTO 12X13 F10.2	GRUB SCREW 12X13 H.10,2mm
7	49542	1		VITE TCEI 5X10 UNI 5931	BOLT TCEI 5 X 10
8	F20004	1		STOPPER LAMELL.CAMERA ALB.250N	STOPPER, STOP
9	F20003	1		LAMELLA SFIATO PRESS.250Fi	REED
10	49491	3		VITE TCEI 6X55	BOLT TCEI 6X55
11	49487	4		VITE TCEI 6X35 UNI 5931	BOLT TCEI 6X35
12	49492	1		VITE TCEI 6X60	BOLT TCEI 6X60
13	F08456	1		SENSORE POSIZIONE CAMBIO eM060 CPL G.ORARIO (SOSTITUISCE F08236.1)	
14	49904	2		VITE TSEI 3X8	BOLT TSEI 3 X 8
15	49926	2		RONDELLA 3X9X1	WASHER 3 X 9 X 1
16	F05864	1		KIT GUARNIZIONI 300Fi EN/MX MY20 REPLICA	GASKETS 300FI EN7MX MY20->
17	04043	1		KIT PARAOLI 4T 250/300Fi TWIN MY2022	

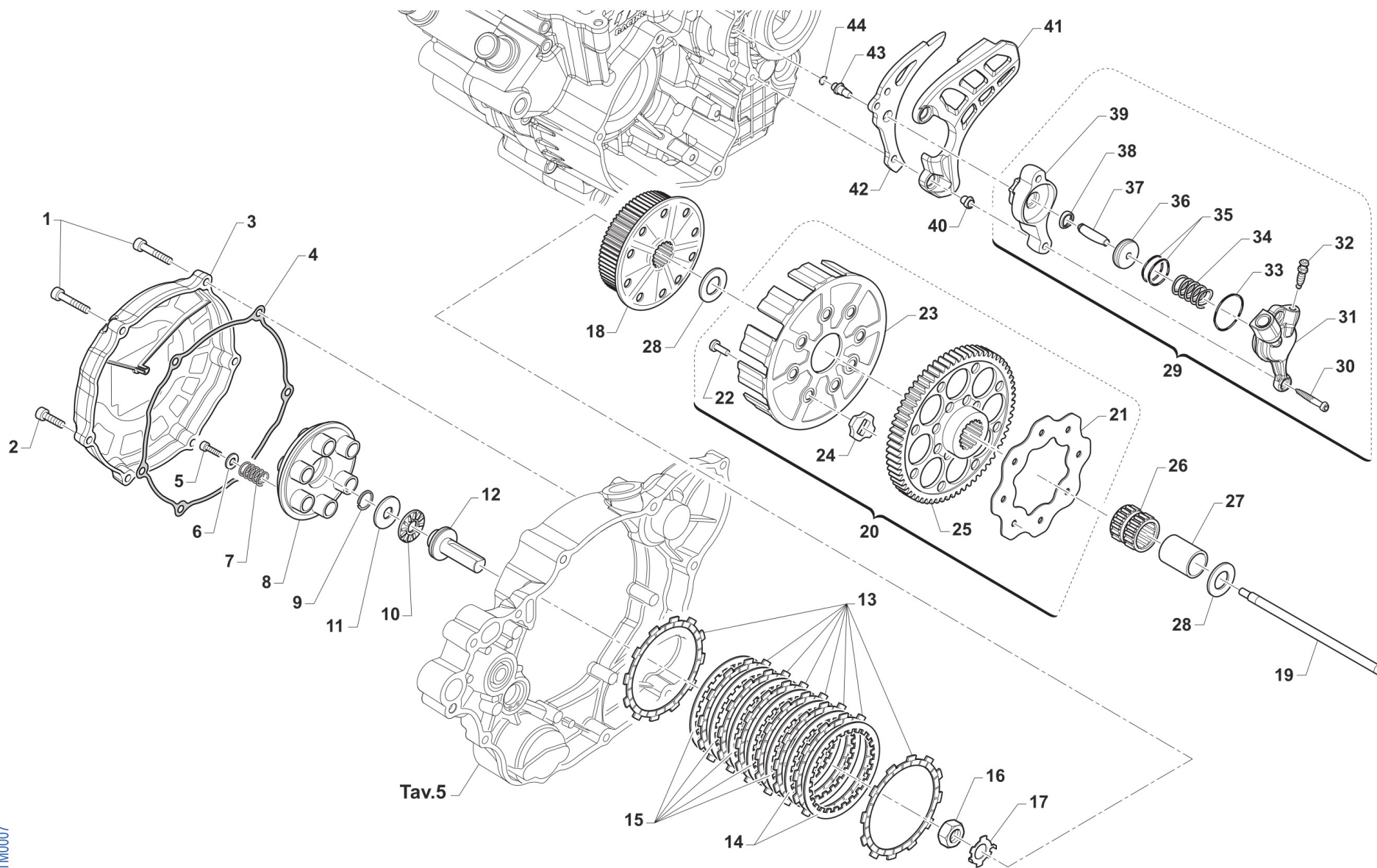



4T300FIMX22-M
MOTORE - ENGINE

FRIZIONE
CLUTCH

Pos.	Codice	Q.tà	Note	Descrizione	Description
1	49736	2		VITE TCEI 5X65	BOLT TCEI 5X65
2	49477	4		VITE TCEI 5X25 UNI 5931	BOLT TCEI 5X25
3	F30960	1		COPERCHIETTO FRIZ.250Fi M.11->	COVER, CLUTCH 250Fi M. 11/->
4	F05841	1		GUARN. COP. FRIZ. 250Fi 2011	GASKET, CLUTCH COV 250Fi 11/->
5	49484	6		VITE TCEI 6X20	BOLT TCEI 6X20
6	49604	6		RONDELLA 6 X18 X 1,6	WASHER 6x18
7	F16453	6		MOLLA FRIZIONE 2/4T 250/450	SPRING, CLUTCH 2/4T 250/450
8	F25258	1		PIATTO SPINGIDISCHI 250Fi	PRESSURE PLATE, CLUTCH 250Fi
9	09006	1		ANELLINO FERMA SPINOTTO 80/85/100	CLIP, PISTON PIN 80/85/100cc
10	19022	1		GABBIA A RULLI RAD. AXK 1528	BUSH CAGE AXK 1528, RADIAL
11	19023	1		RONDELLA GABBIA RULLI AS 1528	WASHER, NEEDLE CAGE AS 1528
12	F35582	1		FUNGO FRIZIONE IDRAULICA 2015	PIECE, CLUTCH LIFTER
13	F35588	8		DISCO FRIZIONE 250Fi 4T FCC	CLUTCH PLATE, FIBER 250Fi 4S
14	F35596	2		DISCO FRIZ. ACC 1,8 mm 250Fi	CLUTCH DISC STEEL 1,8 mm 250Fi
15	F35541	5		DISCO FRIZ. ACC 1,5 mm 250N	CLUTCH PLATE, STEEL 1,5 250Fi
16	49060	1		DADO TAMBUR.FRIZ. ALB.PRIM. 250/300 M18X1.5	NUT, CLUTCH CENTER 250cc
17	35050	1		RONDELLA X FRIZ. 250/300/4T	CLUTCH WASHER 250/300/F
18	F25256	1		TAMBURELLO FRIZ.250F -N-	CLUTCH CENTER 250Fi
19	F35544	1		ASTINA CENTRAL.FRIZ.192mm 250N	ROD, CLUTCH 192mm 250N
20	F40159	1		COPPIA PRIMARIA CPL 300Fi Z 59/18	
21	35262	1		DISCO BATTUTA GOMMINI FRIZ. 2T/4T F.6 MM	PLATE, CLUTCH BASKET 250cc
22	49202	8		CHiodo FRIZIONE K3/KV/K7 D 5,8	PIN CLUTCH K3/KV/K7/K8/K9
23	F25257	1		CAMPANA FRIZ. 250Fi	CLUTCH BASKET 250Fi M. 10/->
24	21005	8		GOMMINO PARASTRAPPI FRIZIONE	RUBBER, CLUTCH BASKET
25	F40114	1		CORONA TRAS.PRIMARIA Z59 3004T	
26	F19510	1		GABBIA A RULLINI K 27X32X23.8	NEEDLE CAGE 27 x 32 x 23.8
27	F26422	1		BOCCOLA INGR.TRASM.PRIM. 250N	BUSH, PRIMARY GEAR 250Fi
28	48250	2		SPESSORE COPPIA PRIMARIA 250	SPACER, PRIMARY GEAR 250cc



4T300FIMX22-M
MOTORE - ENGINE

FRIZIONE
CLUTCH

Pos.	Codice	Q.tà	Note	Descrizione	Description
29	F30005	1		COP. FRIZ/IDR 4T 250N D.26 CPL	COVER, IDR/CLUTCH 4S 250N ASSY
30	49535	2		VITE TCEI 5X35 UNI 5931	BOLT TCEI 5X35
31	F30006	1		CORPO CILIN. FRIZ. 250Fi D.26	BODY CLUTCH CYLINDER 250Fi D26
32	35264	1		VITE SPURGO OLIO FRIZ.IDR.6X1	SCREW AIR BLEED HYDRAUL.CLUTCH
33	12252	1		O RING PIGNONE CAT.+DIS.AL.MOT	O-RING, 25,12 x 1,78
34	F16445	1		MOLLA PIST. FRIZ. 250N CONICA	SPRING
35	12259	2		O RING PISTONE FR.125/250VERDE	O-RING, CLUTCH PISTON 125/250
36	F35522	1		PISTONE CILINDRETTO 250N D.26	PISTON CLUTCH CYLINDER 250F 26
37	F19518	1		RULLO D.S. 5 X 24	PIN 5 X 24
38	F04367	1		PARAOLIO 9X13X3	OIL SEAL 9X13X3
39	F35523	1		DISTANZIALE CILINDRETTO 250N	SPACER CYLINDER 250N
40	26211	2		BOCCOLA PROT. PIGNONE 250 F.5	COLLAR, SPROCKET 250cc H.5
41	F30944	1		PROTEZIONE PIGNONE 250Fi PLAST	SPROCKET PROTECTION 250 F.I. PLAST.
42	F70370	1		PROTEZ. ERGAL PIGN. CAT 250N	PROTECTION, ALUMINIUM, FRONT SPROCKET
43	F26460	1		DIST.CENTR.SUPP.ATT.FRIZ.250N	SPACER
44	F12302	1		O RING 108 PIOGGIA CAMBIO 4T	O-RING, 108 GEAR F.S.

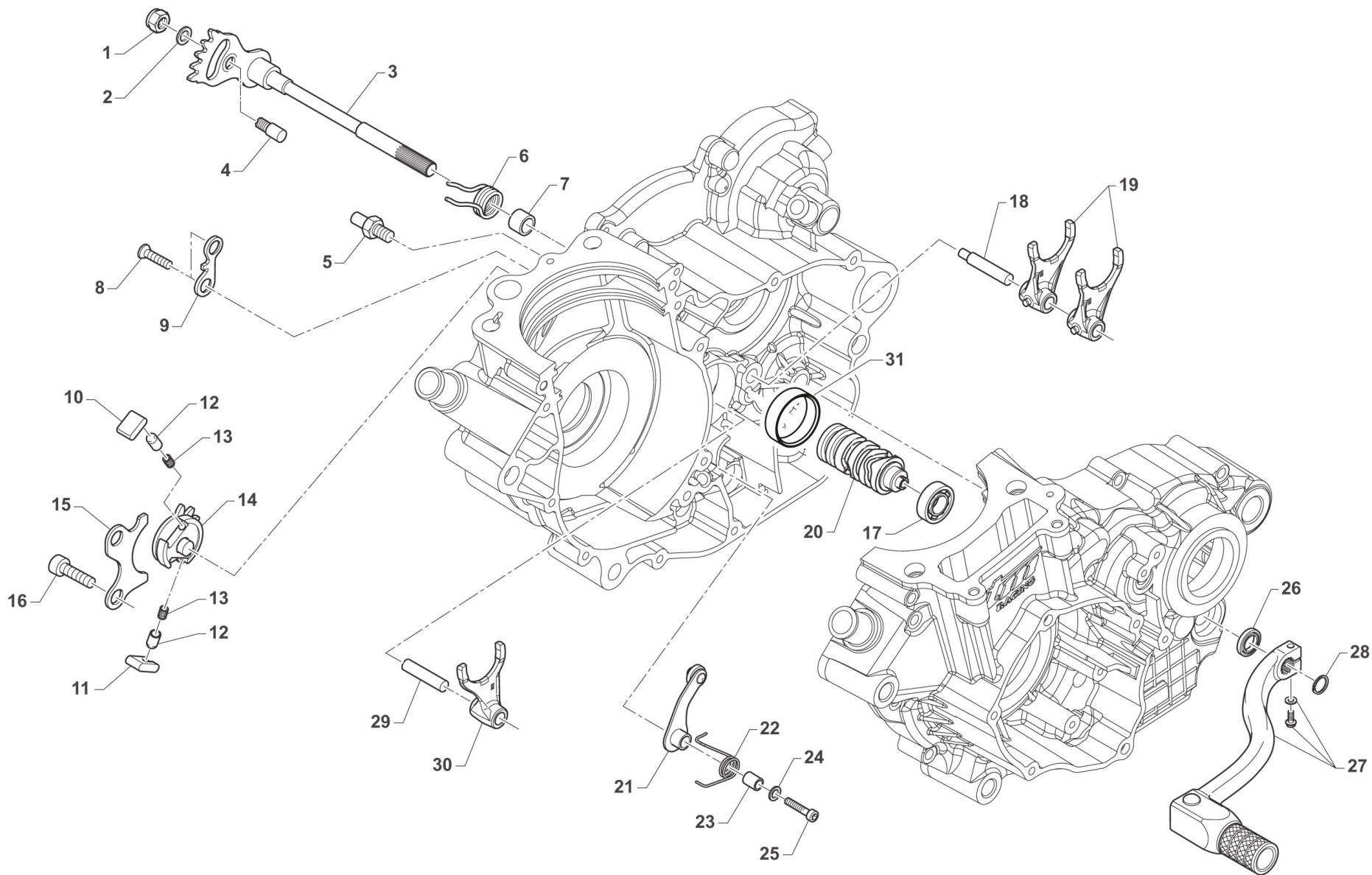



4T300FIMX22-M
MOTORE - ENGINE

COMANDO CAMBIO
GEARSHIFT MECHANISM

8

Pos.	Codice	Q.tà	Note	Descrizione	Description
1	49638	1		DADO M 6 ALTO AUTOBLOCCANTE	NUT 6mm, HIGHT SELF-LOCKING
2	49603	1		RONDELLA M 6,4 X 12 X 1,6	WASHER 6x12
3	28100	1		ALBERO COMANDO ING. P.TACRIC.	SHAFT, GEARSHIFT
4	26050	1		BATTUTA ECCENTRICA	ADJUSTER SELECTOR SHAFT
5	F26455	1		BATTUTA FISSA MAN.CAMBIO 250N	
6	16010	1		MOLLA RITORNO LEVA CAMBIO 3	SPRING, RETURN GEAR LEVER 3mm
7	26006	1		DISTANZIALE MOLLA LEVA CAMBIO	SPACER, GEAR LEVER SPRING
8	49405	2		VITE TSEI 6X20 UMB.5933 10.9	BOLT TSEI 6x20 U.5933 10.9
9	F26454	1		PIASTR.FINECORSO CRIC. 250N	PLATE, ENDSTROKE RATCHET 250N
10	26060	1		CRICCHETTO CAMBIO SUPERIORE	RATCHET UP, GEAR
11	26061	1		CRICCHETTO CAMBIO INFERIORE	RATCHET DOWN, GEAR
12	26062	2		PUNTALE PER CRICCHETTO CAMBIO	PIN, RATCHET GEAR
13	16012	2		MOLLA PER PUNTALE	SPRING, GEARBOX PIN
14	40310	1		INGRANAGGIO PORTACRICCHETTI	DRUM SHIFTER GEAR
15	26021	1		PIASTRINO RIENTRO CRICCHETTI	PLATE, RATCHET
16	49483	2		VITE TCEI 6X16 UNI 5931	BOLT TCEI 6X16
17	03012	1		CUSCINETTO DESMODROMICO 6001 2RS	BUSH, 6001 2RS GEAR DRUM
18	33256	1		PERNO FORCH.ALB.SEC. 250 / 125.99	AXEL, COUNTERSHAFT FORK 250cc
19	F33312.1	2		FORCHETTA A/S 300Fi CROMATA	FORK SHIFT COUNTERS.300FiCHROM
20	F33329	1		ALBERO DESMO 6M 250N INT.P.CPL CPL DI F26476 + MAGNETE	CAM, GEAR SHIFT
21	F26479	1		PIASTRINO BLOCCA MAR. 250Fi 12	PLATE, STOP GEAR 250 4S 12->
22	F16447	1		NON UTILIZZARE !!! MOLLA BLOCCA MARCE 250Nsostituita da F16447.3	SPRING, STOP GEAR 250 4S
23	26007	1		DISTANZIALE MOLLA BLOCCAMARCE	SPACER, STOP GEAR SPRING
24	49604	1		RONDELLA 6 X18 X 1,6	WASHER 6x18
25	49485	1		VITE TCEI 6X25 UNI 5931	BOLT TCEI 6x25
26	04004	1		PARAOLIO POMPA H2O-LEVA CAMBIO	OIL SEAL 12 x 22 x 5



4T300FIMX22-M
MOTORE - ENGINE

COMANDO CAMBIO
GEARSHIFT MECHANISM

8

Pos.	Codice	Q.tà	Note	Descrizione	Description
27	43048	1		LEVA CAMBIO 2014 + 12MM (253) 85/125/144 2T 250Fi	GEAR LEVER 2014 +12mm
28	49212	1		SEEGER E12 LEVA CAMBIO	CIRCLIP D.12 - EXTERNAL
29	33255	1		PERNO FORCH.ALB. PRIM.250 / 125.99	AXEL, MAINSHAFT FORK 250cc
30	F33311.1	1		FORCHETTA A/P 300Fi CROMATA	SHIFT FORK MAINSH.300Fi CHROME
31	19041	1		ASTUCCIO A RULLI DHK 35/12	BUSH NEEDLE CAGE DHK 35/12

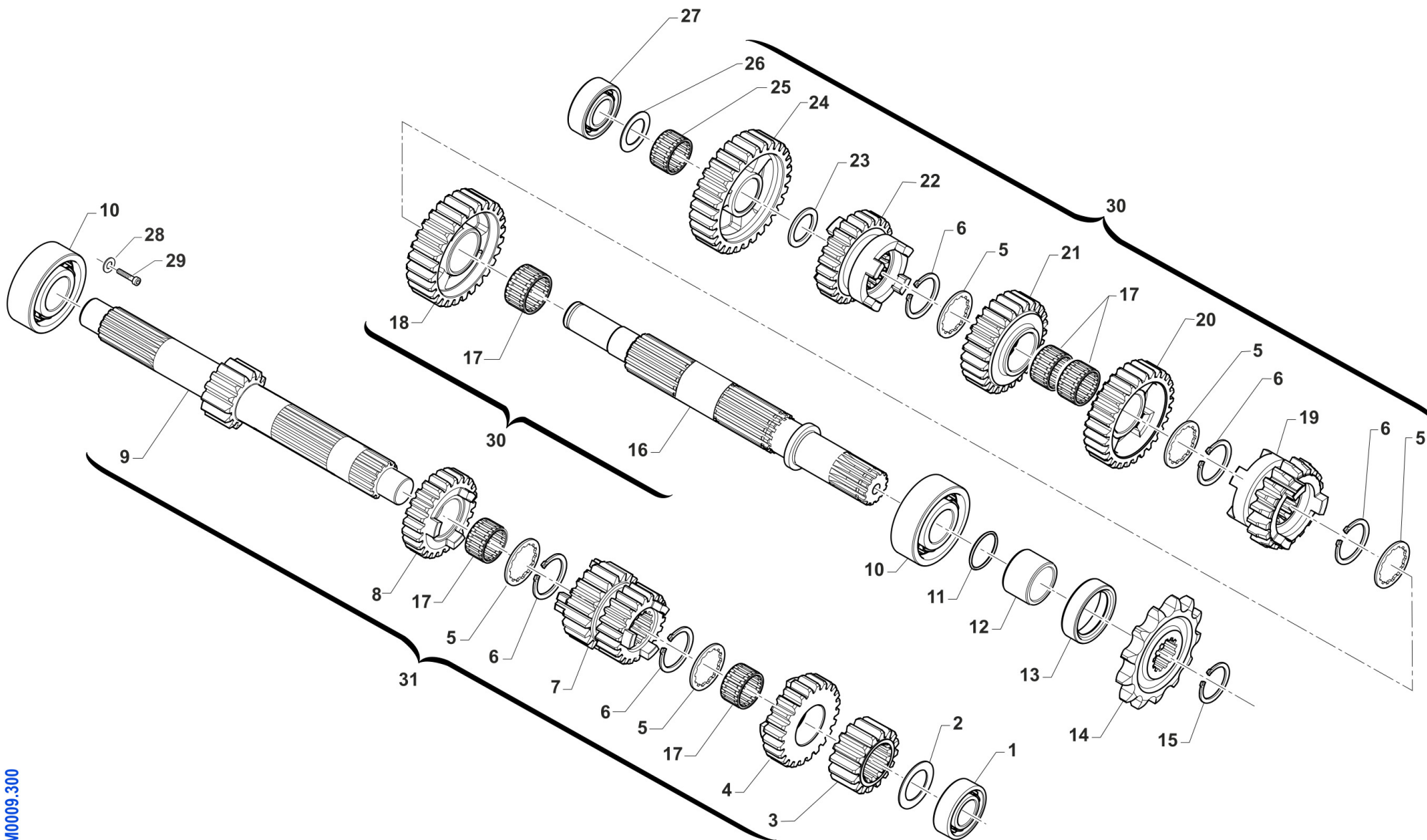

TM0009.300



4T300FIMX22-M
MOTORE - ENGINE

CAMBIO 6 MARCE
6 GEARS GEARBOX

Pos.	Codice	Q.tà	Note	Descrizione	Description
1	03254	1		CUSCINETTO A.P.4 Tempi 2RS1/C3	BUSH, MAINSHAFT 2RS/C3 4S
2	48253	1		SPESSORE CAMBIO 17X30X1 250	SPACER, GEAR BOX 250cc 17X30X1
3	F40102	1		INGRANAGGIO 2a A.P. Z15 300 4T	
4	F40105	1		INGRANAGGIO 6a A.P. Z22 300 4T	GEAR, 6th 22T MAINSHAFT 300Fi
5	F40036.1	5		RALLA BROCCIATA DIN 5480 TRANC	WASHER GEAR DIN 5480
6	F49869	5		SEEGER SW 24 (EST.) "SEEGER"	CIRCLIP SW 24 (EXTERNAL)
7	F40103	1		INGRANAGGIO 3/4aA.P.Z16/20 300	GEAR,3/4th 16/20T MAINSH.300Fi
8	F40104	1		INGRANAGGIO 5a A.P. Z20 300 4T	GEAR, 5th 20T MAINSHAFT 300Fi
9	F40101	1		ALBERO PRIMARIO Z 13 300 4T	
10	F03368	2		CUSCINETTO 62/22 C3 22x50x14	BUSH, 62/22 C3 22x50x14
11	F12320	1		O RING BOCCOLA PIGNONE 250/09	O-RING NBR 2087
12	F26421	1		DISTANZ. PIGNONE CATENA 250N	SPACER SPROCKET CHAIN 250N
13	04113	1		PARAOLIO 28X38X7 125TAG	OIL SEAL 28 x 38 x 7
14	F40889	1		PIGNONE CATENA 250N - Z13	SPROCKET 13T, DRIVE 250Fi
14	F40933	1		PIGNONE CATENA 250N - Z14	SPROCKET 14T, DRIVE 250Fi
14	F40956	1		PIGNONE CATENA 250N - Z12	SPROCKET 12T, DRIVE 250Fi
15	49217	1		SEEGER E22 ANELLO ALB/S	CIRCLIP D.22 - COUNTERSHAFT
16	F40899.1	1		ALBERO SECONDARIO MX/E 300Fi 4T	
17	F19524	5		GABBIA A RULLI 22X26X10 TAGL.	NEEDLE BEARING 22 X 26 X 10
18	F40107	1		INGRANAGGIO 2a A.S. Z27 300 4T	
19	F40111	1		INGRANAGGIO 6a A.S. Z20 300 4T	GEAR, 6th 20T COUNTERSHAFT 300Fi
20	F40108	1		INGRANAGGIO 3a A.S. Z23 300 4T	GEAR, 3th 23T COUNTERSHA.300Fi
21	F40109	1		INGRANAGGIO 4a A.S. Z24 300 4T	GEAR, 4th 24T COUNTERSHA.300Fi
22	F40110	1		INGRANAGGIO 5a A.S. Z21 300 4T	GEAR 5th COUNTERSH. Z21 300 4S
23	F48353	1		SPESSORE PS 18X25X1	SPACER
24	F40106	1		INGRANAGGIO 1a A.S. Z31 300 4T	GEAR, 1st 31T COUNTERSH. 300Fi
25	F19514	1		GABBIA A RULLI 18X22X10	NEEDLE CAGE 18X22X10
26	48012	1		RASAMENTO A/S M/M SPESS.0,5	SPACER, 26x17x0,5



4T300FIMX22-M
MOTORE - ENGINE

CAMBIO 6 MARCE
6 GEARS GEARBOX

Pos.	Codice	Q.tà	Note	Descrizione	Description
27	F03367	1		CUSCINETTO 6003 TN9C3 17x35x10	BUSH, 6003 TN9 C3 17x35x10
28	49603	1		RONDELLA M 6,4 X 12 X 1,6	WASHER 6x12
29	49480	1		VITE TCEI 6X10 UNI 5931	BOLT TCEI 6X10
30	F40161	1		ALBERO SECONDARIO 300Fi 4T 6M CPL	
31	F40160	1		ALBERO PRIMARIO 300Fi 4T 6M CPL	

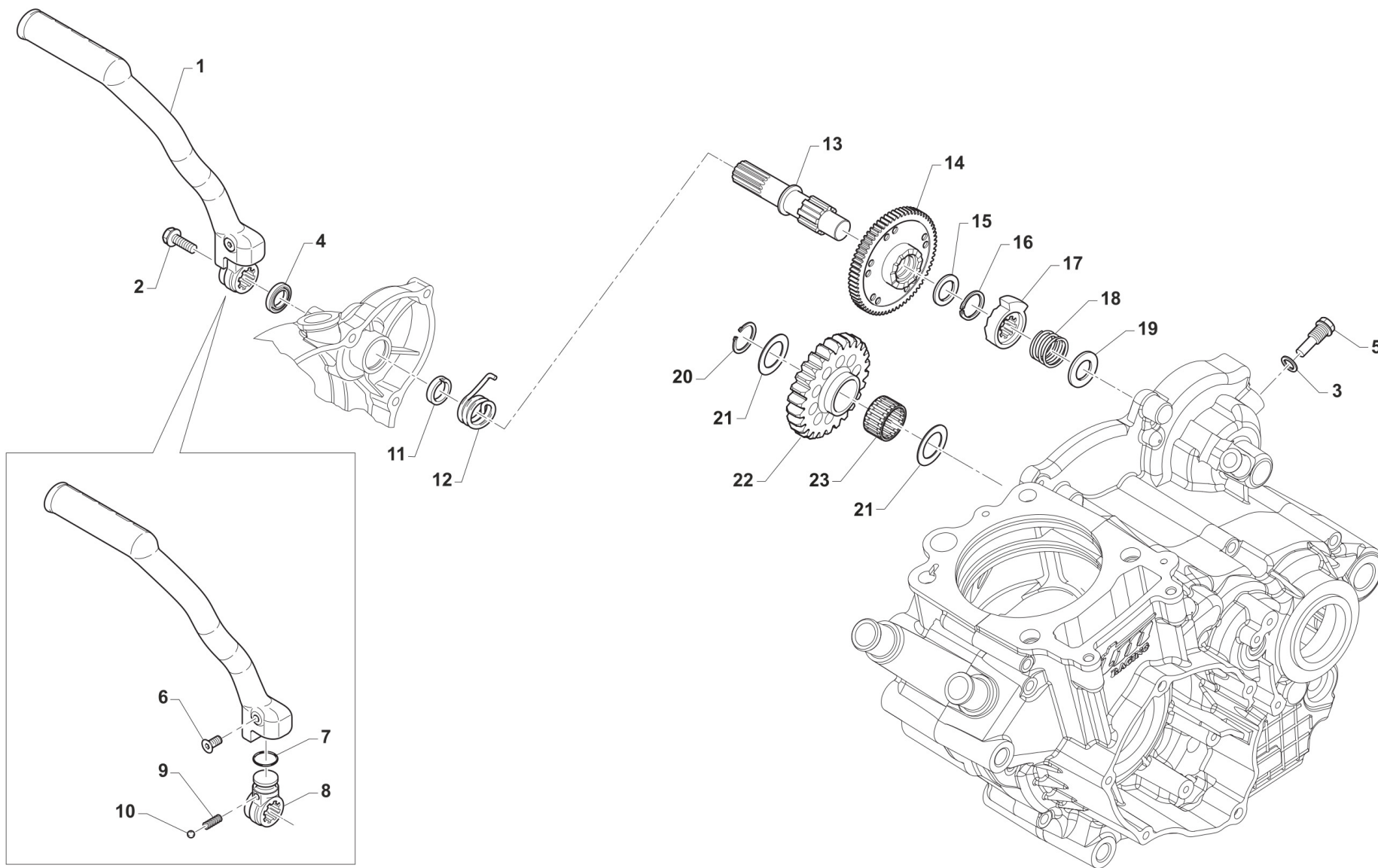

TM0010



4T300FIMX22-M
MOTORE - ENGINE

AVVIAMENTO PEDALE
KICK STARTER

10

Pos.	Codice	Q.tà	Note	Descrizione	Description
1	F43369	1		LEVA M/M 250 Fi M. 10/->	LEVER, K/STARTER 250Fi 10/->
2	49369	1		VITE TE F/R 8X10 Ch.10 M/M	BOLT 8X10 T.10mm(Kich Starter)
3	F49939	1		RONDELLA RAME 8 X13 X 1,5	WASHER COPPER 8,5X13X1,5
4	F04365	1		PARAOLIO LEVA M/M 250/09	OIL SEAL 18x28x6,5 KS LEVER
5	F49825	1		VITE DISIMP.CRICCH.M/M.250Fi	BOLT
6	49414	1		VITE TSPEI 6X30 NORMALE UNI 5933	BOLT TSEI 6X30
7	12260	1		O RING INTERNO LEVA M/M 250	O-RING INT.LEVER KICK START250
8	F43368	1		MOZZETTO KICK START 250N 08	BLOCK, KICK STARTER 250N 08->
9	16039	1		MOLLA X SFERA LEVA M/M 250 CC	SPRING, BALL KICK-START. 250cc
10	43250.03	1		SFERA 1/4C X LEVA M/M 250 CC	BALL, KICK STARTER LEVER 250cc
11	F26423	1		BOCCOLA MOLLA M/M. 250Fi	BUSH
12	F16428	1		MOLLA RICHIAMO AVVIAMENTO A P.	SPRING, KICK STARTER RETURN 4S
13	F28657	1		ALBERO M/M 250Fi	SHAFT, KICK STARTER
14	F40908	1		INGR. COMANDO AVV.PEDALE 250N	GEAR, KICK START
15	F48355	1		SPESSORE TT 18 X 23 X 0,5	SHIM 18 X 23 X 0,5
16	F49835	1		SEEGER AV 18	SEEGER
17	F26424	1		BUSSOLA A CRICC.X K.S. 250N	K.STARTER STOPPER CAM 250 4S
18	F16429	1		MOLLA CRICCHETTO AVV.A PEDALE	SPRING
19	F48354	1		SPESSORE TT 14 X 30 X 0,5	SPACER
20	49253	1		SEEGER E17 INGR.FOLLE M/M 250	CIRCLIP, INTERMED.GEAR K.S.250
21	48012	2		RASAMENTO A/S M/M SPESS.0,5	SPACER, 26x17x0,5
22	F40892	1		INGRANAGGIO FOLLE K.S. 250F 08	GEAR, KICK START
23	19011	1		GABBIA A RULLI K 17X21X10	BUSH CAGE 17 X 21 X 10

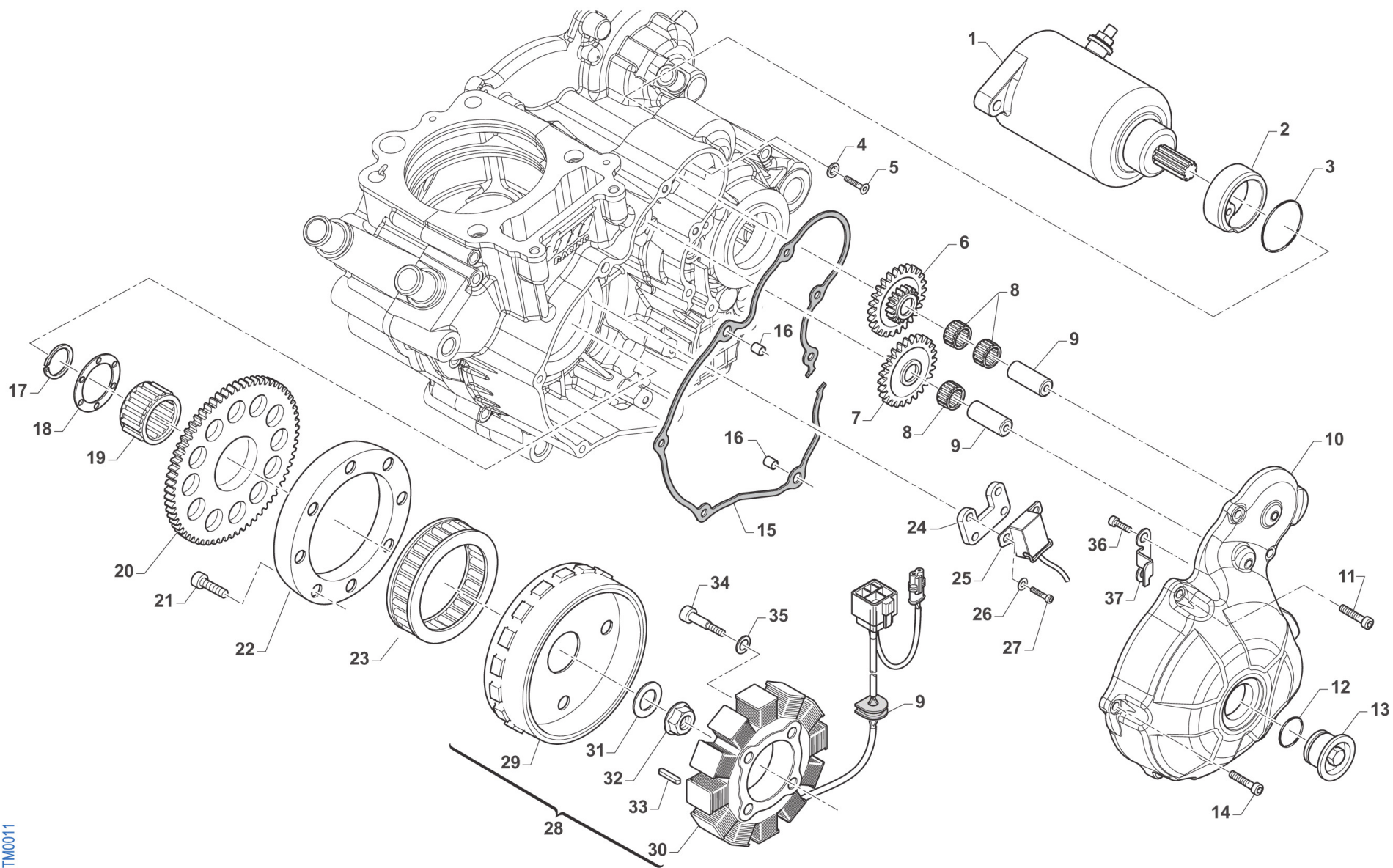

TM0011



4T300FIMX22-M
MOTORE - ENGINE

ACCENSIONE ES
IGNITION ES

11

Pos.	Codice	Q.tà	Note	Descrizione	Description
1	F68145	1		MOTORINO AVVIAMENTO 250N M08 SM 14 A8323-048-00-000	E-STARTER ENGINE 250 4 S 08->
2	F26341	1		BOCCOLA CENTRAGGIO MOT.AVVIAM.	COLLAR, EL. STARTER
3	F12309	1		O RING 2150	O-RING, 2150
4	F49818	1		ROSETTA SPECIALE D.6 SVASATA	WASHER SPECIAL D.6
5	49399	1		VITE TSEI 5X12	BOLT TSEI 5x12
6	F40839	1		INGRANAGGIO DOPPIO RINF. E.S.	GEAR, ELECT. START
7	F40808	1		INGR. FOLLE AVVIAMENTO EL.	INTERMEDIATE GEAR
8	F19501	3		GABBIA A RULLI 10X13X10 4T	NEEDLE CAGE 10X13X10 F.S.
9	F28568	2		ALBERINO LUNGO ING. AVV.ELETTR	SHAFT, EL. STARTER GEAR
10	F30963	1		COP. ACC. 250Fi MX/ES 10/-> ATTACCO ACCENSIONE 4 FORI	COVER IGNITION 250Fi MX/ES10->
11	49477	2		VITE TCEI 5X25 UNI 5931	BOLT TCEI 5X25
12	F12322	1		O RING 2106	O-RING
13	F49833	1		TAPPO COPERCHIO ACC.250Fi	COVER CAP ALUMINIUM 250Fi
14	49476	5		VITE TCEI 5X20 UNI 5931	BOLT TCEI 5X20
15	F05829	1		GUARNIZ.COP.ACCENSIONE ES 250N	GASKET, INGNIT.COVER ES 250Fi
16	26041	2		GRANO CENTRAGGIO D.7X8 F.5,2	DOWEL PIN 7 x 8 Hole 5,2
17	F49937	1		SEEGER ALBERO E 36 4T	CIRCLIP 36 CRANKSH. E 4S
18	F26327	1		RONDELLA ACC. 37X53X2 4T	WASHER 37X50X2 4S.
19	F19506	1		GABBIA A RULLI AVV.EL.37X42X17	NEEDLE CAGE 37X42X17 E.S.
20	F40807	1		INGR. CONDOTTO AVVIAMENTO EL.	GEAR EL. STARTER
21	F49929	8		VITE TCE BASSA 6X16 (CL. 12.9)	SCREW TCE 6 X 16
22	F26385	1		ANELLO ESTERNO PESANTE R.L.KOK	EXTERNAL RING IGNITION KOKUSAN
23	F03354	1		RUOTA LIBERA MOTORINO AVV. 4T	FREE-WHEEL ELECTRIC STARTER
24	F08075	1		PIASTRINO PICK-UP 250Fi MX/ES	
25	F15478	1		PICK-UP KOKUSAN	PICK-UP KOK PU5157
26	49601	2		RONDELLA 5X11	WASHER 5x11



4T300FIMX22-M
MOTORE - ENGINE

ACCENSIONE ES
IGNITION ES

11

Pos.	Codice	Q.tà	Note	Descrizione	Description
27	49452	2		VITE TE 8X30	
28	F15561	1		GENERATORE KOKUSAN MX E.S. KOK / SUMIT. 2V	GENERATOR KOKUSAN MX E.S.
29	F15549	1		ROTORE KOKUSAN YF9019	ROTOR, KOKUSAN YF9019
30	F15547	1		STATORE KOKUSAN YS 9018 C. KOK / SUM	
31	49613	1		RONDELLA ACCIAIO 12	STEEL WASHER 12
32	49056	1		DADO ACCENS 100/TAG/KZ 125MX/E	NUT, IGNITION 100cc
33	F49853	1		CHIAVETTA 5X3X25 UNI7510R.F.A.	WOODRUFF KEY, 5x3x25
34	49384	4		VITE TCEI 4X35	
35	49866	4		RONDELLA 4 x 12 x 1	
36	49553	2		VITE TCEI 4X8	BOLT TCEI 4X8
37	F30945	1		PROTEZIONE CAVI ACC.NE 250N	PROTECTION IGNITION WIRES 250N