



USES AND
RACOMMENDS



www.tmracing.it

TM Racing SpA - Via Fano, 6
61122 Pesaro - ITALY
Phone: +39 0721 25113

2T100MXJ22-M

MOTORE
ENGINE

24/11/2021



INFORMAZIONI GENERALI

Il presente catalogo serve per richiedere con esattezza le parti di ricambio.

Nelle ordinazioni indicare:

1) Il numero di matricola del Telaio che è stampigliato sul lato destro del canotto di sterzo. Nei modelli EN, SMR, SMR il numero di matricola è riportato anche su una targhetta posta sul lato sinistro (Vedi foto).

2) il numero di serie del Motore. E' posto sulla sinistra del motore tra la leva cambio e i coperchio accensione (Vedi foto).

3) Il codice dei particolari seguito dalla descrizione.

4) Il colore per i pezzi verniciati o comunque colorati.

Le indicazioni destra e sinistra si riferiscono ai lati del veicolo rispetto al senso di marcia.

Foto e disegni sono solo a scopo informativo e potrebbero non corrispondere esattamente alle caratteristiche dei prodotti.

GENERAL INFORMATION

The present spare parts catalogue enables one to order exactly the right spare part.

When ordering specify:

1) The frame serial number. It is embossed on the right side of the steering metal tube. In the EN, SMR and SMR models, the serial number is also stated on a plate positioned on the left hand side (See photo).

2) The engine serial numer. It is located on the left side of the engine between the gear lever and the ignition cover (See photo).

3) The part's code number followed but its description.

4) Indicate colour for painted or colored parts.

References to right and left apply to the vehicle in terms of its direction of movement.

Photos and drawings are for informational purposes only and may not exactly match the characteristics of the products.

NOTE – LEGENDA

MY

NOVITA' INTRODOTTA DIFFERENTE O NON PRESENTE NEL MODELLO DELL'ANNO PRECEDENTE

PART DIFFERENT OR NOT PRESENT IN THE REVIOUS YEAR MODEL

5M

MOTORE CON CAMBIO A 5 MARCE
ENGINE WITH 5 GEARS SPEED

6M

MOTORE CON CAMBIO A 6 MARCE
ENGINE WITH 6 GEARS SPEED

KS

MOTORE CON SOLO KICK STARTER
ENGINE WITH KICK STARTER ONLY

ES

MOTORE CON AVVIAMENTO ELETTRICO
ENGINE WITH ELECTRIC STARTER

X

RICAMBIO NON DISPONIBILE ALLA VENDITA
PART CAN NOT BE SOLD SEPARATELY



Le illustrazioni riportate in questo manuale sono fornite solo come riferimento e possono variare dal prodotto effettivo,

Dati indicativi soggetti a modifiche senza impegno di preavviso.

The illustrations in this manual are for reference only and may vary from the actual product.

All data are subject to modification without prior notice.



2T100MXJ22-M
MOTORE - ENGINE

SOMMARIO
TABLE OF CONTENTS

CILINDRO - CYLINDER.....	4
ALBERO MOTORE 18 - PISTONE - CRANKSHAFT 18 - PISTON.....	6
ALBERO MOTORE 20 - PISTONE - CRANKSHAFT 20 - PISTON.....	8
ACCENSIONE - IGNITION.....	10
CENTRIFUGA E CARTER FRIZIONE - WATER PUMP - CLUTCH COVERS.....	12
FRIZIONE - CLUTCH.....	15
BASAMENTO E PACCO.....	18
MESSA IN MOTO - KICK STARTER.....	20
COMANDO CAMBIO - GEARSHIFT MECHANISM.....	22
CAMBIO - GEAR BOX.....	25
VITI COPERCHI.....	28
VITI BASAMENTO.....	30

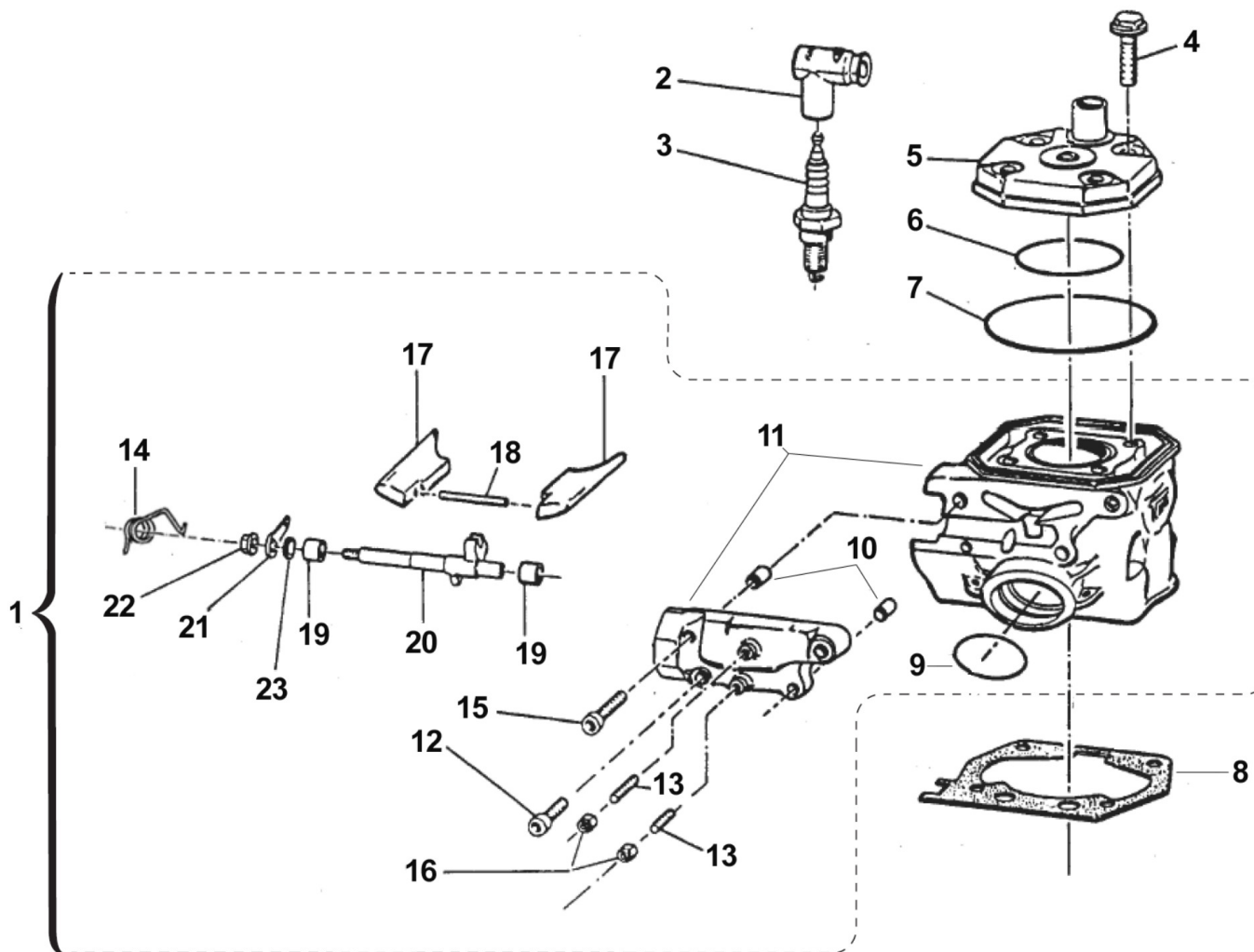



2T100MXJ22-M
MOTORE - ENGINE

CILINDRO
CYLINDER

1

Pos.	Codice	Q.tà	Note	Descrizione	Description
1	01084.19	1		CILINDRO 100 CC CPL MY 2019	
2	21017	1		PIPETTA CANDELA NGK LB05EMH	CAP, NGK SPARK PLUG LB05EMH
3	06028	1		CANDELA NGK BR9ECMIX 85J	SPARK PLUG NGK BR9ECMIX 85cc J
4	49335	4		VITE TE/FLANG. 8X35	BOLT 8X35 FLANGED
5	02090	1		TESTA 100 CR	HEAD 100 MX
6	12005	1		O RING TESTA 85cc PICC. 91/->	O-RING, 56,08 X 1,87
6	12005.1	1		O RING INTER.TESTA 85cc VITON	O-RING HEAD 85 VITON
7	12011	1		O RING CIL.80/85 ESTERNO 03	O-RING, EXTERNAL CYL.80/85cc
8	05519	1		GUARN. B/C 80/85 M.91/-> 0,2	GASKET, CYL 85cc M.91/07 0,20
8	05519.05	1		GUARN. B/C 80/85 M.91/-> 0,05	GASKET, CYL.85cc M.91-> 0,05
8	05520	1		GUARN. B/C 80/85 M.91/-> 0,3	GASKET, CYL 85cc M.91/-> 0,30
8	05521	1		GUARN. B/C 80/85 M.91/-> 0,4	GASKET, CYL 85cc M.91/07 0,40
8	05522	1		GUARN. B/C 80/85 M.91/-> 0,5	GASKET, CYL 85cc M.91/09 0,50
9	12015	1		O RING SCAR.80cc91/02+BOC.CARB	O-RING, EXHAUST 80cc M.91/02
10	26041	2		GRANO CENTRAGGIO D.7X8 F.5,2	DOWEL PIN 7 x 8 Hole 5,2
11	01090.19	1		CILINDRO 100 CR MY 19 NUDO	
12	49474	2		VITE TCEI 5X16 UNI 5931	BOLT TCEI 5X16
13	49705	2		GRANO 5X25 VALV.SC.125 SOPRA	GRUB SCREW 5 X 25
14	16057	1		MOLLA ALBERINO VALV.85 M13 1.5	SPRING EXH.VALVE SHAFT 85cc1,5
15	49476	2		VITE TCEI 5X20 UNI 5931	BOLT TCEI 5X20
16	49633	2		DADO M 5 BASSO AUTOBLOCCANTE	NUT 5mm, LOW SELF-LOCKING
17	22100.19	1		VALVOLE GHIGL. 100cc MY 2019	EXHAUST VALVE 100cc MY19
18	19009	1		RULLINO 4X34.8 V.SC.125 97/01	PIN 4X34,8 EXH.VALVE 125 97/01
19	19045	2		ASTUCCIO A RULLI HK 0810	NEEDLE BUSH HK 0810
20	28026	1		ALBERINO COM VAL.125/250 99/11	SHAFT P.VALVE 125/250 M. 99/05
21	28039	1		PIASTRINO SUP.V 80/125 99/06 250 97/05	UP PLATE, VALVE 80/125 99/06
22	49701	1		DADO M 5 FLANGIATO VALV.	NUT 5mm, FLANGED VALV.
23	04006	1		PARAOLIO VALV.SCARIC.G.8x12x3	OIL SEAL 8 x 12 x 3



2T100MXJ22-M
MOTORE - ENGINE

ALBERO MOTORE 18 - PISTONE
CRANKSHAFT 18 - PISTON

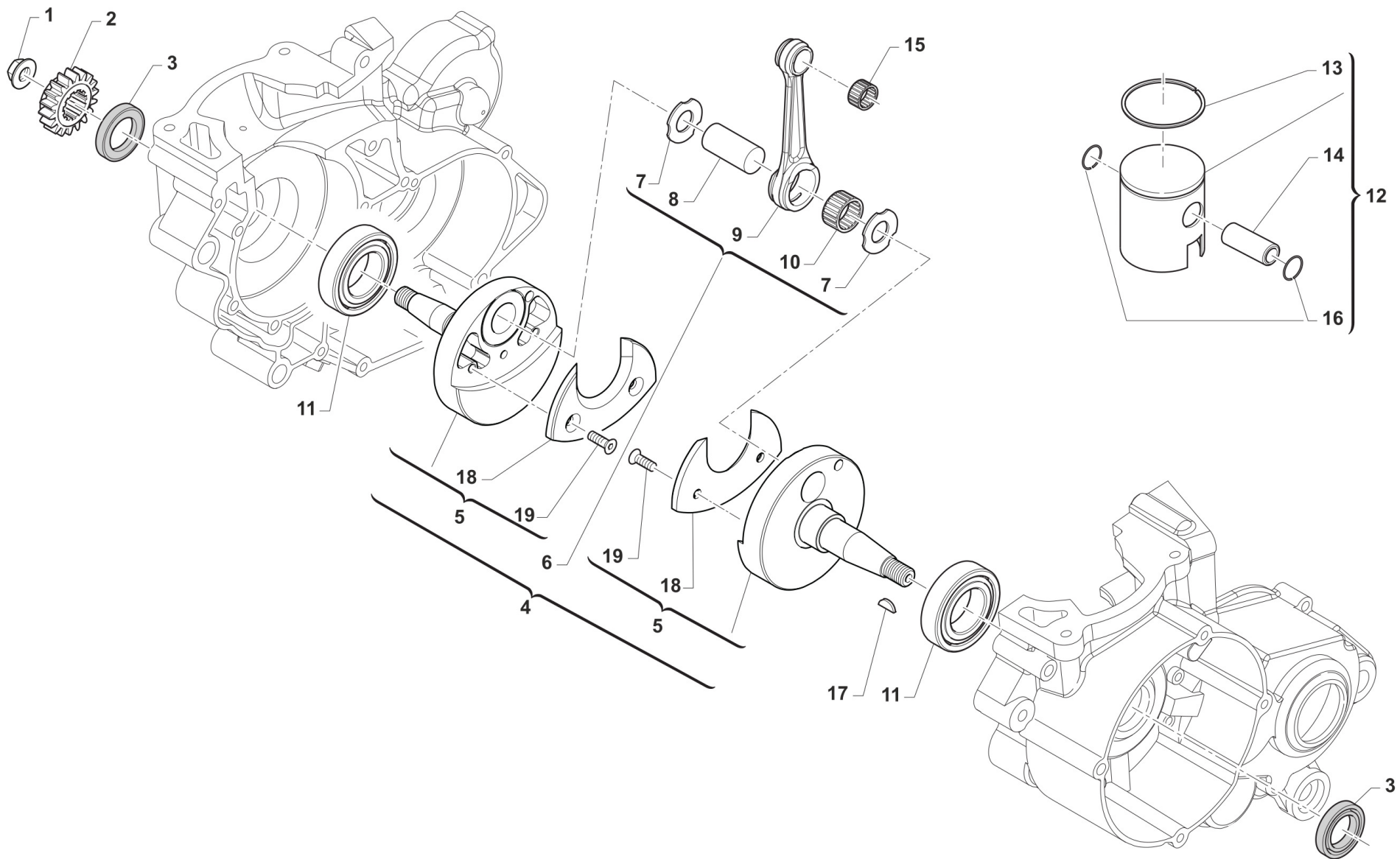

TM0173



2T100MXJ22-M
MOTORE - ENGINE

ALBERO MOTORE 18 - PISTONE
CRANKSHAFT 18 - PISTON

2

Pos.	Codice	Q.tà	Note	Descrizione	Description
1	49056	1		DADO ACCENS 100/TAG/KZ 125MX/E	NUT, IGNITION 100cc
2	40055	1		PIGNONE COPPIA PRIM.Z15 80 M06	PRIMARY DRIVE GEAR 15T 80 M.06
3	04035	2		PARAOLIO 20x30x7 PTFE	OIL SEAL 20 x 30 x 7 PTFE
4	18106.18	1		ALBERO MOTORE 85/100 CPL M. 2018	CRANKSHAFT ASSY 85/100 MY18
5	18209.18	1		COPPIA SEMIALBERI 85/100 MOD. 2018	CRANKSHAFT SIDES 85/100 MY18
6	18104.13	1		BIELLA 85/100cc MOD. 2013 CPL	CONROD ASSY 85cc RACING M.13->
7	18023	2		RONDELLA ARGENTATA D.18	WASHER, SILVER ID.18
8	18022	1		ASSE ACCOPP.18X48K3/K7/KV80/91	CRANKPIN 18X48 K3-K7-KV 80/91
9	18132	1		BIELLA 85 MX/E PROT.2012 NUDA	CONROD 85/100
10	17003	1		GABBIA ARGENTATA D. 18 IKO	SILVER CAGE D.18
11	03020	2		CUSCINETTO RULLI NJ205ET2XC3 (BANCO 85/100 M.18)	BUSH CRANKSHAFT 85/100->18 NJ205ET2XC3
12	10411	1		PISTONE 51,94 100 CC CPL	PISTON, 51,94 100cc ASSY
12	10412	1		PISTONE 51,95 100 CC CPL	PISTON, 51,95 100cc ASSY
13	11060	1		SEGMENTO 100 cc CR.52 X 2 (112)	PISTON RING 100cc CR.52X2
14	09003	1		SPINOTTO PISTONE 80/85 M.91/07	PISTON PIN 80/85/100cc M.91/06
15	19030	1		GABBIA SPINOTTO 80 - 85 - 100 cc	TOP END B. 80cc 85cc 100cc
16	09006	2		ANELLINO FERMA SPINOTTO 80/85/100	CLIP, PISTON PIN 80/85/100cc
17	49010	1		CHIAVETTA VOLANO 13x5x3	WOODRUFF KEY
18	18134.2	2		GUANCETTA AL SEMIALBERO 85/100 M. 2018	
19	49403U	4		VITE TSEI 6x12 UNBRAK UNI 5933	BOLT TSEI 6X12 UMB.



2T100MXJ22-M
MOTORE - ENGINE

ALBERO MOTORE 20 - PISTONE
CRANKSHAFT 20 - PISTON

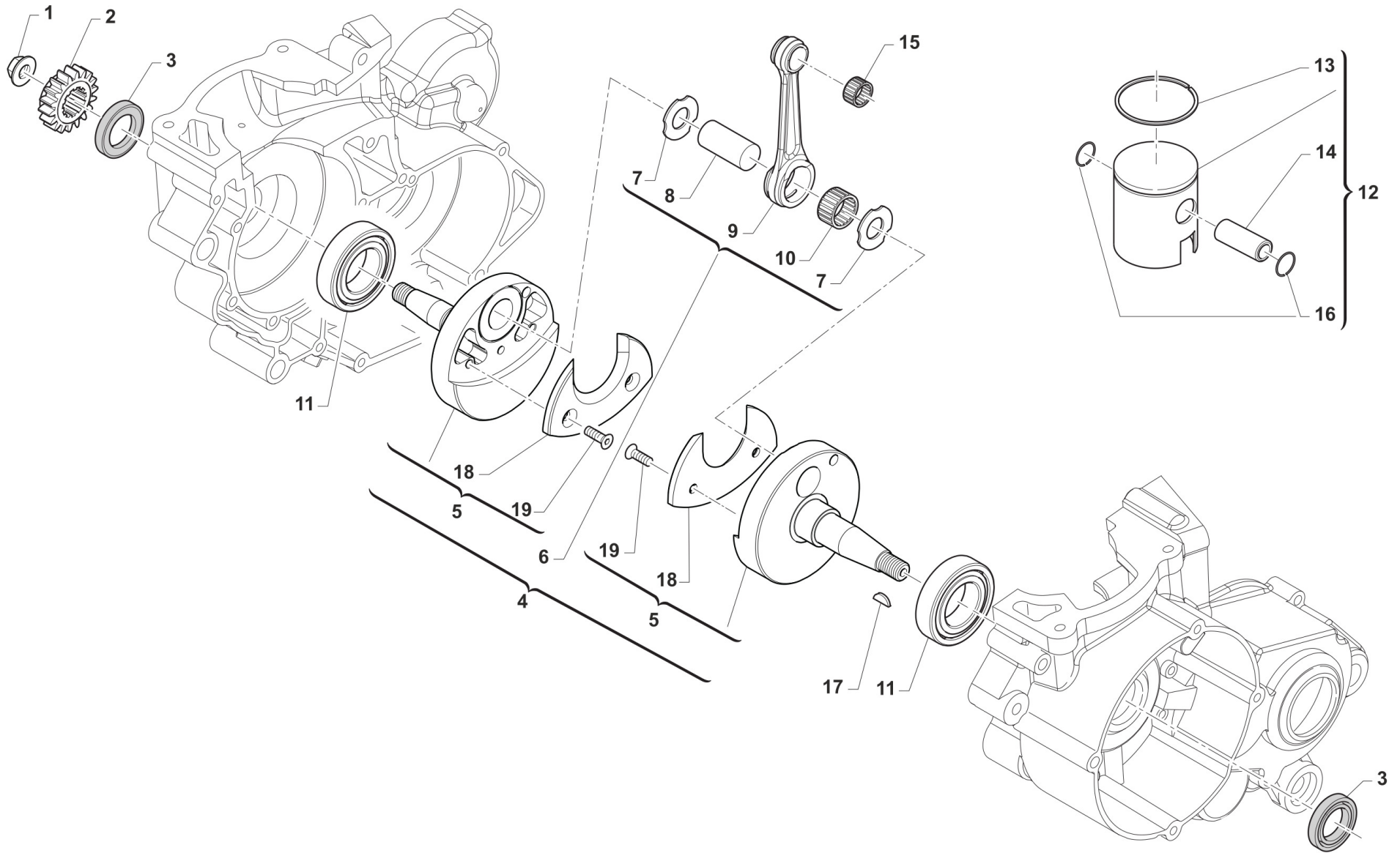

TM0173



2T100MXJ22-M
MOTORE - ENGINE

ALBERO MOTORE 20 - PISTONE
CRANKSHAFT 20 - PISTON

2

Pos.	Codice	Q.tà	Note	Descrizione	Description
1	49056	1		DADO ACCENS 100/TAG/KZ 125MX/E	NUT, IGNITION 100cc
2	40055	1		PIGNONE COPPIA PRIM.Z15 80 M06	PRIMARY DRIVE GEAR 15T 80 M.06
3	04035	2		PARAOLIO 20x30x7 PTFE	OIL SEAL 20 x 30 x 7 PTFE
4	18285	1		ALBERO MOTORE CPL 85/100 USA 20MM	
5	18284	1		COPPIA SEMIALBERI 85/100 USA 20MM	
6	18148	1		BIELLA 85cc D.20 USA CPL	
7	18061	2		RONDELLA ARGENTATA D.20X34X1	WASHER, SILVER ID.20
8	18271	1		ASSE ACCOP. 20 X 48 FORO 5	CON-ROD PIN 20 X 48 H. 5mm
9	18131	1		BIELLA 85cc 2019 ASSE D.20mm L.95 NUDA	
10	17020	1		GABBIA ARGENTATA D. 20 IKO	SILVER CAGE D.20
11	49010	1		CHIAVETTA VOLANO 13x5x3	WOODRUFF KEY
12	10411	1		PISTONE 51,94 100 CC CPL	PISTON, 51,94 100cc ASSY
12	10412	1		PISTONE 51,95 100 CC CPL	PISTON, 51,95 100cc ASSY
13	11060	1		SEGMENTO 100 cc CR.52 X 2 (112)	PISTON RING 100cc CR.52X2
14	09003	1		SPINOTTO PISTONE 80/85 M.91/07	PISTON PIN 80/85/100cc M.91/06
15	19030	1		GABBIA SPINOTTO 80 - 85 - 100 cc	TOP END B. 80cc 85cc 100cc
16	09006	2		ANELLINO FERMA SPINOTTO 80/85/100	CLIP, PISTON PIN 80/85/100cc
17	03020	2		CUSCINETTO RULLI NJ205ET2XC3 (BANCO 85/100 M.18)	BUSH CRANKSHAFT 85/100->18 NJ205ET2XC3
18	18134.3	2		GUANCETTA AL SEMIALBERO 85/100 M. 2019	
19	49403U	4		VITE TSEI 6x12 UNBRAK UNI 5933	BOLT TSEI 6X12 UMB.



2T100MXJ22-M
MOTORE - ENGINE

ACCENSIONE
IGNITION

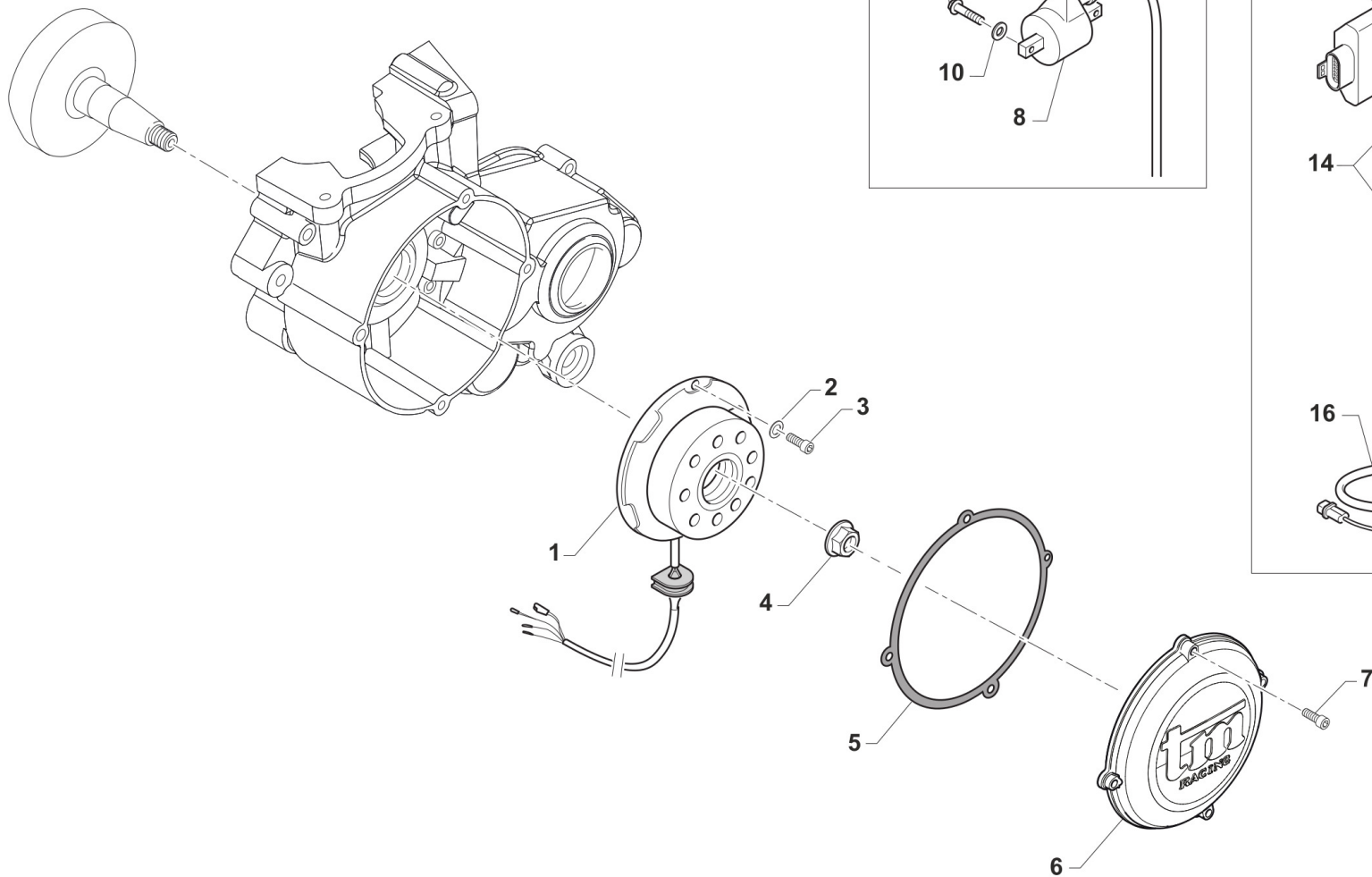

0178.01



2T100MXJ22-M
MOTORE - ENGINE

ACCENSIONE
IGNITION

3

Pos.	Codice	Q.tà	Note	Descrizione	Description
1	15230	1		GENERATORE KOK END 11 MX/E 12	GENERATOR KOK END 11 MX/E 12->
2	49902	2		RONDELLA 6,5X13X3	
3	49484	2		VITE TCEI 6X20	BOLT TCEI 6X20
4	49056	1		DADO ACCENS 100/TAG/KZ 125MX/E	NUT, IGNITION 100cc
5	05516	1		GUARN. COP.ACC. 80/125 KOKUSAN	GASKET, KOK.IGNIT.COV. 80/125
6	30211	1		COP. ACC. MX 125/144 06/11 E11	COVER, IGNITION MX 80/125 2006 KOK.
7	49477	4		VITE TCEI 5X25 UNI 5931	BOLT TCEI 5X25
8	15206	1		BOBINA KOKUSAN PIC. 2T IG7112	COIL, KOKUSAN 2 STROKE IG7112
9	49357	2		VITE TE F/R 6X25 Ch.8	BOLT 6X25 T.8
10	49603	2		RONDELLA M 6,4 X 12 X 1,6	WASHER 6x12
11	15209.085001	1		CENTRALINA TMEES IG_MX 85_01	ECU TMEES IG_MX 85_01
12	F15562	1		SUPPORTO CENTRALINA KOKUSAN	HOLDER ECU KOKUSAN
13	F26537	1		PIASTR.FISS.SUP.ECU KOK.F15562	PLATE HOLDER UCU KOKUS. F15562
14	49633	2		DADO M 5 BASSO AUTOBLOCCANTE	NUT 5mm, LOW SELF-LOCKING
15	49317	2		VITE TB LARGA 5X10 LAT.SERB.94	BOLT TB LARGE 5X10
16	68120	1		CABLAGGIO CDI KOK 2T 08/10	WIRE ECU KOKUSAN 2S 08/10

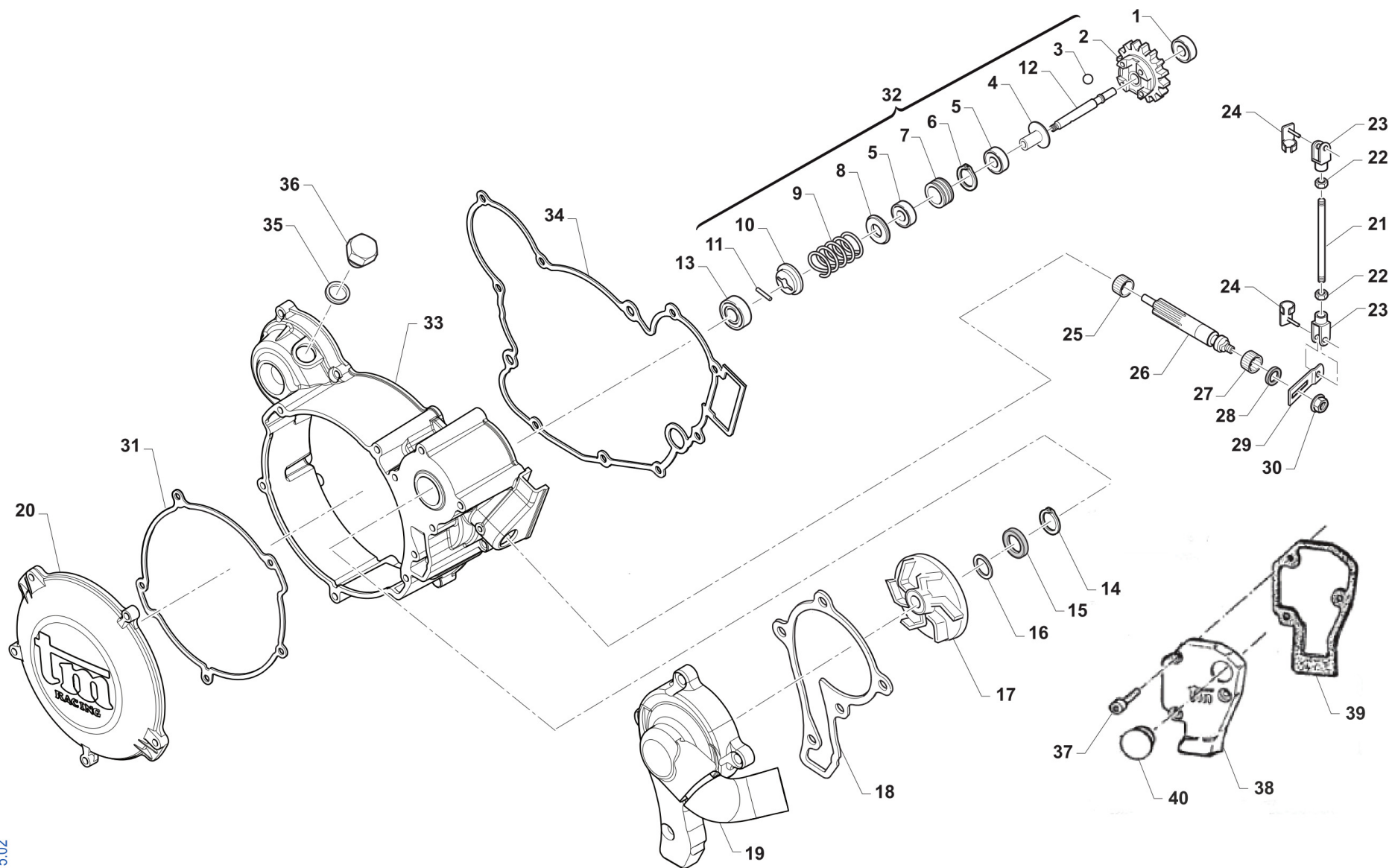

0175.02



2T100MXJ22-M
MOTORE - ENGINE

CENTRIFUGA E CARTER FRIZIONE
WATER PUMP - CLUTCH COVERS

4

Pos.	Codice	Q.tà	Note	Descrizione	Description
1	03025	1		CUSCINETTO 626 C3 POMPA H2O 06	BUSH, WATER PUMP 626 C3
2	40056	1		INGR. VALVOLA CENTRIF. 80 2006	EXHAUST VALVE GEAR 80cc M.06
3	19054	4		SFERA D.12	BALL DIAM. 12 mm
4	40065	1		BUSSOLA PER CENTRIFUGA 10/11	SPIN BUSH 10/11
5	03028	2		CUSCINETTO 61901 MODIFIC 10/11	BUSH, 61901
6	49263	1		SEEGER I 24	SEEGER I 24
7	40059	1		RUOTA DENTATA CENTRIFUGA 10/11	GEAR SPIN WHEEL 10/11
8	48031	1		RONDELLA GUIDA MOLLA ANT.2010	WASHER, SPRING, FRONT
9	16056	1		MOLLA CENTRIFUGA JUNIOR 2013	SPRING, SPIN EXHAUST VALVE J13
10	48024	1		RONDELLA GUIDA MOLLA PST.06(2)	WASHER, SPRING, REAR
11	F19503	1		RULLINO D.3 X 13.8	PIN D.3 X 13,8 F.S.
12	28004	1		ALBERINO POMPA E CENTR.2006	SHAFT, WATERPUMP 2006
13	03014	1		CUSCINETTO 608 ZC3 POMPA SCHER	BUSH, WATER PUMP 608 Z C3
14	49215	1		SEEGER I22 POMPA ACQUA	CIRCLIP D.22 WATER PUMP
15	04017	1		PARAOLIO CENTRIFUGA 06 +MF1TAG	OIL SEAL 8 X 22 X 7 TC
16	49689	1		RONDELLA 6 X 12 SP. 1.2	WASHER 6x12 sp. 1,2
17	28009	1		GIRANTE POMPA ACQUA 2006/08	IMPELLER, WATER PUMP M.06/->
18	05528	1		GUARN. POMPA ACQUA 125 2006	GASKET WATER PUMP 125cc 2006
19	30194.06	1		COPERCHIO POMPA H2O CR/E 06/->	WATER PUMP COVER MX/E M.2006
20	30187	1		COPERCHIETTO FRIZ. 125 M.2006	COVER, CLUTCH, EXT. 125 06/->
21	28045	1		ASTINA VALVOLA 98,5 x 4 112/144 CR 07/08	
22	49630	2		DADO M 4 (BASSO)	NUT 4mm, LOW
23	49041	2		FORCHETTINA M4 X VALVOLA SC.	FORK, POWER VALVE ROD
24	49042	2		MOLLA BLOCCA FORCHETTINA M4	SPRING, POWER VALVE FORK M4
25	19048	1		ASTUCCIO A RULLI HK 0608	NEEDLE CAGE HK 0608
26	28005	1		ALBERINO COM. VALVOLA SC.06/10	SHAFT, INLET VALVE 2006
27	19044	1		GABBIA A RULLI FRENO POST.	NEEDLE BUSH REAR BRAKE PEDAL
28	F04354	1		PARAOLIO G 12X16X3 POMPA OLIO	OIL SEAL G 12/13/3 OIL PUMP



2T100MXJ22-M
MOTORE - ENGINE

CENTRIFUGA E CARTER FRIZIONE
WATER PUMP - CLUTCH COVERS

4

Pos.	Codice	Q.tà	Note	Descrizione	Description
29	28043	1		PIASTRINO INF. VALV. 125/2006	VALVE LOW PLATE 125/2006
30	49701	1		DADO M 5 FLANGIATO VALV.	NUT 5mm, FLANGED VALV.
31	05526	1		GUARN. COP.FRIZ. EST.125 06/->	GASKET, EXT.CLUTCH COVER 125/6
32	28004.85	1		ALBERINO POMP.CENTR 85 CPL 13>	SHAFT, WATERPUMP 85 ASSY 13->
33	30186	1		CARTER FRIZIONE 125 M.06/11	COVER, INT CLUTCH 125 M.06/11
34	05527	1		GUARN. COP.FRIZ. INT.125 06/->	GASKET, CLUTCH CASE 125 06/->
35	49103	1		RONDELLA 14X20X1,5 ALLUMINIO	WASHER, 14 X 20 X 1.5 ALUMINUM
36	49300	1		TAPPO CARICO OLIO	OIL PLUG, FILL
37	49474	3		VITE TCEI 5X16 UNI 5931	BOLT TCEI 5X16
38	30201.02	1		COPERCHIETTO LEV.VALV.C/E80 02	EXT. VALVES COVER MX/END.80 02
39	05514.1	1		GUARN. COP.LEVERAG.80/85 M.02	GASKET, POWER VALVE 85 M.02/09
40	21009	1		TAPPO GOMMA COPERCHIO VALV.SC.	RUBBER, COVER

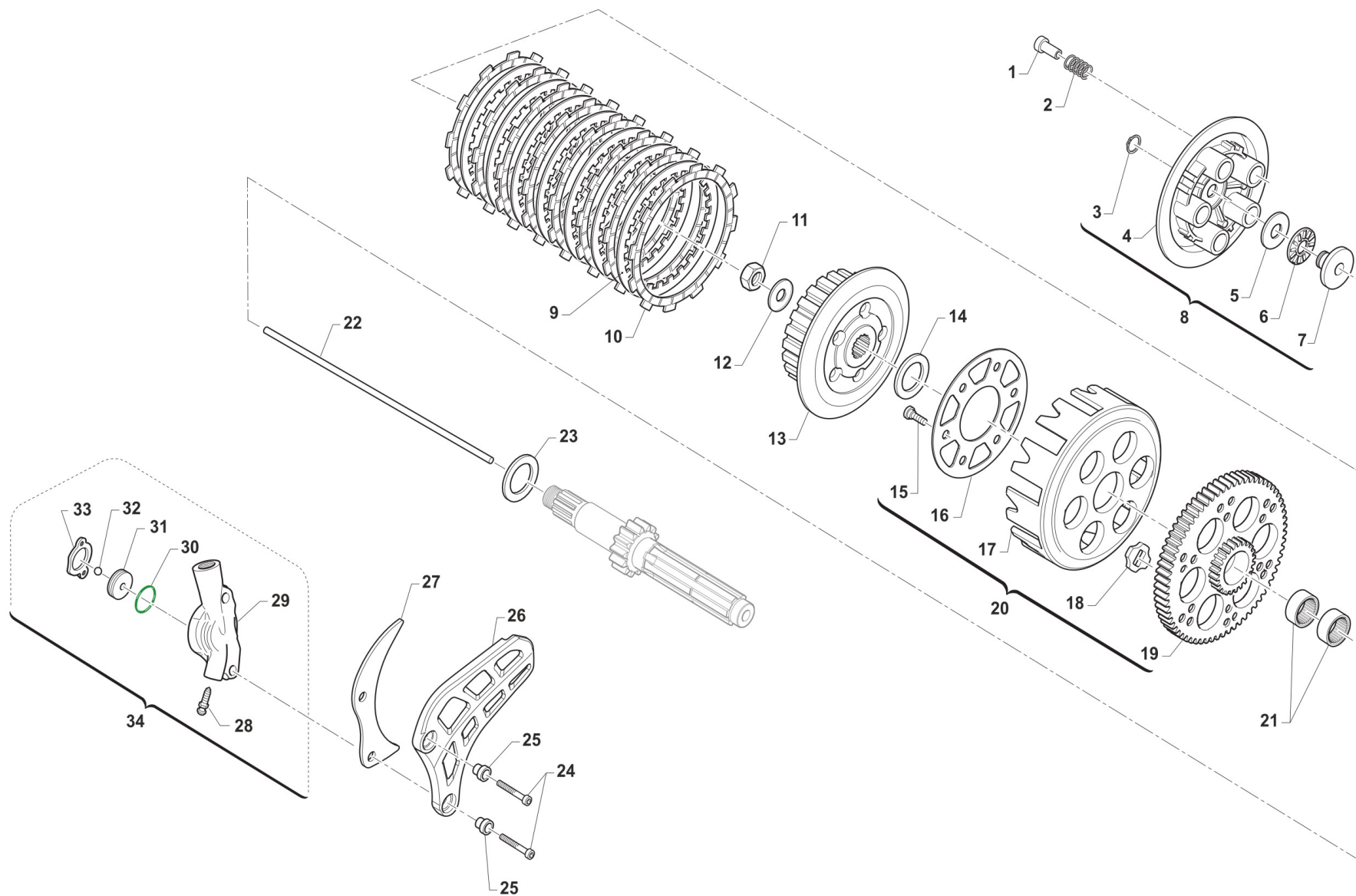

TM0174



2T100MXJ22-M
MOTORE - ENGINE

FRIZIONE
CLUTCH

5

Pos.	Codice	Q.tà	Note	Descrizione	Description
1	49058	5		DADO FRIZIONE ERGAL 85CC 2014	NUT, CLUTCH 85cc ERGAL 14->
2	16020	5		MOLLA FRIZIONE 125 C/E 03/08BA	SPRING, CLUTCH 125 MX/E 03/->
3	49211	1		SEEGER E10x1 ANELLO PIATT.REG.	CIRCLIP D.8,4 - EXTERNAL
4	35015	1		PIATTO SPING. FRIZIONE 125 97->	PLATE, CLUTCH PRESS.125 97/02
5	19021	1		RONDELLA X GABBIA RULLI AS1024	WASHER, NEEDLE CAGE AS 1024
6	19020	1		GABBIA A RULLI RAD. AXK 1024	NEEDLE CAGE AXK 1024, RADIAL
7	26001	1		REGGISPINTA FRIZIONE	CLUTCH THRUST
8	35025	1		PIATTO SPING.FRIZ 125/KART CPL	PLATE, CLUTCH PRESSURE ASSY
9	35019	7		DISCO FRIZ. ACC. 1mm 99/05	CLUTCH PLATE, STEEL 1mm 99/05
10	35012	8		DISCO FRIZ. GUARN.CR/E M.93->	CLUTCH PLATE, FIBER MX/E 93/->
11	49052	1		DADO TAMBURELLO FRIZIONE	NUT, CLUTCH CENTER
12	49127	1		MOLLA A TAZZA DIN 2093 28X14,2X1,25	DISC SPRING DIN 2093 28x14,2x1,25
13	25099.14	1		TAMBURELLO FRIZIONE 125 2014	CLUTCH CENTRE 125cc M.14->
13	50124	1		CHIAVE FRIZ. 85/125 + KART CPL	CLUTCH TOOL 85/125cc + KART
14	48002	1		SPESSORE COP.PRIM.30X18X3	SPACER 30x18x3
15	49727	6		VITE PARASTRAPPI K9 M7X1X12.5	SCREW, M7X1X12,5 K9 ENGINE
16	35026	1		DISCO BATTUTA GOMM. FRIZ.KZ10B	DISC STOP RUBBERS CLUTCH KZ10B
17	25000	1		CAMPANA FRIZ.125 M.91/96 99/13	CLUTCH BASKET 125 91/96 99/05
18	21005	6		GOMMINO PARASTRAPPI FRIZIONE	RUBBER, CLUTCH BASKET
19	40400	1		COPPIA PRIM. 80/85 Z66	PRIMARY GEAR 66T, 80/85
20	40404	1		COPPIA PRIM. 80/85 Z66 CPL/CAM	PRIMARY GEAR 66T, 80/85 Comp.
21	19013	2		GABBIA A RULLI K 20X24X12	NEEDLE CAGE 20 X 24 X 12
22	35043	1		ASTINA FRIZ. IDR. 125 M.99/10	ROD, HYDR.CLUTCH 125 M. 99/04
23	48003	1		SPESSORE COP.PRIM.30X20X2	SPACER 30X20X2 PRIMARY GEAR
24	49486	2		VITE TCEI 6X30 UNI 5931	BOLT TCEI 6X30
25	26212	2		BOCCOLA PROT. PIGNONE 125 F.6	COLLAR, SPROCKET 125cc H.6
26	40029	1		PROTEZIONE PIGNONE 09/-> PLAST	PROTECTION FRONT SPROCKET09/13
27	40022	1		PROTEZIONE ERGAL PIGNONE CAT.	PROTECTION, GEAR CHAIN ERGAL



2T100MXJ22-M
MOTORE - ENGINE

FRIZIONE
CLUTCH

5

Pos.	Codice	Q.tà	Note	Descrizione	Description
28	35264	1		VITE SPURGO OLIO FRIZ.IDR.6X1	SCREW AIR BLED HYDRAUL.CLUTCH
29	30205	1		COP. FRIZ/IDR 80/125 95/11 NUD	OUTPUT H.CLUTCH CYLINDER
30	12259	1		O RING PISTONE FR.125/250VERDE	O-RING, CLUTCH PISTON 125/250
31	35125	1		PISTONE POMPA FRIZ. 125 95/->	PISTON, CLUTCH PUMP 125 95/04
32	19052	1		SFERA 8 X FRIZIONE 250 5/16"	BALL, IDR. CLUTCH PUMP
33	05509	1		GUARN. POMPA FRIZ.IDR. 80/125	GASKET, HYDRAULIC CLUTCH80/125
34	30206	1		COP. FRIZ/IDR 85/125 95/-> CPL	OUTPUT H.CLUTCH CYLINDER CPL.

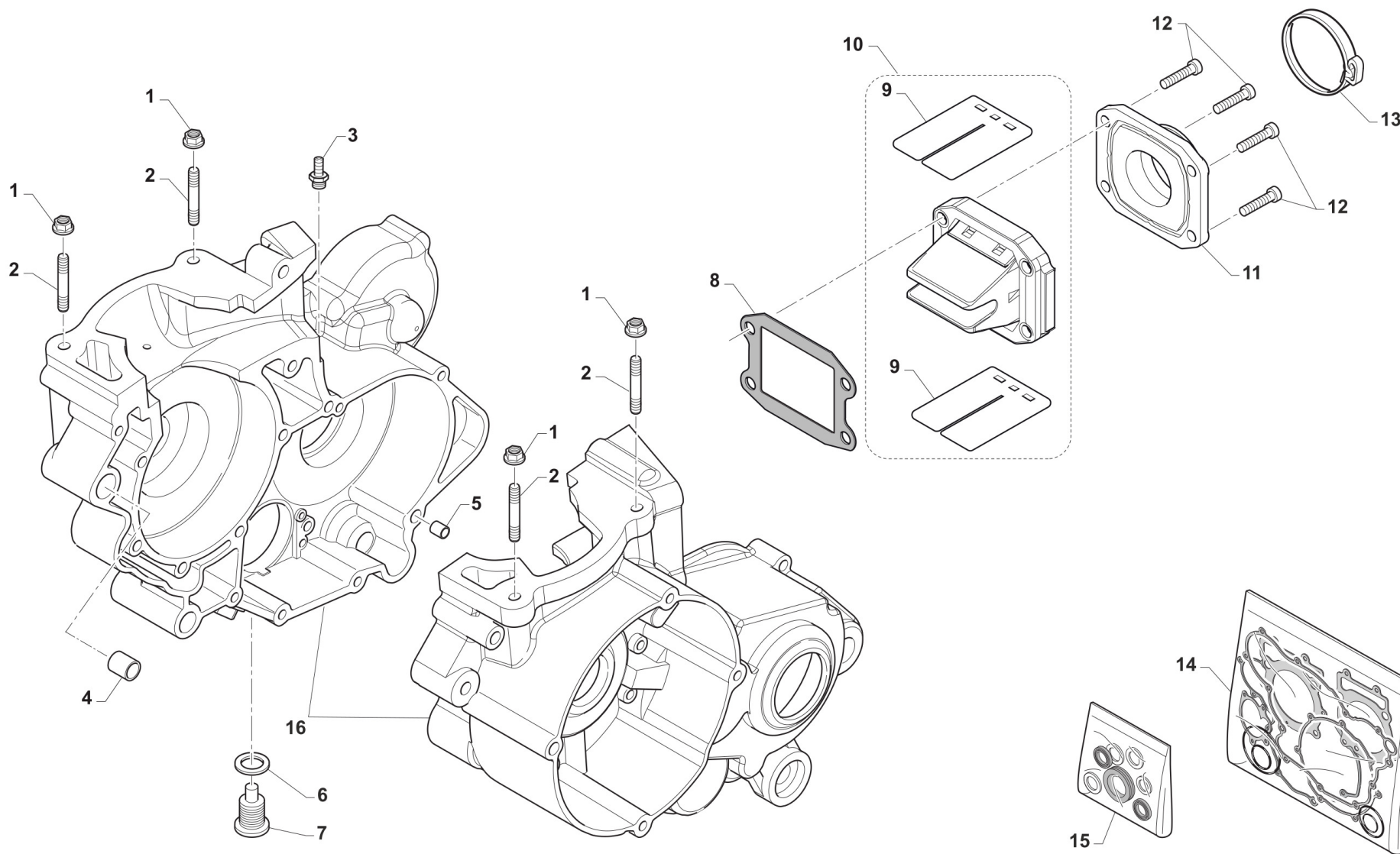

TM0176



2T100MXJ22-M
MOTORE - ENGINE

BASAMENTO E PACCO

6

Pos.	Codice	Q.tà	Note	Descrizione	Description
1	49640	4		DADO M 8 FLANGIATO CHIAVE 12	NUT 8mm, FLANGE
2	49043	4		PRIGIONIERO CIL.M8X48,5 85/100	
3	49002	1		RACCORDO SFIATO VALV.MOT.F.D.3	FITTING VENT VALVE
4	26043	1		GRANO CARTER ANT. 14 X 14	GRUB SCREW 14X14
5	26044	1		GRANO CENTRAGGIO MOTOR.10X13,6	GRUB SCREW 10X13,6
6	49103	1		RONDELLA 14X20X1,5 ALLUMINIO	WASHER, 14 X 20 X 1.5 ALUMINUM
7	49301	1		TAPPO OLIO C/CALAM. 2T	OIL PLUG WITH MAGNET
8	05262	1		GUARN. PACCO LAMELLE 80/85	GASKET, REEDS VALVE 80/85cc
9	20075	1		LAMELLE V-FORCE3 85/100 08/->	REEDS, V-FORCE3 85/100 08/->
10	20084	1		PACCO LAMELLARE 85/100cc 2008 VF3	REEDS BOX 85/100 2S V-FORCE 3
11	13095	1		COLLETTORE ASP.80/85*13 KEI.28	INLET MANIFOLD 85 13-> KEIH.28
12	49484	4		VITE TCEI 6X20	BOLT TCEI 6X20
13	51063	1		FASCETTA SM9 D.40	CLAMP SM9 D.40mm
14	05616.07	1		KIT GUARN. 85/100 MOD. 07/->	GASKETS + OR 85/100 07/->
15	04037	1		KIT PARAOLI 85/100 MOD. 2016/2018	OIL SEAL 85 / 100 MY 18->
16	30028.16	1		BASAMENTO MOTORE 100cc MOTO 2016	



2T100MXJ22-M
MOTORE - ENGINE

MESSA IN MOTO
KICK STARTER

7

Pos.	Codice	Q.tà	Note	Descrizione	Description
1	43038	1		LEVA M/M 80/125 M. 99/->	LEVER, KICK STARTER 125 99/->
2	49368	1		VITE TE F/R 6X10 LEVA M/M	BOLT 6X10 (Kich Starter)
3	04005	1		PARAOLIO ALBERINO M/M 15x24x7	OIL SEAL 15 x 24 x 7
4	26005	1		DISTANZIALE MOLLA M/M	SPACER, KICK STARTER SPRING
5	16008	1		MOLLA M/M 80 / 125 / 144 cc	SPRING, KICK STARTER
6	49406	1		VITE TSEI 6X20	BOLT TSEI 6x20
7	12260	1		O RING INTERNO LEVA M/M 250	O-RING INT.LEVER KICK START250
8	43039.01	1		MOZZETTO KICK START 125 M. 96 ->	
9	16039	1		MOLLA X SFERA LEVA M/M 250 CC	SPRING, BALL KICK-START. 250cc
10	43250.03	1		SFERA 1/4C X LEVA M/M 250 CC	BALL, KICK STARTER LEVER 250cc
12	48008	1		RONDELLA ALBERO MESSA IN MOTO	WASHER, KICK STARTER SHAFT
13	19010	1		GABBIA A RULLI K 15X19X10	BUSH NEEDLE CAGE 15 X 19 X 10
14	28051	1		ALBERO MESSA IN MOTO 125/144 96/18	SHAFT, KICK STARTER 125 96/05
15	40350	1		INGRANAGGIO SCORREVOLE M/M 125 / 144	SLIDING GEAR, KICK STARTER 125
16	16006	1		MOLLA X INGRANAGGIO M/M	SPRING, KICKSTART SLIDING GEAR
17	26254	1		LEVA BATTUTA M/M 125/250 96/->	STOPPER, KICK STARTER
18	49214	1		SEEGER E15 INGRANAGGIO M/M	CIRCLIP GEAR K.S. 15mm
19	48004	2		SPESSORE INGRANAGGIO M/M	SPACER, K.STARTER GEAR
20	40351	1		INGRANAGGIO LIBERO M/M 125 / 144	GEAR, KICK STARTER 125

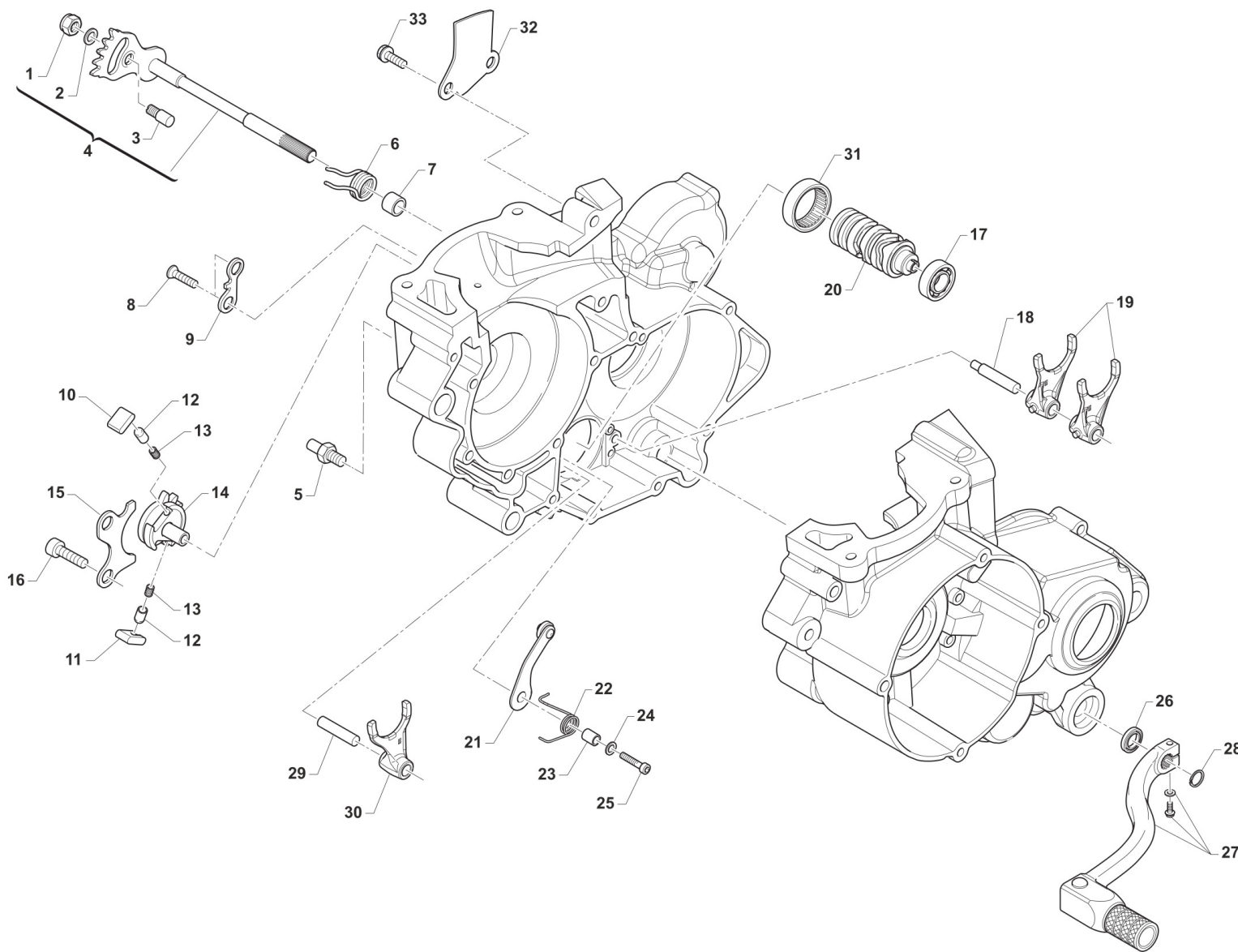

0702



2T100MXJ22-M
MOTORE - ENGINE

COMANDO CAMBIO
GEARSHIFT MECHANISM

Pos.	Codice	Q.tà	Note	Descrizione	Description
1	49638	1		DADO M 6 ALTO AUTOBLOCCANTE	NUT 6mm, HIGHT SELF-LOCKING
2	49603	1		RONDELLA M 6,4 X 12 X 1,6	WASHER 6x12
3	26050	1		BATTUTA ECCENTRICA	ADJUSTER SELECTOR SHAFT
4	28100	1		ALBERO COMANDO ING. P.TACRIC.	SHAFT, GEARSHIFT
5	26051	1		BATTUTA FISSA LEVA CAMBIO INT.	PLATE INT. END STROKE GEAR LEVER
6	16009	1		MOLLA RITORNO LEVA CAMBIO 32CR	SPRING, RETURN GEAR LEVER 3,2
7	26006	1		DISTANZIALE MOLLA LEVA CAMBIO	SPACER, GEAR LEVER SPRING
8	49405	2		VITE TSEI 6X20 UMB.5933 10.9	BOLT TSEI 6x20 U.5933 10.9
9	26022	1		PIASTRINO FINE CORSA	PLATE END STROKE GEAR LEVER
10	26060	1		CRICCHETTO CAMBIO SUPERIORE	RATCHET UP, GEAR
11	26061	1		CRICCHETTO CAMBIO INFERIORE	RATCHET DOWN, GEAR
12	26062	2		PUNTALE PER CRICCHETTO CAMBIO	PIN, RATCHET GEAR
13	16012	2		MOLLA PER PUNTALE	SPRING, GEARBOX PIN
14	40310	1		INGRANAGGIO PORTACRICCHETTI	DRUM SHIFTER GEAR
15	26021	1		PIASTRINO RIENTRO CRICCHETTI	PLATE, RATCHET
16	49483	2		VITE TCEI 6X16 UNI 5931	BOLT TCEI 6X16
17	03012	1		CUSCINETTO DESMODROMICO 6001 2RS	BUSH, 6001 2RS GEAR DRUM
18	33256	1		PERNO FORCH.ALB.SEC. 250 / 125.99	AXEL, COUNTERSHAFT FORK 250cc
19	F33314	2		FORCHETTA A/S 125/250/300 CROM	SHIFT FORK SECONDARY 125/250CR
20	33004	1		ALBERO DESM.125 INTEGR. 6M CPL 125/144 6 M. CPL DI F26476	GEAR DRUM 125 6SP. 125/144 ASSY F26476
21	26063.12	1		PIASTRINO BLOCCAMARCE 2012 CPL	PLATE STOP GEAR ASSY M.12->
22	16252	1		MOLLA BLOCCAMARCE 125 / 250 2T	
23	26007	1		DISTANZIALE MOLLA BLOCCAMARCE	SPACER, STOP GEAR SPRING
25	49485	1		VITE TCEI 6X25 UNI 5931	BOLT TCEI 6x25
26	04004	1		PARAOLIO POMPA H2O-LEVA CAMBIO	OIL SEAL 12 x 22 x 5
27	43048	1		LEVA CAMBIO 2014 + 12MM (253) 85/125/144 2T 250Fi	GEAR LEVER 2014 +12mm
28	49212	1		SEEGER E12 LEVA CAMBIO	CIRCLIP D.12 - EXTERNAL



2T100MXJ22-M
MOTORE - ENGINE

COMANDO CAMBIO
GEARSHIFT MECHANISM

8

Pos.	Codice	Q.tà	Note	Descrizione	Description
29	33255	1		PERNO FORCH.ALB. PRIM.250 / 125.99	AXEL, MAINSHAFT FORK 250cc
30	33016	1		FORCHETTA ALB.PRIM.125 PRT.CRM	SHIFT FORK MAINSHAFT 125 CROM.
31	19041	1		ASTUCCIO A RULLI DHK 35/12	BUSH NEEDLE CAGE DHK 35/12
32	26023	1		PIASTRINO CONVOGLIATORE OLIO	PLATE, OIL
33	49440	2		VITE TE 6X14	BOLT TE 6X14

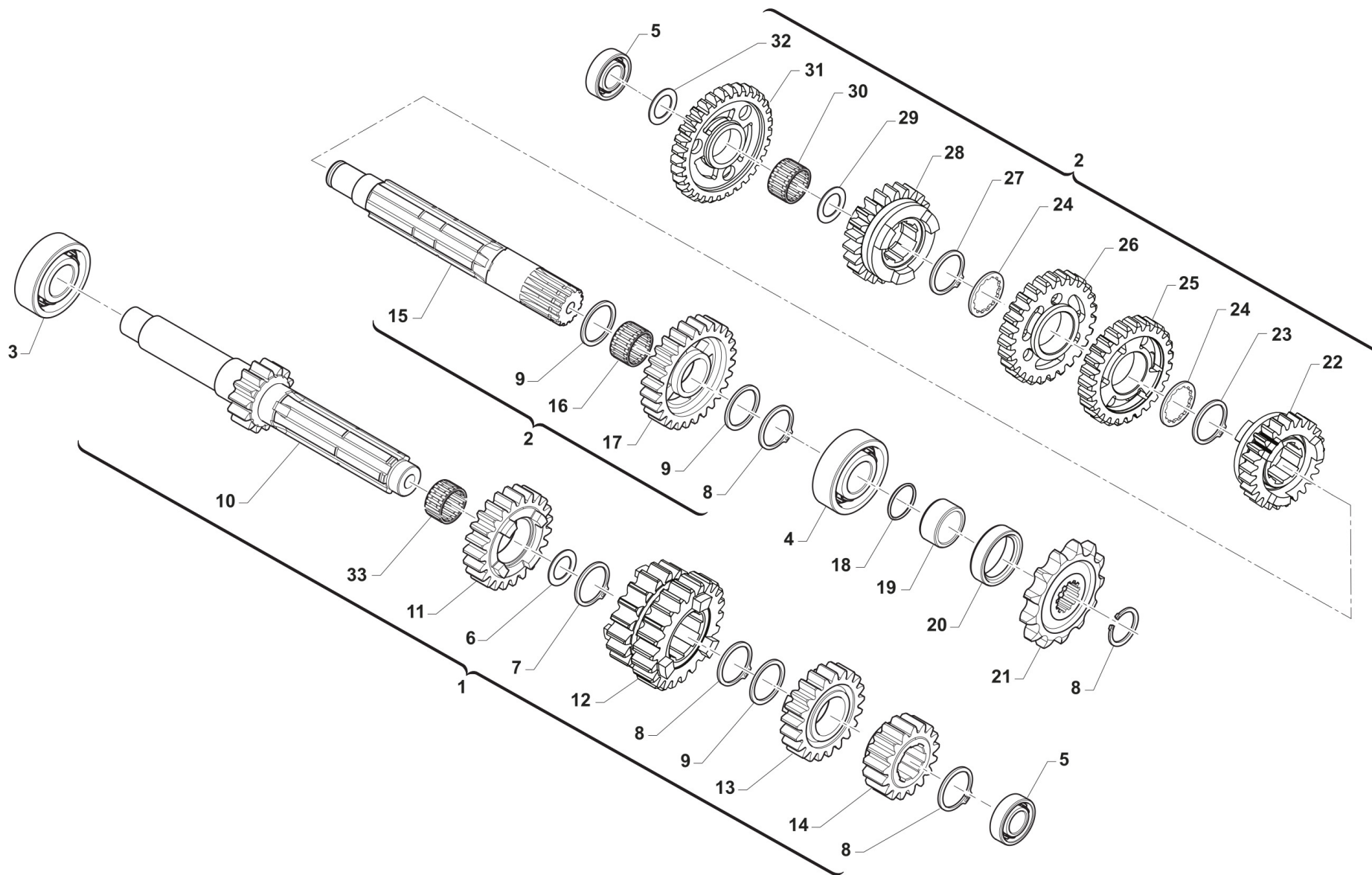



2T100MXJ22-M
MOTORE - ENGINE

CAMBIO
GEAR BOX

Pos.	Codice	Q.tà	Note	Descrizione	Description
1	40003	1		ALBERO PRIMARIO CPL 85/100 CC J/MX	PRIMARY ASHFT ASSY 85/100
2	40004	1		ALBERO SECONDARIO CPL 85/100 CC J/MX	SECONDARY SHAFT ASSY 85/100
3	03011	1		CUSCINETTO ALBERO PRIM. 6204 Z C3	BUSH, GEAR MAINSHAFT
4	03010	1		CUSCINETTO 6204 C3 PIG.CATENA	BUSH, COUNTERSHAFT / SPROCKET
5	03080	2		CUSCINETTO 6202 Z C3 (CON RIVETTI) CAMBIO	BUSH, CRAKSHAFT CLUTCH SIDE
6	48041	1		RASAMENTO A/P 27.5X21X1 KZ10B	SPACER, MAINSHAFT 27,5X21X1 KZ
7	49222	1		SEEGER E 21 mm	CIRCLIP D.21 - EXTERNAL
8	49216	4		SEEGER E20 PIGN.-CAMBIO-COPPIA	CIRCLIP D.20 - EXTERNAL
9	48013	3		RASAMENTO A/S 27X20X0,7	SPACER, 27x20x0,7
10	40713.85	1		ALBERO PRIMARIO Z 14 85CC RINF.CON SEDE SEEGER	PRIMA SHAFT 14T 85/100
11	40440	1		INGR. A.P. 5a Z 22 K9B/C 10 CR/E90	GEAR, 5TH (22T) MAINSHAFT
12	40432	1		INGR A.P. 3/4a Z 19/23	GEAR, 3/4TH (19-23T) MAINSHAFT
13	40451	1		INGR A.P. 6a Z 23	GEAR, 6TH (23T) MAINSHAFT
14	40423	1		INGR A.P. 2a Z 17	GEAR, 2ND (17T) MAINSHAFT
15	40460	1		ALBERO SECONDARIO	COUNTERSHAFT
16	19012	1		GABBIA A RULLI K 20X24X10	BUSH NEEDLE CAGE 20 X 24 X 10
17	40480	1		INGR A.S. 2a Z 29	GEAR, 2ND (29T) COUNTERSHAFT
18	12019	1		O RING PIGNONE CATENA	O-RING, DRIVE GEAR 2075
19	26002.1	1		DISTANZIALE PIGNONE (MOTO)	SPACER, MOTORCYCLE GEAR
20	04003	1		PARAOLIO PIGN.CATENA (26x37x7)	OIL SEAL 26 x 37 x 7
21	40015	1		PIGNONE Z 15 PASSO 1/2X5/16	SPROCKET 15T, DRIVE 1/2X5/16
21	40016	1		PIGNONE Z 16 PASSO 1/2X5/16	SPROCKET 16T, DRIVE 1/2X5/16
21	40017	1		PIGNONE Z 17 PASSO 1/2X5/16	SPROCKET 17T, DRIVE 1/2X5/16
22	40520	1		INGR A.S. 6a Z 23	GEAR, 6TH (23T) COUNTERSHAFT
23	49217	1		SEEGER E22 ANELLO ALB/S	CIRCLIP D.22 - COUNTERSHAFT
24	48011	2		RASAMENTO DENT.A/S 27X22X0,75	SPACER, 27x22x0,75
25	40500	1		INGR A.S. 4a Z 28	GEAR, 4TH (28T) COUNTERSHAFT
26	40490	1		INGR A.S. 3a Z 27	GEAR, 3RD (27T) COUNTERSHAFT



2T100MXJ22-M
MOTORE - ENGINE

CAMBIO
GEAR BOX

Pos.	Codice	Q.tà	Note	Descrizione	Description
27	49217.1	1		SEEGER RETTIFICATO PER 40510	SEEGER RING FOR CODE 40510
28	40510	1		INGR A.S. 5a Z 24 CR/E 90	GEAR, 5TH (24T) COUNTERSHAFT
29	48012	1		RASAMENTO A/S M/M SPESS.0,5	SPACER, 26x17x0,5
30	19011	1		GABBIA A RULLI K 17X21X10	BUSH CAGE 17 X 21 X 10
31	40707	1		INGR A.S. 1a Z 32 CR/90	GEAR, 1ST(32T)COUNTERSH. MX/90
32	48010	1		RASAMENTO ALB/S.28X15X0,5 INGI	SPACER, 28x15x0,5
33	19071	1		GABBIA A 20X24X10 IN DUE META'	NEEDLE CAGE 20X24X10 TWO PIEC.



2T100MXJ22-M
MOTORE - ENGINE

VITI COPERCHI

10

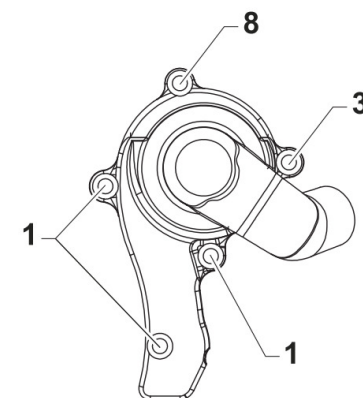
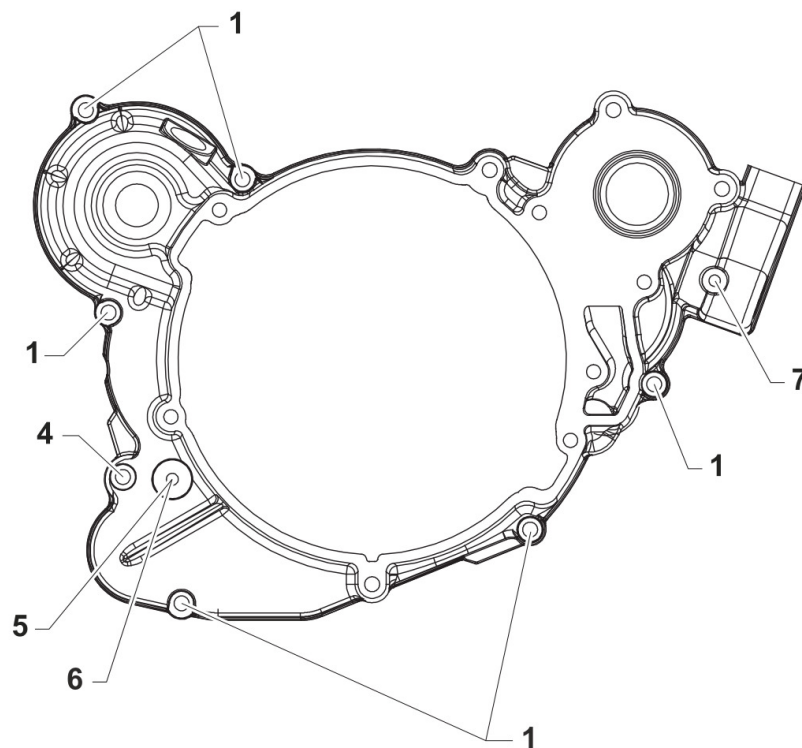
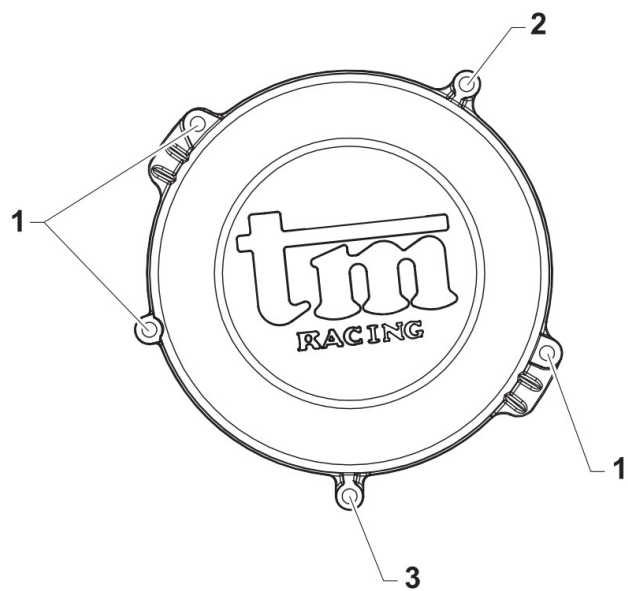

0704



2T100MXJ22-M
MOTORE - ENGINE

VITI COPERCHI

10

Pos.	Codice	Q.tà	Note	Descrizione	Description
1	49476	12		VITE TCEI 5X20 UNI 5931	BOLT TCEI 5X20
2	49563	1		VITE TCEI 6X85	SCREW TCEI 6X85
3	49595	2		VITE TCEI 5X80	BOLT TCEI 5X80
4	49477	1		VITE TCEI 5X25 UNI 5931	BOLT TCEI 5X25
5	49542	1		VITE TCEI 5X10 UNI 5931	BOLT TCEI 5 X 10
6	49104	1		RONDELLA 6 x 10 x 1,5 ALLUMINIO	WASHER 6 x 10 x 1.5 ALUMINUM
7	49593	1		VITE TCEI 4X8 U.	BOLT TCEI 4X8 U.
8	49595	1		VITE TCEI 5X80	BOLT TCEI 5X80



2T100MXJ22-M
MOTORE - ENGINE

VITI BASAMENTO

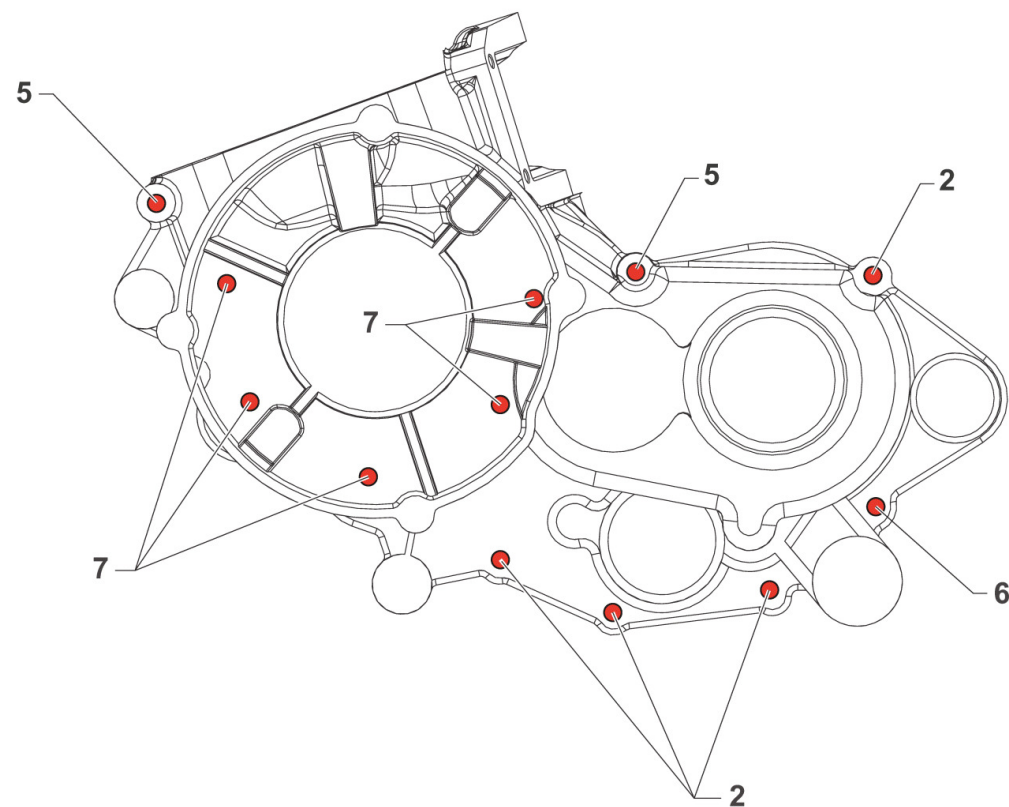
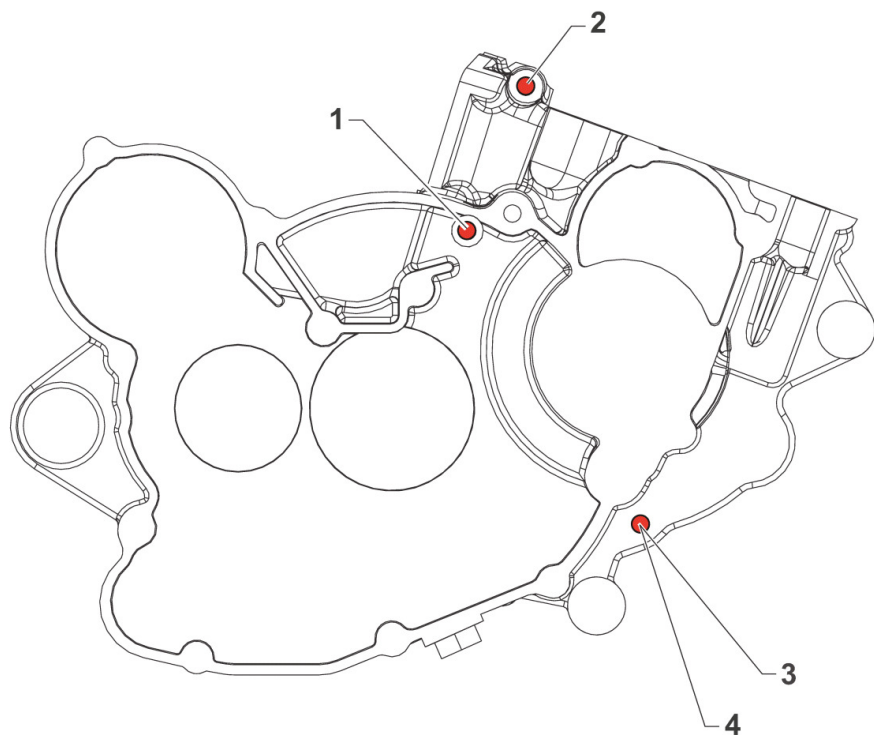



2T100MXJ22-M
MOTORE - ENGINE

VITI BASAMENTO

11

Pos.	Codice	Q.tà	Note	Descrizione	Description
1	49491	1		VITE TCEI 6X55	BOLT TCEI 6X55
2	49409	5		VITE TSEI 6X35	
3	49104	1		RONDELLA 6 x 10 x 1,5 ALLUMINIO	WASHER 6 x 10 x 1.5 ALUMINUM
4	49542	1		VITE TCEI 5X10 UNI 5931	BOLT TCEI 5 X 10
5	49490	2		VITE TCEI 6X50 UNI 5931	BOLT TCEI 6X50
6	49488	1		VITE TCEI 6X40	BOLT TCEI 6x40
7	49489	5		VITE TCEI 6X45 UNI 5931	BOLT TCEI 6x45