



4T300FIEN26-M

4T 300 Fi EN

4S 300 Fi EN

13/11/2025

TM MOTO SRL UNIPERSONALE - VIA FANO, 6 - 61122 PESARO – ITALY

WWW.TM-MOTO.IT



4T300FIEN26-M
4T 300 Fi EN - 4S 300 Fi EN

SOMMARIO
TABLE OF CONTENTS

CILINDRO - PISTONE - CYLINDER - PISTON.....	3
TESTA - HEAD.....	5
ALBERO MOTORE - CRANKSHAFT.....	8
DISTRIBUZIONE - DISTRIBUTION.....	10
LUBRIFICAZIONE - LUBRICATION.....	13
CARTER MOTORE - CLUTCH CASE.....	16
FRIZIONE - CLUTCH.....	18
FRIZIONE (OPEN CLUTCH F1).....	21
COMANDO CAMBIO - GEARSHIFT MECHANISM.....	24
CAMBIO 6M 4T 300 - GEAR BOX 4S 300.....	27
CAMBIO 6M 4T 300 (OPEN CLUTCH F1) - GEAR BOX 4S 300 (OPEN CLUTCH F1).....	30
CENTRIFUGATORE AVVIAMENTO.....	33
ACCENSIONE ES (3 FORI).....	35



4T300FIEN26-M
4T 300 Fi EN - 4S 300 Fi EN

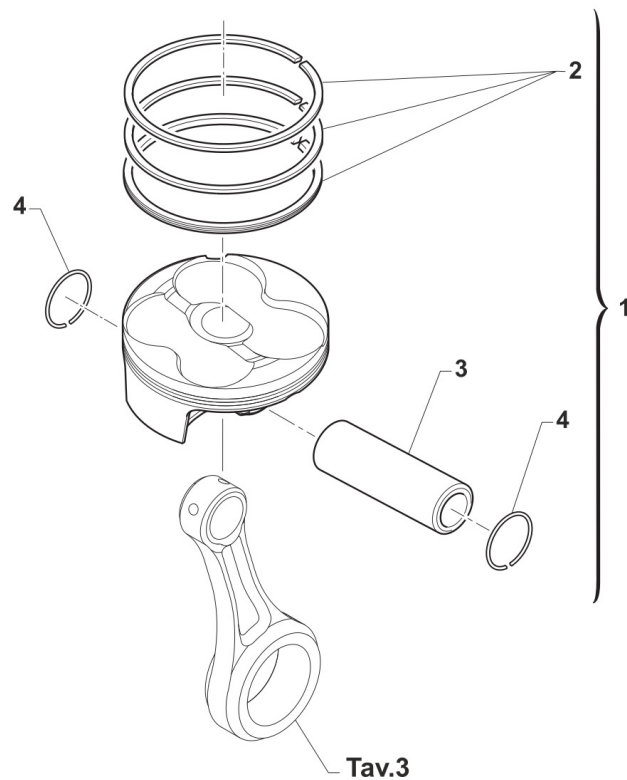

CILINDRO - PISTONE
CYLINDER - PISTON

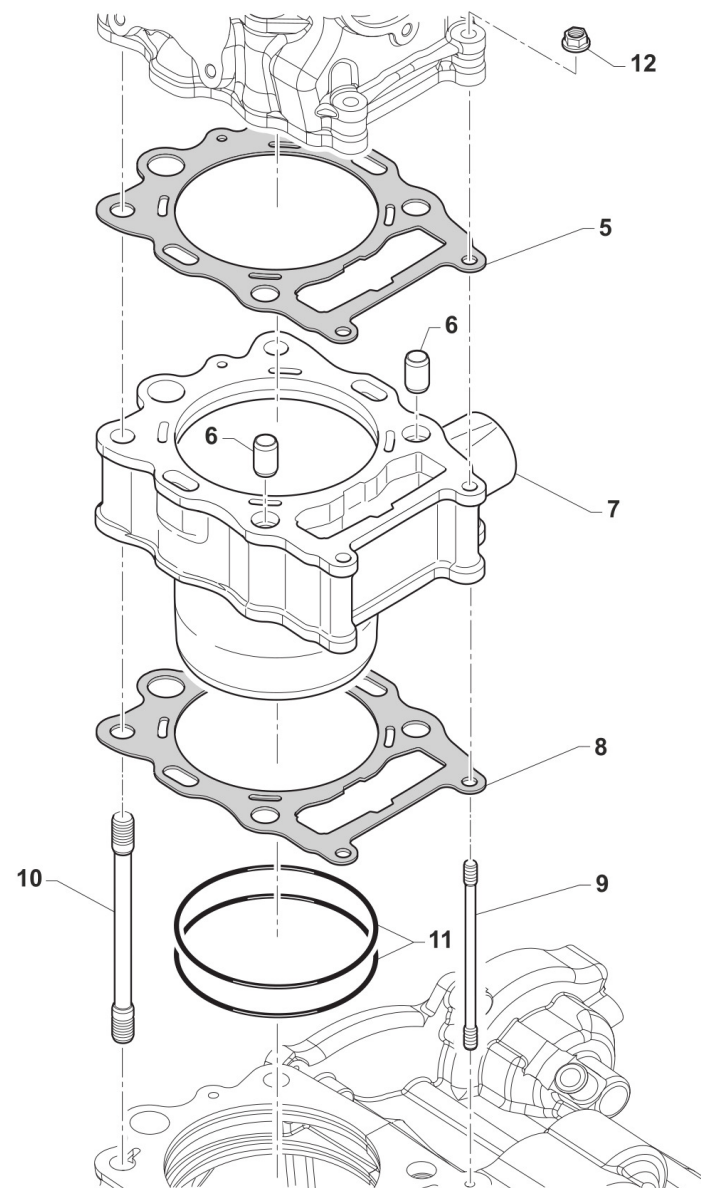

TM0001



4T300FIEN26-M
4T 300 Fi EN - 4S 300 Fi EN

CILINDRO - PISTONE
CYLINDER - PISTON

1

Pos.	Codice	Q.tà	Note	Descrizione	Description
1	F10868.95	1		PISTONE Ø 80,95 C.19,3 300 4T Fi Twin CPL	PISTON Ø 80,95 C.19,3 300 F.S.TWIN Fi ASSY
1	F10868.96	1		PISTONE Ø 80,96 C.19,3 300 Fi Twin CPL	
1	F10868.97	1		PISTONE Ø 80,97 C.19,3 300 Fi Twin CPL	
1	F10868.98	1		PISTONE Ø 80,98 C.19,3 300 Fi Twin CPL	
2	F11409	1		KIT SEGMENTI D.81 NPR	RINGS KIT D.81 NPR
3	F09396.5	1		SPINOTTO 16X9X36 BIC.DLC S2	
4	F09385	2		ANELLINO D.16X1 VP	CIRCLIP D. 16X1 VP
5	F05859.1	1		HEAD GASKET D. 82 mm 3 LAYERS CH	
6	F26428	2		GRANO RIFERIMENTO 12X13 F10.2	GRUB SCREW 12X13 H.10,2mm
7	F01729	1		Cilindro Ø81 h=34,8 mm 300 REPLICA	
8	F05856.1	1		GUARNIZ.CIL/BAS SP.0,2 EVO3 M3	GASKET CYL. TH.0,2 EVO3 M3
8	F05856.2	1		GUARNIZ.CIL/BAS SP.0,3 EVO3 M3	GASKET CYL. TH.0,3 EVO3 M3
8	F05856.3	1		GUARNIZ.CIL/BAS SP.0,4 EVO3 M3	GASKET CYL TH.0,4 EVO3 M3
8	F05856.4	1		GUARNIZ.CIL/BAS SP.0,5 EVO3 M3	GASKET CYL. TH.0,5 EVO3 M3
9	F49875	2		PRIGIONIERO M6X1 /=83 MM A10.9	STUD M 6X1 83MM
10	F49045	4		PRIGIONIERO M10X1,25 L=142,5	STUD M 10X1,25 142,5 MM
11	F12357.1	2		O RING ORM 91,0X2,0 VITON	
12	49676	2		DADO M 6X1 FLANG. AUTOBL.ACC.	NUT, FLANGED M6 X 1 S.B.

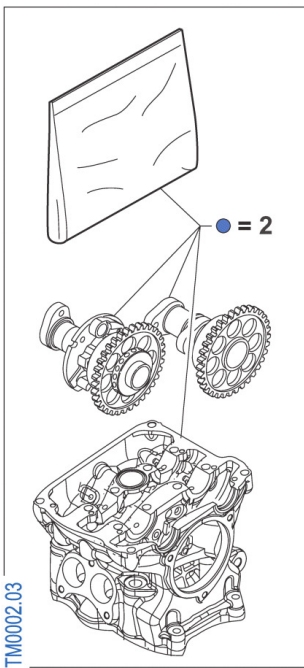
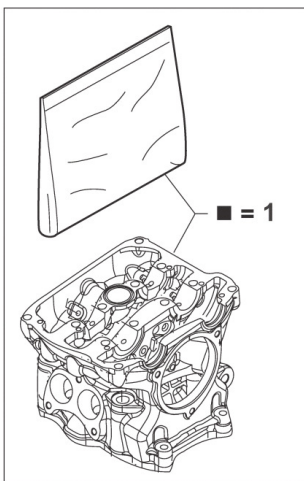

TM0002.03

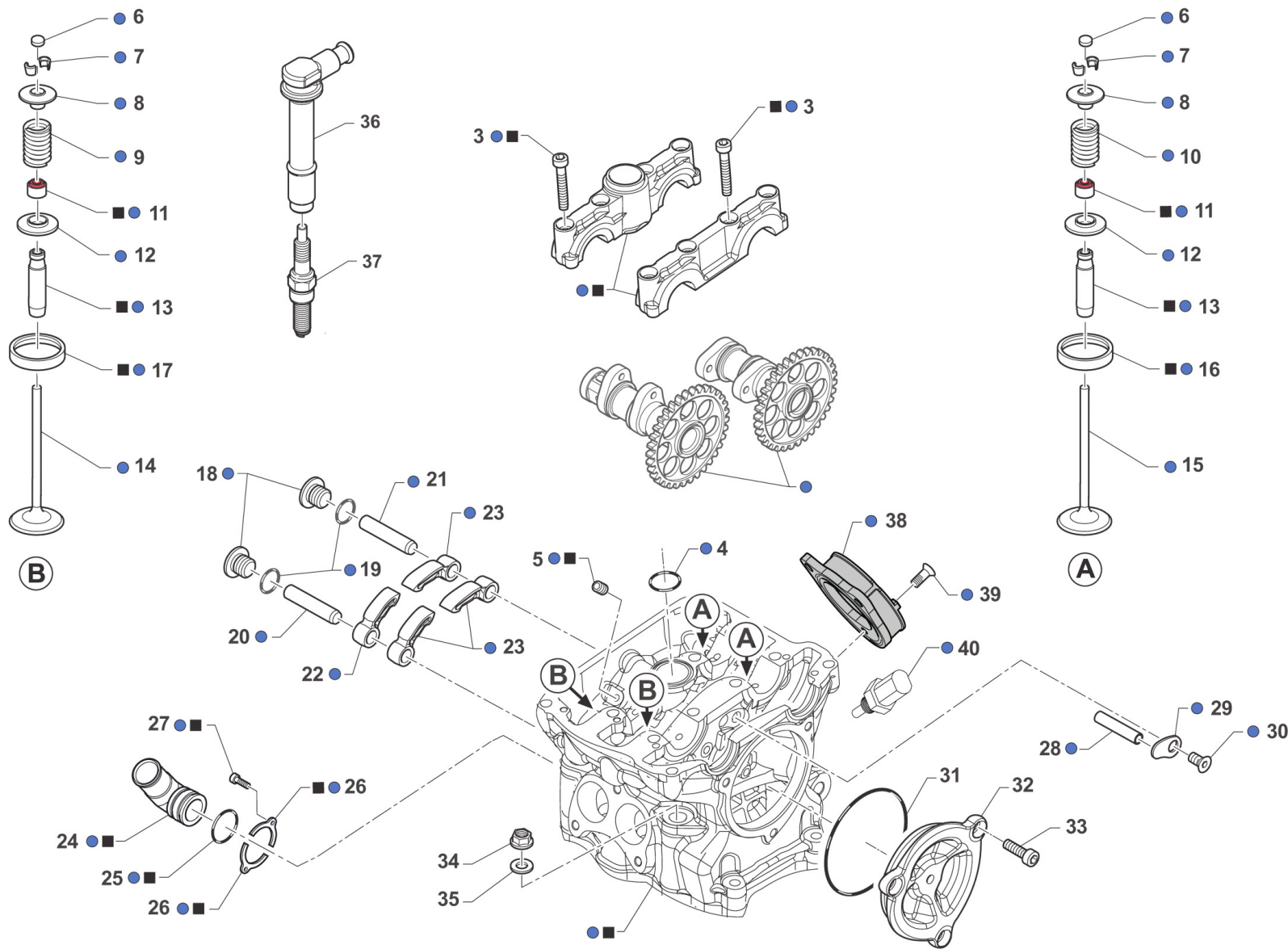



4T300FIEN26-M
4T 300 Fi EN - 4S 300 Fi EN

TESTA
HEAD

Pos.	Codice	Q.tà	Note	Descrizione	Description
1	F02886	1		TESTA 4T 250/300 Fi TWIN SEMI-CPL	
2	F02887.1	1		TESTA 250/300Fi EN TWIN CPL	
3	49487.2	8		VITE TCEI 6X35 UNI 5931-912 12.9 BRUNITE	
4	F12344.1	1		O RING ORM 23,0X1,5 VITON	O-RING 23 X 1,5
5	49702	1		GRANO 5X 6 VALV.SC.MARTELLETTO	GRUB SCREW 5 X 6 INLET VALVE
6	F26603.255	1		PASTIGLIA REGOLAZ. GIOCO Ø 7,26 Sp. 2,55	SHIM, VALVE ADJUSTING Ø 7,26 TH. 2,55
6	F26603.260	1		PASTIGLIA REGOLAZ. GIOCO Ø 7,26 Sp. 2,60	SHIM, VALVE ADJUSTING Ø 7,26 TH. 2,60
6	F26603.265	1		PASTIGLIA REGOLAZ. GIOCO Ø 7,26 Sp. 2,65	SHIM, VALVE ADJUSTING Ø 7,26 TH. 2,65
6	F26603.270	1		PASTIGLIA REGOLAZ. GIOCO Ø 7,26 Sp. 2,70	SHIM, VALVE ADJUSTING Ø 7,26 TH. 2,70
6	F26603.275	1		PASTIGLIA REGOLAZ. GIOCO Ø 7,26 Sp. 2,75	SHIM, VALVE ADJUSTING Ø 7,26 TH. 2,75
6	F26603.280	1		PASTIGLIA REGOLAZ. GIOCO Ø 7,26 Sp. 2,80	SHIM, VALVE ADJUSTING Ø 7,26 TH. 2,80
6	F26603.285	1		PASTIGLIA REGOLAZ. GIOCO Ø 7,26 Sp. 2,85	SHIM, VALVE ADJUSTING Ø 7,26 TH. 2,85
6	F26603.290	1		PASTIGLIA REGOLAZ. GIOCO Ø 7,26 Sp. 2,90	SHIM, VALVE ADJUSTING Ø 7,26 TH. 2,90
6	F26603.295	1		PASTIGLIA REGOLAZ. GIOCO Ø 7,26 Sp. 2,95	SHIM, VALVE ADJUSTING Ø 7,26 TH. 2,95
6	F26603.300	1		PASTIGLIA REGOLAZ. GIOCO Ø 7,26 Sp. 3,00	SHIM, VALVE ADJUSTING Ø 7,26 TH. 3,00
6	F26603.305	1		PASTIGLIA REGOLAZ. GIOCO Ø 7,26 Sp. 3,05	SHIM, VALVE ADJUSTING Ø 7,26 TH. 3,05
6	F26603.310	1		PASTIGLIA REGOLAZ. GIOCO Ø 7,26 Sp. 3,10	SHIM, VALVE ADJUSTING Ø 7,26 TH. 3,10
7	F14178	8		SEMICONO D.5 - 15^ HAYFIELD	VALVE RETAINER D.5 15^HAYFIELD
8	F26597	4		PIATTELLO SUP. MOLLA 4T 250/300	UPPER PLATE
9	F16473	2		SET MOLLA EST. + MOLLA INT. SCAR.	EXTER. & INTER.SPRINGS EXHAUST
10	F16472	2		SET MOLLA EST. + MOLLA INT. ASP.	EXTER. & INTER.SPRINGS INLET
11	F04388	4		ANELLO TENUTA STELO VALV.D.5mm SKF	
12	F26689	4		PIATTELLO T 24X4	LOWER PLATE
13	F26728.1	4		GUIDA VALVOLA SINT. D.5 PER TENUTA SKF BLV077	
14	F14158	2		VALVOLA SCARICO 250/300 Fi 26.8 x 5 TIT	EXHAUST VALVE 250/300 Fi TIT 26.8x5
15	F14164	2		VALVOLA ASPIRAZIONE 250/300 Fi 32 x 5 TIT	INLET VALVE 250/300 Fi TIT 35x5
16	F26557	2		SEDE VALVOLA ASP.250cc	
17	F26558	2		SEDE VALVOLA SCAR.250cc	



4T300FIEN26-M
4T 300 Fi EN - 4S 300 Fi EN

TESTA
HEAD

Pos.	Codice	Q.tà	Note	Descrizione	Description
18	F49871	2		TAPPO ASSE ROT.BILANC.250 M3	PLUG
19	F12325	2		OR ORM 090-15 FILTRO ASP.OLIO 250N	O-RING
20	F28812	1		ASSE ROTAZIONE BIL.SCAR. 250M3	AXLE, ROCKER ARM EXHAUST
21	F28811	1		ASSE ROTAZIONE BIL.ASP.250M3LO	AXLE, ROCKER ARM INTAKE
22	F28836	1		FINGER FOLLOWER WITH DECOM.MIM	FINGER FOLLOWER WITH DECOM.MIM
23	F28835	3		FINGER FOLLOWER NO DECOMP. MIM	FINGER FOLLOWER NO DECOMP. MIM
24	F28841	1		RACCORDO USCITA ACQUA TESTA	JOINT, HEAD WATER
25	F12346.1	1		O RING ORM 18,0X2,0 VITON	O-RING 18 X 2
26	F48374	2		PIASTRINO RITEGNO RACCORDO H2O	PLATE
27	49553	2		VITE TCEI 4X8 5931-912 Brun	BOLT TCEI 4X8
28	F28810	1		ASSE ROTAZIONE BIL.ASP.250M3LC	AXLE, ROCKER ARM INTAKE
29	F48371	1		PIASTRINO BATT.ASSE ROT.BIL.LC	PLATE
30	49944	1		VITE TS 5X12 TORX	
31	F12351.1	1		O RING ORM 61,6X2,4 VITON	O-RING 61,6 X 2,4
32	F30015	1		COPERCHIO ISP. TESTA 250Fi 250 REP.4T	COVER, HEAD, TWIN
33	49481	3		VITE TCEI 6X12	BOLT TCEI 6X12
34	F49874	4		DADO M 10 X 1,25 CH 12 FLANGIATO	NUT FLANGED M 10x1,25 T.12mm
35	F48400	4		RONDELLA Ø10xØ17,5x3	WASHER Ø10xØ17,5x3
36	F21436	1		PIPETTA CANDELA RESISTIVA 250 4T MY18->	CAP, SPARK PLUG
37	F06116	1		CANDELA NGK R0451B-8	SPARK PLUG NGK R0451B-8
38	F13287	1		COLLETTORE ASPIRAZIONE 250Fi 4T REPL.	INLET MANIFOLD 4S 250/300 Fi
39	49989	3		VITE TS 5X14 TORX	BOLT TORX 5 X 14
40	F08003	1		SENSORE TEMP. ACQUA 4T	SENSOR, WATER TEMPERATURE



4T300FIEN26-M
4T 300 Fi EN - 4S 300 Fi EN

ALBERO MOTORE
CRANKSHAFT

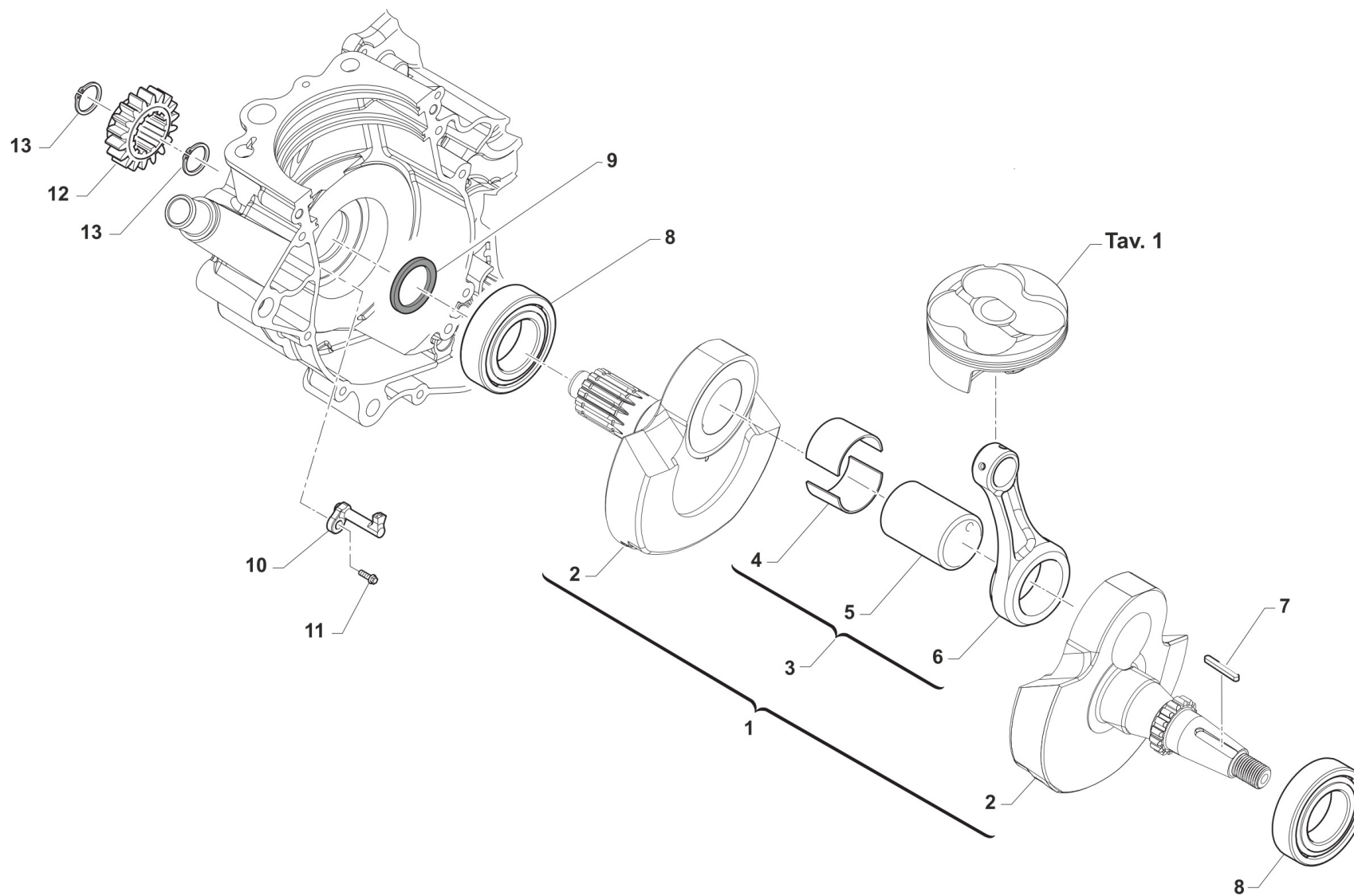

TM 0003.03



4T300FIEN26-M
4T 300 Fi EN - 4S 300 Fi EN

ALBERO MOTORE
CRANKSHAFT

3

Pos.	Codice	Q.tà	Note	Descrizione	Description
1	F18125	1		ALBERO MOTORE 300 FI E.S. 2020 CPL	
2	F18127	1		COPPIA SEMI ALBERI 300 FI E.S. 2020	
3	F18123	1		BIELLA 300FI REPLICA MX/EN CPL (D.34XD.16 I. 98,5)	
4	F03375.4	1		BRONZINA CP BIELLA 30X34X18 BB BLU/BLU	CONNECTING ROD BUSH ASSY 30x34x18 blu
4	F03375.5	1		BRONZINA CP BIELLA 30X34X18 RG ROSSO/GIALLO	BUSH ASSY 30x34x18 RED/YELLOW
5	F18059	1		ASSE ACCOPP. D.30X54,7 X BRONZ	
6	F18104	1		BIELLA D34XD.16 I.98,5 BR	
7	F49853	1		CHIAVETTA 5X3X25 UNI7510R.F.A.	WOODRUFF KEY, 5x3x25
8	03026	2		CUSCINETTO ALBERO MOTORE NJ206 ECP/C3HVC058	BUSH, NJ206 CRANKSHAFT
9	F04375	1		PARAOLIO 25X35X4	
10	F32573	1		UGELLO RAFFREDDAMENTO	NOZZLE
11	49472	1		VITE TCEI 5X12 UNI 5931-912 Brun	BOLT TCEI 5X12
12	F40158	1		PIGNONE TRASM.PRIMARIA Z20 SCANAL.	
13	49255	2		SEEGER RETTIFICATO CAMBIO 250	CIRCLIP, GEAR BOX 250cc

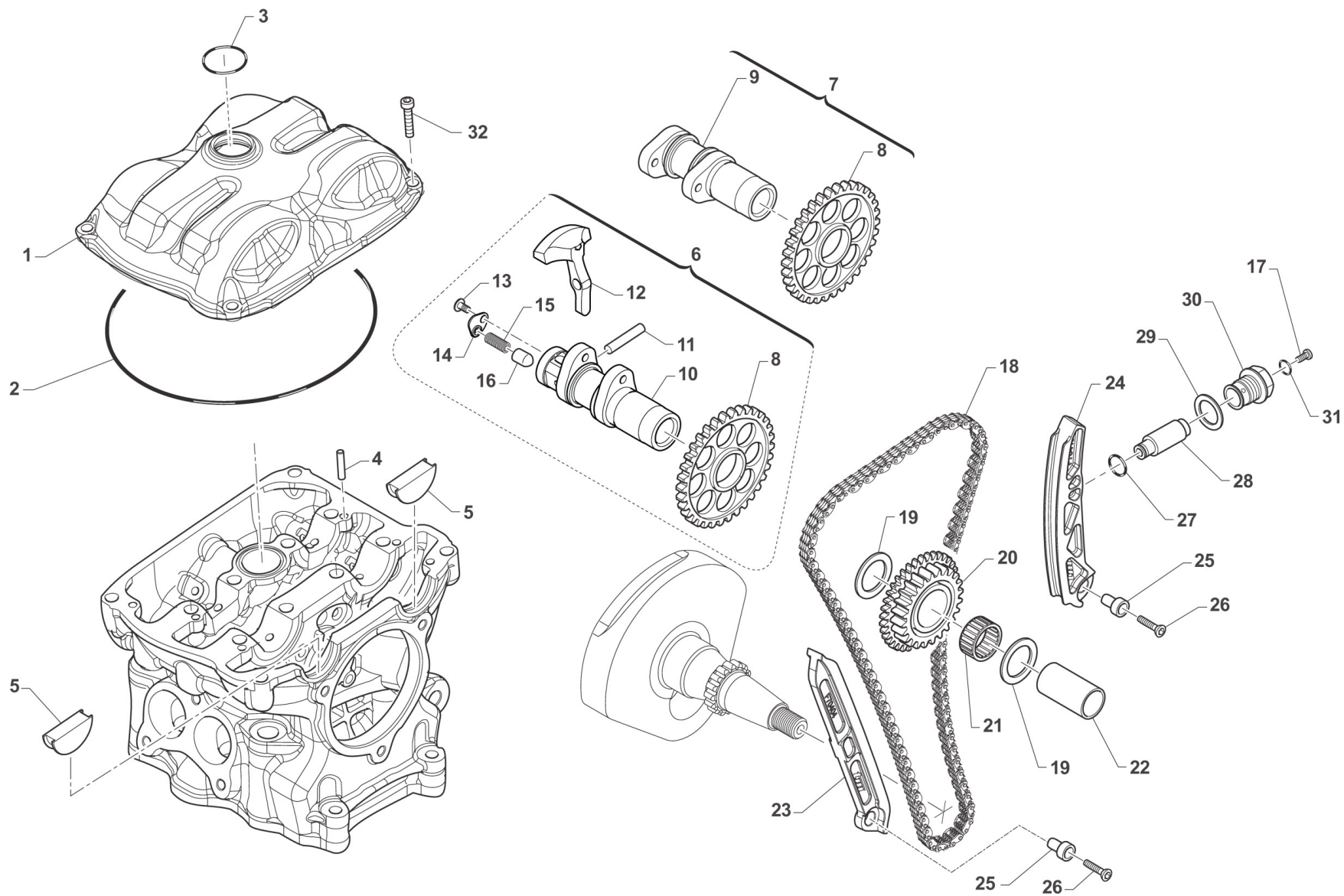

TM0004.01



4T300FIEN26-M
4T 300 Fi EN - 4S 300 Fi EN

DISTRIBUZIONE
DISTRIBUTION

4

Pos.	Codice	Q.tà	Note	Descrizione	Description
1	F30061	1		COPERCHIO TESTA 250Fi MX MY18	CYLINDER HEAD COVER 250Fi F.S. MX M18->
2	F12364	1		O RING 155X2	O-RING 155 X 2
3	F12345.1	1		O RING ORM 24,0X1,5 VITON	O-RING 24 X 1,5
4	F19529	4		RULLO D.4 X 10 TESTA BOMBATA" NRA"	PIN 4 X 10
5	F30060	2		COPERC.TTO FORI A.CAMME250/300	CAP, HOLE CAMSHAFT 250/300
6	F28852	1		ALBERO A CAMME SCARICO XS-04 250Fi MX ES + EN CPL	CAMSHAFT ASSY, EX, 250 MX ES + EN
7	F28853	1		ALBERO A CAMME ASPIRAZIONE 250-300 EN REPLICA CPL	CAMSHAFT ASSY, IN, 250/300 EN TWIN
8	F40062	2		INGR. ALBERO A CAMME GEN. Z28	GEAR 28T, CAMSHAFT
9	F28808	1		ALBERO A CAMME ASP. EVO3 XA-19	CAMSHAFT IN XA-19
10	F28809	1		ALBERO A CAMME SCAR.EVO3 XS-04	CAMSHAFT EX XS-04
11	F19530	1		RULLO D.5 X 19.8 G2 0 -0.010	PIN 5 X 19,8
12	F26575	1		DECOMPRESSORE (MASSA CENT.) 4T 250/300 TWIN	DECOMPRESSOR
13	49597	1		VITE TBCEI 4 x 8 UNI 7380	BOLT TBCE 4 x 8
14	F48368	1		PIASTRINO GUIDA MOLLA DECOMPR.	PLATE DECOMPRESSOR SPRING 250 F.S.
15	F16479	1		MOLLA DECOMP. FILO Ø 0,3 250/300 4T TWIN	SPRING
16	F26576	1		PISTONCINO ATTIVAZIONE DECOMP.	PISTON DECOMPRESSOR
17	F49871	1		TAPPO ASSE ROT.BILANC.250 M3	PLUG
18	F70423	1		CATENA DIST.MORSE 92RH2015 92P 300 TWIN	CAM CHAIN 92RH2015 92 300 TWIN
19	F48372	2		RASAMENTO 18 x 30 x 0.8	SHIM 18 X 30 X 0,8
20	F40061	1		INGR. DOPPIO DISTRIBUZ.24/21	GEAR 24/21T DISTRIBUTION
21	F19526	1		GABBIA A RULLINI K 18X22X17	NEEDLE BUSH 18x22x17
22	F28813	1		ASSE ROTAZIONE INTR.18X42,7F13	PIN ROTATION GEAR 18x42,7 H.13
23	F70404	1		PATTINO FISSO 4T 250/300 TWIN	FIXED SLIDER
24	F70413	1		PATTINO MOBILE 4T 250/300 TWIN	MOVING SLIDER
25	F49883	2		BOCCOLA FISS. PATT.MOB. F70402	BUSH
26	49168	2		VITE TSEI 6X22	
27	F12346.1	1		O RING ORM 18,0X2,0 VITON	O-RING 18 X 2



4T300FIEN26-M
4T 300 Fi EN - 4S 300 Fi EN

DISTRIBUZIONE
DISTRIBUTION

4

Pos.	Codice	Q.tà	Note	Descrizione	Description
28	F70408	1		TENDITORE IDRAULICO 250 M3 F-346264.89-0100.KSH.KSYS	HYDRAULIC TENSIONER 250Fi M3
29	49949	1		RONDELLA RAME 24X30X1,5	WASHER, COPPER, 24 X 30 X 1,5
30	F49884	1		TAPPO TENSIONATORE IDR. M3	PLUG, TENSIONER
31	F12356.1	1		O RING ORM 10,0X1,0 VITON	O-RING 10 X 1
32	49483	4		VITE TCEI 6X16 UNI 5931	BOLT TCEI 6X16



4T300FIEN26-M
4T 300 Fi EN - 4S 300 Fi EN

LUBRIFICAZIONE
LUBRICATION

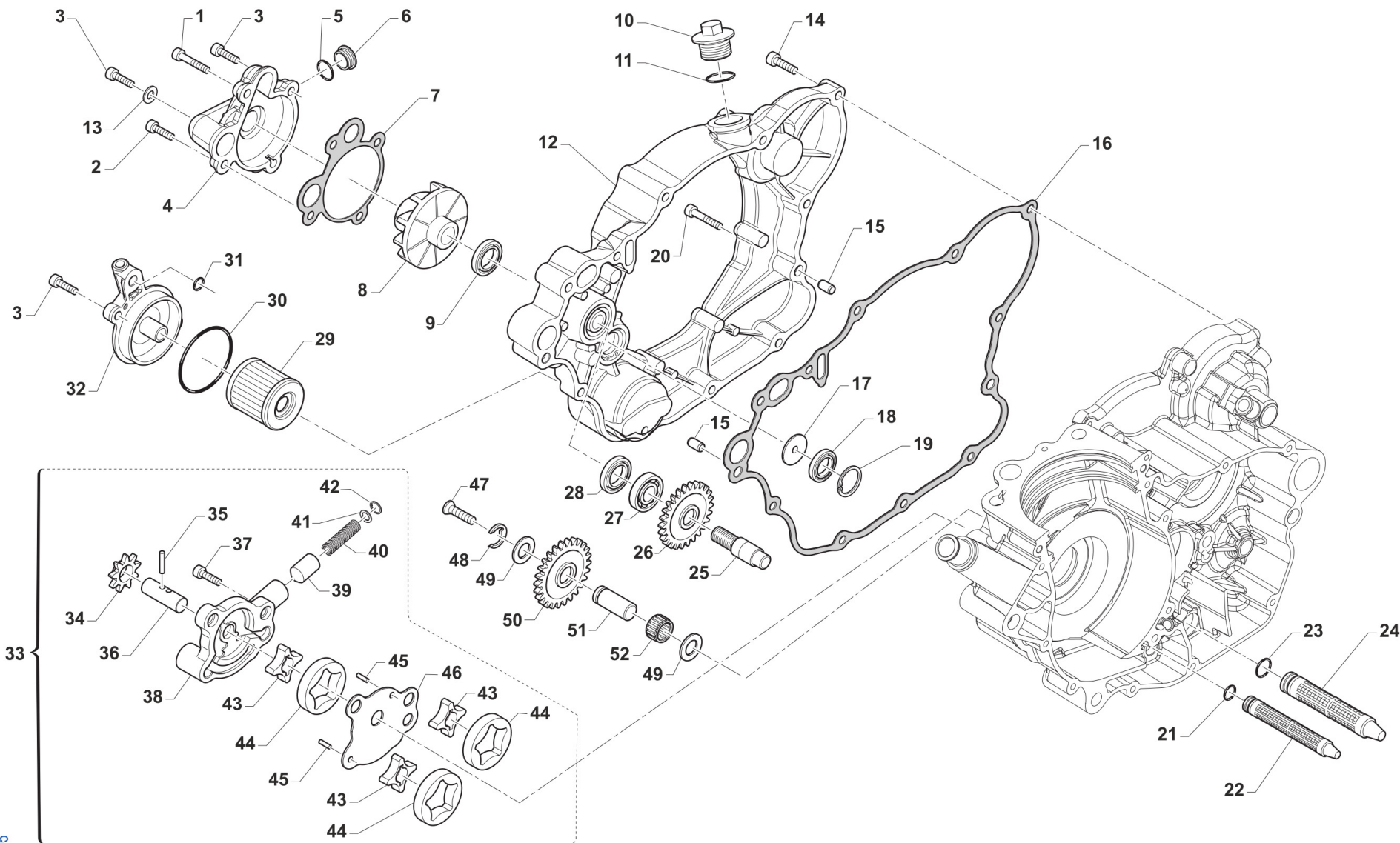

TM0005



4T300FIEN26-M
4T 300 Fi EN - 4S 300 Fi EN

LUBRIFICAZIONE
LUBRICATION

5

Pos.	Codice	Q.tà	Note	Descrizione	Description
1	49575	1		VITE TCEI 5X45 UNI 5931	BOLT TCEI 5X45
2	49570	1		VITE TCEI 5X50 UNI 5931	SCREW TCEI 5X50
3	49476	3		VITE TCEI 5X20 UNI 5931-912	BOLT TCEI 5X20
4	F30966	1		COPERCHIO POMPA H2O 250Fi 11/-	COVER, WATER PUMP 250Fi M.2011
5	F12327	1		O RING COPERCHIO P.ACQUA 250N	O-RING COVER WATER PUMP 250 4S
6	F49841	1		TAPPO COP. POMPA H2O 250Fi	CAP, COVER WATER PUMP 250 4S
7	F05833	1		GUARNIZ.COP.POMPA ACQUA.250N	GASKET, H2O COVER 250Fi
8	F28679	1		GIRANTE POMPA ACQUA 250N	IMPELLER, H2O PUMP 250Fi
9	04017	1		PARAOLIO CENTRIFUGA 06	OIL SEAL 8 X 22 X 7 TC
10	F49925	1		TAPPO CARICO OLIO M20X1.5	OIL PLUG M20X1,5
11	F49920	1		RONDELLA ALL 20.4X26X1.5	WASHER 20,4X26X1,5 ALUM.
12	F30961	1		COPERCHIO TRAS. PRIM. 250N '11	COVER, PRIMARY DRIVE 250N 11->
13	49119	1		RONDELLA 5 x 9 x 1,5 ALLUMINIO	WASHER, 5 x 9 x 1.5 ALLUMINIUM
14	49477	7		VITE TCEI 5X25 UNI 5931-912	BOLT TCEI 5X25
15	26041	2		GRANO CENTRAGGIO D.7X8 F.5,2	DOWEL PIN 7 x 8 Hole 5,2
16	F05828	1		GUARNIZ.COP.TRASM.PRIMAR.250N	GASKET, CLUTCH CASE 250Fi
17	F32529	1		DISCHETTO PARZIAL. MAND.OLIO 250N	DISC OIL PUMP 250 F.S.
18	F04390	1		PARAOLIO FAJ 14-22-5 HS	OIL SEAL FAJ 14-22-5 HS
19	F49913	1		SEEGER I 23	CIRCLIP INT. 23
20	49478	1		VITE TCEI 5X30 UNI 5931	BOLT TCEI 5X30
21	F12325	1		OR ORM 090-15 FILTRO ASP.OLIO 250N	O-RING
22	F32532	1		FILTRO ASPIRAZ.POMPE OLIO 250N	FILTER, OIL, 250Fi
23	F12343	1		O RING FILTRO OLIO 250F	O-RING
24	F32555	1		FILTRO ASPIRAZIONE OLIO MAGG.	FILTER OIL INLET
25	F28658	1		ALBERINO POMPA H2O 250N	SHAFT, WATER PUMP 250Fi
26	F40112	1		INGRANAGGIO COND.P.ACQUA Z 21 300 4T	
27	F03365	1		CUSCINETTO POMPA ACQUA 250/09	BEARING WATER PUMP 250/09
28	F04363	1		PARAOLIO 8X22X5 250/09->	OIL SEAL 8x22x5 (250F/09)



4T300FIEN26-M
4T 300 Fi EN - 4S 300 Fi EN

LUBRIFICAZIONE
LUBRICATION

5

Pos.	Codice	Q.tà	Note	Descrizione	Description
29	F66510	1		FILTRO OLIO 4Tempi HF 141	OIL FILTER HF - 141
30	12094	1		O RING COP. FILTRO OLIO	O RING OIL FILTER COVER
31	F12302	1		O RING 108 PIOGGIA CAMBIO 4T	O-RING, 108 GEAR F.S.
32	F30965	1		COPERCHIO FILTRO OLIO 250Fi 11	CAP, OIL FILTER 250Fi 11->
33	F30068	1		POMPA OLIO COMPLETA 250/300 Fi TWIN	OIL PUMP ASSY
34	F40997	1		INGRANAGGIO POMPA OLIO 250Fi Z 9	GEAR, OIL PUMP 250Fi 9 T
35	F19513	3		RULLINO ING. POMPA 250/09	PIN, PUMP GEAR 250 09->
36	F28840	1		ALBERINO POM.OLIO RO.H10/2XH10	SHAFT, OIL PUMP
37	49751	2		VITE TCEI 5X22	BOLT TCEI 5 X 22
38	F30059	1		CORPO POMPA	OIL PUMP BODY
39	F32533	1		PIST.NE VALV.LIMIT.PRESS.OLIO	PISTON
40	F16441	1		MOLLA VALVOLA PRESS.OLIO 250N	SPRING
41	49600	1		RONDELLA 4x8x0,8	WASHER 4
42	49267	1		SEEGER 8mm INT Sp. 0,8	SEEGER
43	F32577	3		ROTORE INTERNO POMPA OLIO 250Fi	ROTOR, OIL PUMP, INTERNAL
44	F32578	3		ROTORE ESTERNO POMPA OLIO 250Fi	ROTOR, OIL PUMP, EXTERNAL
45	F19521	2		RULLINO D.3 X 11.8	PIN 3 X 11
46	F32574	1		SEPARATORE POMPA OLIO	PLATE
47	49429	1		VITE TSEI 4X35	BOLT TSEI 4X35
48	F49821	1		ANELLO ELASTICO RA 7 ING. FOLLE P.OLIO 250/09	SEEGER INTER.GEAR OIL P.250 4S
49	F19512	2		RALLA ING.FOLLE P. OLIO 250/09	THRUST WASHER
50	F40909	1		INGR. OZIOSO POMPA OLIO 250N	GEAR, OIL PUMP
51	F28665	1		ALBERINO ING.FOLLE P.OLIO 250N	SHAFT
52	F19511	1		GABBIA RULLI ING.F.P.OL.250/09	NEEDLE CAGE GEAR 250F 09->



4T300FIEN26-M
4T 300 Fi EN - 4S 300 Fi EN

CARTER MOTORE
CLUTCH CASE

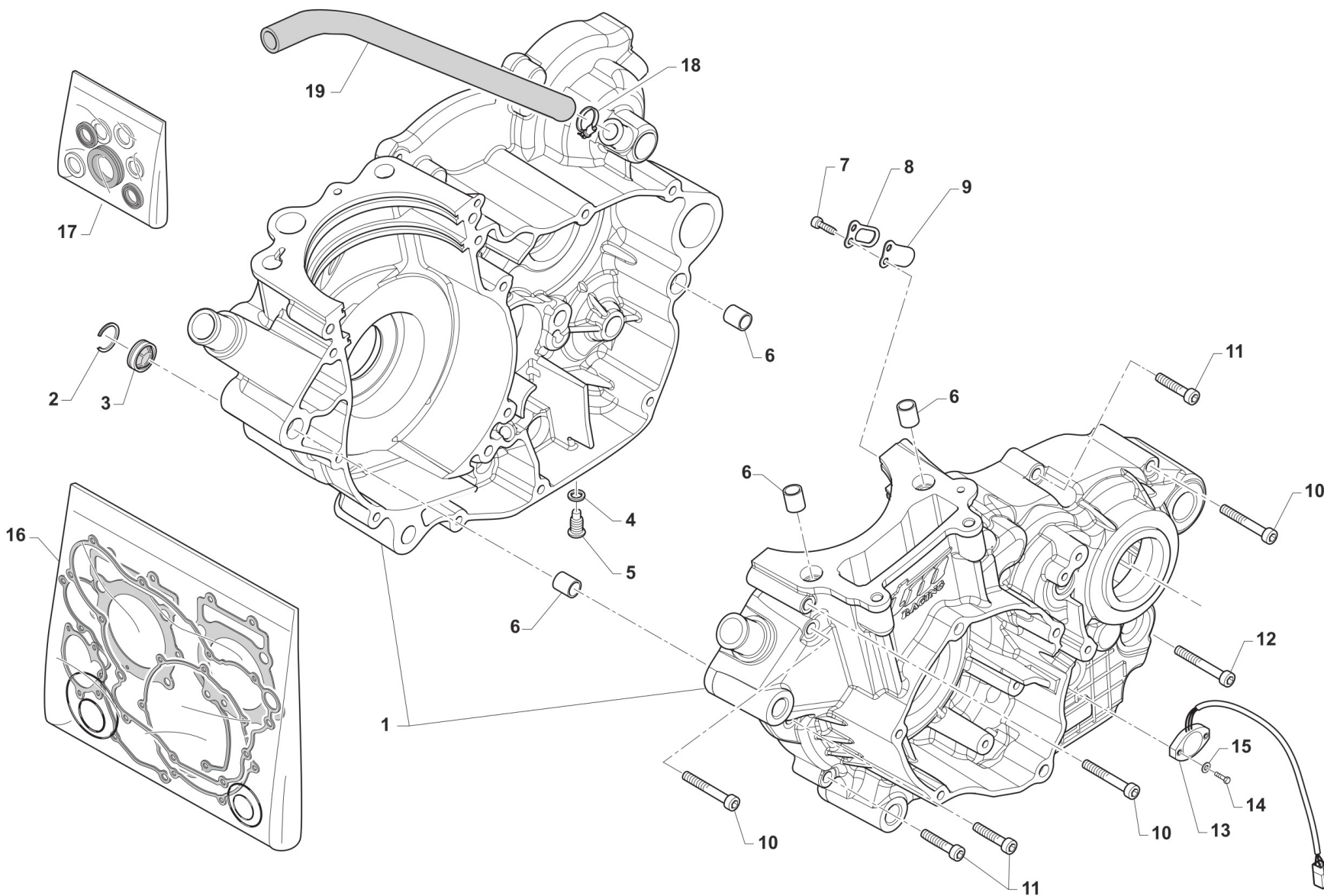

TM 0006.01



4T300FIEN26-M
4T 300 Fi EN - 4S 300 Fi EN

CARTER MOTORE
CLUTCH CASE

6

Pos.	Codice	Q.tà	Note	Descrizione	Description
1	F30076.1	1		BASAMENTO MOT. 300Fi ES MY26PER INGR. DOPPIO AVV. MAGGIORATO	
2	F49832	1		SEEGER SB25 OBLO' 250Fi 10/->	SEEGER
3	F04366	1		OBLO' LIVELLO OLIO DIAM.25 MM	OIL LEVEL INSPECTION SIGHT GLASS
4	49125.1	2		RONDELLA RAME 12X18X1,5	
5	F49820.1	2		TAPPO OLIO C/CALAM. 250Fi	OIL PLUG WITH MAGNET 250Fi
6	F26428	4		GRANO RIFERIMENTO 12X13 F10.2	GRUB SCREW 12X13 H.10,2mm
7	49542	1		VITE TCEI 5X10 UNI 5931	BOLT TCEI 5 X 10
8	F20004	1		STOPPER LAMELL.CAMERA ALB.250N	STOPPER, STOP
9	F20003	1		LAMELLA SFIATO PRESS.250Fi	REED
10	49491	3		VITE TCEI 6X55	BOLT TCEI 6X55
11	49487	4		VITE TCEI 6X35 UNI 5931	BOLT TCEI 6X35
12	49492	1		VITE TCEI 6X60	BOLT TCEI 6X60
13	F08456	1		SENSORE POSIZIONE CAMBIO eM060 CPL G.ORARIO (SOSTITUISCE F08236.1)	
14	49922	2		VITE TE 3X14	
15	49926	2		RONDELLA 3X9X1	WASHER 3 X 9 X 1
16	F05864	1		KIT GUARNIZIONI 300Fi EN/MX MY20 REPLICA	GASKETS 300FI EN7MX MY20->
17	04043	1		KIT PARAOLI 4T 250/300Fi TWIN MY2022	
18	51073	1		FASCETTA 10/19	CLAMP 10 / 19 mm
19	F65104	1		TUBO COPOLAN GRIGIO 11x16	HOSE COPOLAN GREY 11X16mm

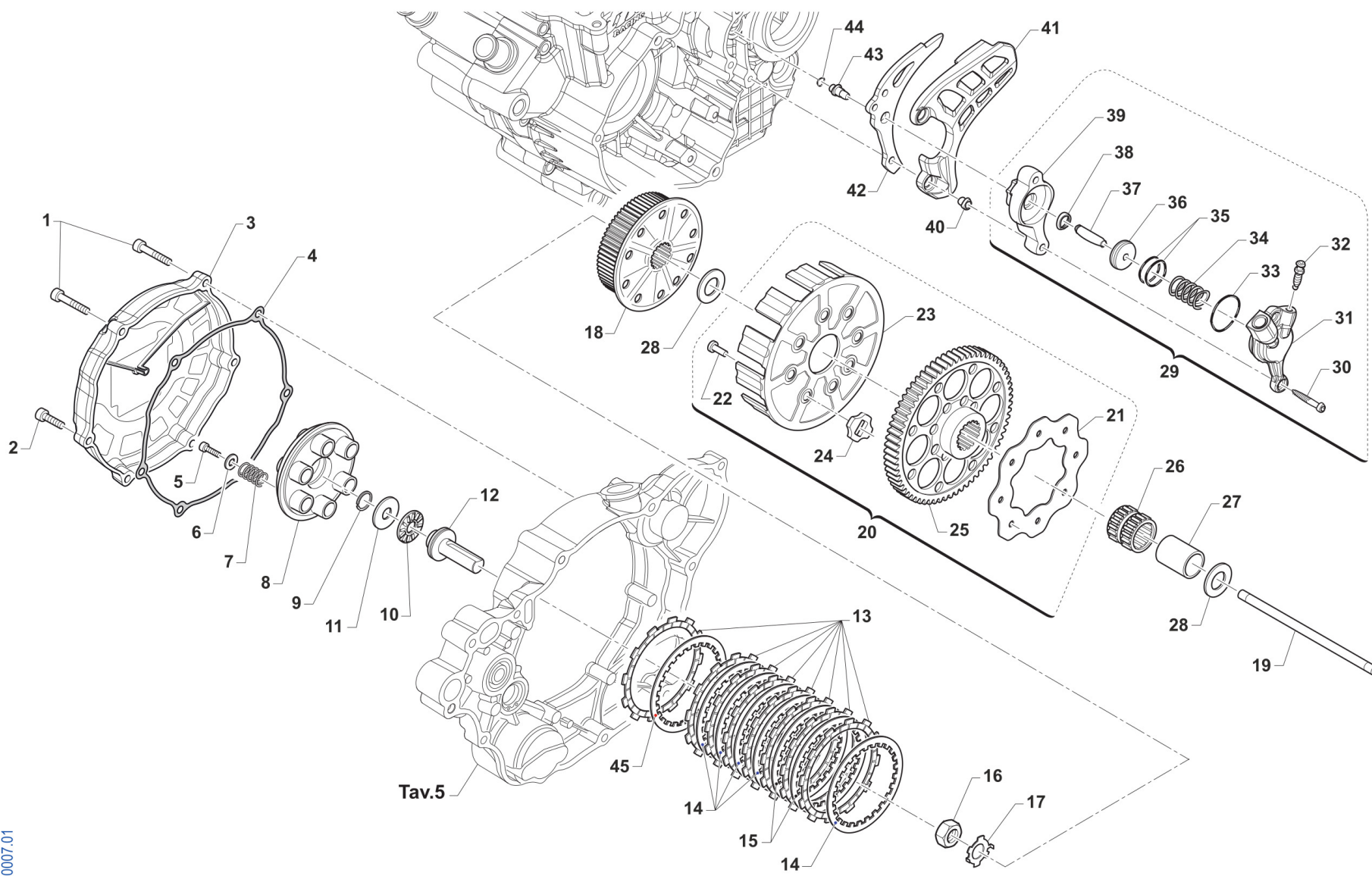

TM 0007.01



4T300FIEN26-M
4T 300 Fi EN - 4S 300 Fi EN

FRIZIONE
CLUTCH

7

Pos.	Codice	Q.tà	Note	Descrizione	Description
1	49736	2		VITE TCEI 5X65	BOLT TCEI 5X65
2	49477	4		VITE TCEI 5X25 UNI 5931-912	BOLT TCEI 5X25
3	F30960	1		COPERCHIETTO FRIZ.250Fi M.11->	COVER, CLUTCH 250Fi M. 11/->
4	F05841	1		GUARN. COP. FRIZ. 250Fi 2011	GASKET, CLUTCH COV 250Fi 11/->
5	49484	6		VITE TCEI 6X20	BOLT TCEI 6X20
6	49604	6		RONDELLA 6 X18 X 1,6	WASHER 6x18
7	F16453	6		MOLLA FRIZIONE 2/4T 250/450	SPRING, CLUTCH 2/4T 250/450
8	F25258	1		PIATTO SPINGIDISCHI 250Fi	PRESSURE PLATE, CLUTCH 250Fi
9	09006	1		ANELLINO FERMA SPINOTTO 80/85/100	CLIP, PISTON PIN 80/85/100cc
10	19022	1		GABBIA A RULLI RAD. AXK 1528	BUSH CAGE AXK 1528, RADIAL
11	19023	1		RONDELLA GABBIA RULLI AS 1528	WASHER, NEEDLE CAGE AS 1528
12	F35582	1		FUNGO FRIZIONE IDRAULICA 2015	PIECE, CLUTCH LIFTER
13	F35588	8		DISCO FRIZIONE 4T 250/300 Fi FCC	CLUTCH PLATE, FIBER 250Fi 4S
14	35070	5		DISCO FRIZ. ACC 1,2 mm 4T 250/300 C67	
15	F35596	2		DISCO FRIZ. ACC 1,8 mm 250Fi	CLUTCH DISC STEEL 1,8 mm 250Fi
16	49060	1		DADO TAMBUR.FRIZ. ALB.PRIM. 250/300 M18X1.5	NUT, CLUTCH CENTER 250cc
17	35050	1		RONDELLA X FRIZ. 250/300/4T	CLUCTH WASHER 250/300/F
18	F25256	1		TAMBURELLO FRIZ. 4T 250/300 Fi	CLUTCH CENTER 4S 250/300 Fi
19	F35544	1		ASTINA CENTRAL.FRIZ.192mm 250N	ROD, CLUTCH 192mm 250N
20	F40159	1		COPPIA PRIMARIA CPL 300Fi Z 59/18	
21	35262	1		DISCO BATTUTA GOMMINI FRIZ. 2T/4T F.6 MM	PLATE, CLUTCH BASKET 250cc
22	49202	8		CHiodo CAMPANA FRIZIONE D. 5,8	PIN CLUTCH K3/KV/K7/K8/K9
23	F25257	1		CAMPANA FRIZ. 250Fi	CLUTCH BASKET 250Fi M. 10/->
24	21005	8		GOMMINO PARASTRAPPI FRIZIONE	RUBBER, CLUTCH BASKET
25	F40114	1		CORONA TRAS.PRIMARIA Z 59/18 300 4T	
26	F19510	1		GABBIA A RULLINI K 27X32X23.8	NEEDLE CAGE 27 x 32 x 23.8
27	F26422	1		BOCCOLA INGR.TRASM.PRIM. 250N	BUSH, PRIMARY GEAR 250Fi
28	48250	2		SPESSORE COPPIA PRIMARIA 250	SPACER, PRIMARY GEAR 250cc



4T300FIEN26-M
4T 300 Fi EN - 4S 300 Fi EN

FRIZIONE
CLUTCH

7

Pos.	Codice	Q.tà	Note	Descrizione	Description
29	F30005	1		COP. FRIZ/IDR 4T 250N D.26 CPL	COVER, IDR/CLUTCH 4S 250N ASSY
30	49535	2		VITE TCEI 5X35 UNI 5931-912	BOLT TCEI 5X35
31	F30006	1		CORPO CILIN. FRIZ. 250Fi D.26	BODY CLUTCH CYLINDER 250Fi D26
32	35264	1		VITE SPURGO OLIO FRIZ.IDR.6X1	SCREW AIR BLEED HYDRAUL.CLUTCH
33	12252	1		O RING PIGNONE CAT.+DIS.AL.MOT	O-RING, 25,12 x 1,78
34	F16445	1		MOLLA PIST. FRIZ. 250N	SPRING
35	12259	2		O RING PISTONE FR.125/250 VITON (Verde)	O-RING, CLUTCH PISTON 125/250
36	F35522	1		PISTONE CILINDRETTO 250N D.26	PISTON CLUTCH CYLINDER 250F 26
37	F19518	1		RULLO D.S. 5 X 24	PIN 5 X 24
38	F04367	1		PARAOLIO 9X13X3	OIL SEAL 9X13X3
39	F35523	1		DISTANZIALE CILINDRETTO 250N	SPACER CYLINDER 250N
40	26211	2		BOCCOLA PROT. PIGNONE 250 F.5	COLLAR, SPROCKET 250cc H.5
41	F30944	1		PROTEZIONE PIGNONE 250Fi PLAST	SPROCKET PROTECTION 250 F.I. PLAST.
42	F70370	1		PROTEZ. ERGAL PIGN. CAT 250N	PROTECTION, ALUMINIUM, FRONT SPROCKET
43	F26460	1		DIST.CENTR.SUPP.ATT.FRIZ.250N	SPACER
44	F12302	1		O RING 108 PIOGGIA CAMBIO 4T	O-RING, 108 GEAR F.S.
45	F35541	2		DISCO FRIZ. ACC 1,5 mm 250N	CLUTCH PLATE, STEEL 1,5 250Fi



4T300FIEN26-M
4T 300 Fi EN - 4S 300 Fi EN

FRIZIONE (OPEN CLUTCH F1)

OPEN
CLUTCH

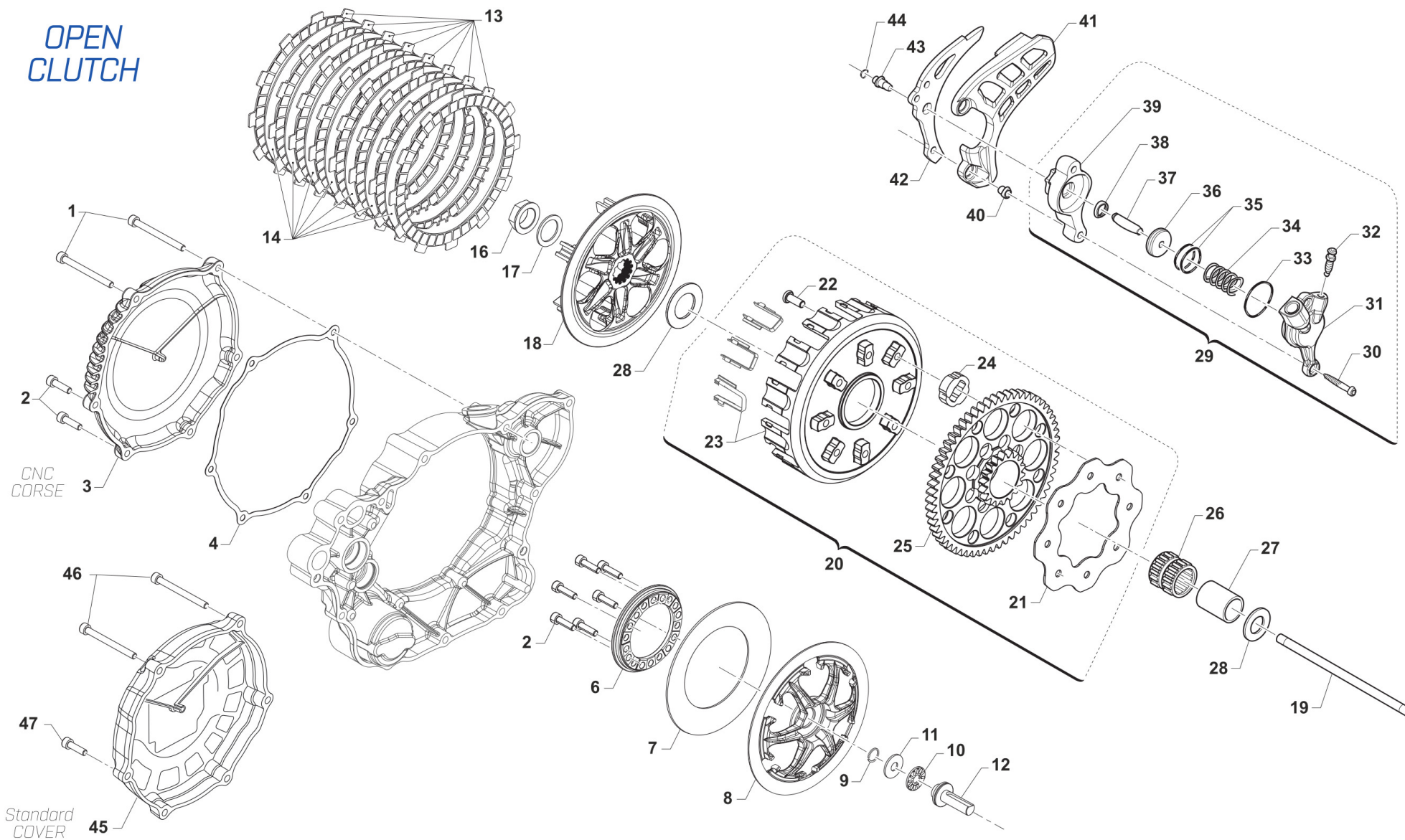



4T300FIEN26-M
4T 300 Fi EN - 4S 300 Fi EN

FRIZIONE (OPEN CLUTCH F1)

8

Pos.	Codice	Q.tà	Note	Descrizione	Description
1	49578	1		VITE TCEI 5X55	BOLT TCEI 5X55
2	49475	10		VITE TCEI 5X18	BOLT TCEI 5X18
3	30400A	1		COPERCHIO FRIZIONE F1BX- CNC TM CORSE	
4	F05841	1		GUARN. COP. FRIZ. 250Fi 2011	GASKET, CLUTCH COV 250Fi 11/->
6	25019	1		ELEMENTO FISSAGGIO MOLLA	
7	16082	1		MOLLA FRIZIONE 114,8x71x1,55x4,60	
8	25024	1		TAMBURELLO FRIZIONE F1BBN	
9	09006	1		ANELLINO FERMA SPINOTTO 80/85/100	CLIP, PISTON PIN 80/85/100cc
10	19022	1		GABBIA A RULLI RAD. AXK 1528	BUSH CAGE AXK 1528, RADIAL
11	19023	1		RONDELLA GABBIA RULLI AS 1528	WASHER, NEEDLE CAGE AS 1528
12	F35582	1		FUNGO FRIZIONE IDRAULICA 2015	PIECE, CLUTCH LIFTER
13	35080	8		DISCO FRIZIONE CONDUTTORE D.131.4 - d.110.6 - s.2	
14	35078	7		DISCO FRIZIONE CONDOTTO D. 132 SP. 1.2	
16	F49816B	1		DADO Ø27.5 - M18 x 1,25	
17	490059	1		RONDELLA SCHNORR DIN9250 - M18/19x27x1.5	
18	25020	1		SPINGIDISCO FRIZIONE F1XXN	
19	35082	1		ASTINA FRIZIONE 4T 250/300 176,2 F1BB	
20	40574	1		COPPIA PRIMARIA CPL 4T 300Fi EN/MX Z 59/18 (OPEN CLUTCH F1)	
21	35262	1		DISCO BATTUTA GOMMINI FRIZ. 2T/4T F.6 MM	PLATE, CLUTCH BASKET 250cc
22	49202	8		CHiodo CAMPANA FRIZIONE D. 5,8	PIN CLUTCH K3/KV/K7/K8/K9
23	25009	1		CAMPANA FRIZIONE 250/300 4T PER PACCO DISCHI ACCIAIO	
24	21005	8		GOMMINO PARASTRAPPI FRIZIONE	RUBBER, CLUTCH BASKET
25	F40114	1		CORONA TRAS.PRIMARIA Z 59/18 300 4T	
26	F19510	1		GABBIA A RULLINI K 27X32X23.8	NEEDLE CAGE 27 x 32 x 23.8
27	F26422	1		BOCCOLA INGR.TRASM.PRIM. 250N	BUSH, PRIMARY GEAR 250Fi
28	48250	2		SPESSORE COPPIA PRIMARIA 250	SPACER, PRIMARY GEAR 250cc



4T300FIEN26-M
4T 300 Fi EN - 4S 300 Fi EN

FRIZIONE (OPEN CLUTCH F1)

8

Pos.	Codice	Q.tà	Note	Descrizione	Description
29	F30005	1		COP. FRIZ/IDR 4T 250N D.26 CPL	COVER, IDR/CLUTCH 4S 250N ASSY
30	49535	2		VITE TCEI 5X35 UNI 5931-912	BOLT TCEI 5X35
31	F30006	1		CORPO CILIN. FRIZ. 250Fi D.26	BODY CLUTCH CYLINDER 250Fi D26
32	35264	1		VITE SPURGO OLIO FRIZ.IDR.6X1	SCREW AIR BLEED HYDRAUL.CLUTCH
33	12252	1		O RING PIGNONE CAT.+DIS.AL.MOT	O-RING, 25,12 x 1,78
34	F16445	1		MOLLA PIST. FRIZ. 250N	SPRING
35	12259.1	2		O RING 2087 (21,95x1,78) MARRONE	
36	F35522	1		PISTONE CILINDRETTO 250N D.26	PISTON CLUTCH CYLINDER 250F 26
37	F19518	1		RULLO D.S. 5 X 24	PIN 5 X 24
38	F04367	1		PARAOLIO 9X13X3	OIL SEAL 9X13X3
39	F35523	1		DISTANZIALE CILINDRETTO 250N	SPACER CYLINDER 250N
40	26211	2		BOCCOLA PROT. PIGNONE 250 F.5	COLLAR, SPROCKET 250cc H.5
41	F30944	1		PROTEZIONE PIGNONE 250Fi PLAST	SPROCKET PROTECTION 250 F.I. PLAST.
42	F70370	1		PROTEZ. ERGAL PIGN. CAT 250N	PROTECTION, ALUMINIUM, FRONT SPROCKET
43	F26460	1		DIST.CENTR.SUPP.ATT.FRIZ.250N	SPACER
44	F12302	1		O RING 108 PIOGGIA CAMBIO 4T	O-RING, 108 GEAR F.S.
45	30403	1		COPERCHIO FRIZIONE 4T 250/300Fi (OPEN CLUTCH F1) - STD	
46	49579	2		VITE TCEI 5X60	
47	49476	4		VITE TCEI 5X20 UNI 5931-912	BOLT TCEI 5X20



4T300FIEN26-M
4T 300 Fi EN - 4S 300 Fi EN

COMANDO CAMBIO
GEARSHIFT MECHANISM

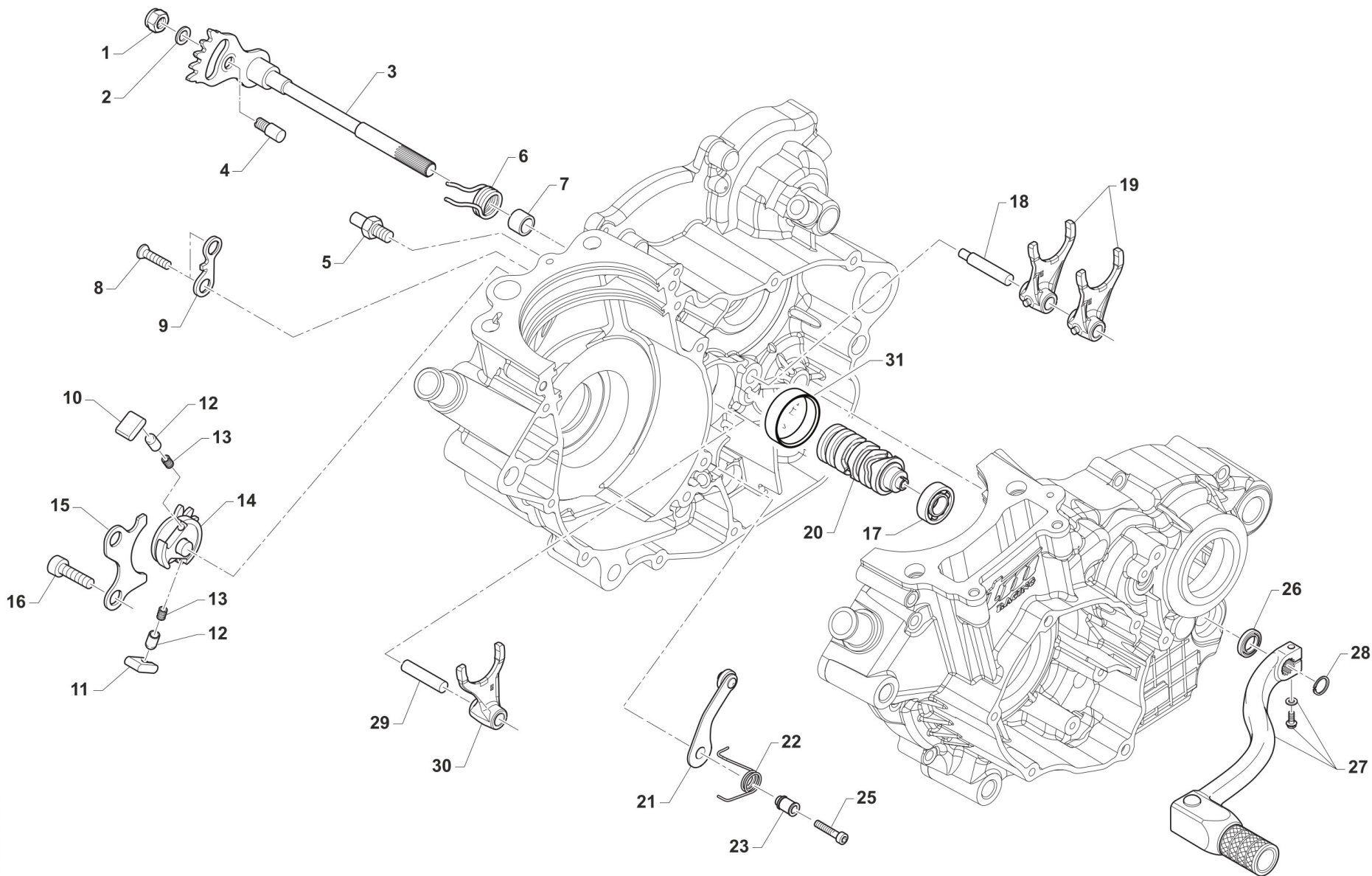

TM 0008.01



4T300FIEN26-M
4T 300 Fi EN - 4S 300 Fi EN

COMANDO CAMBIO
GEARSHIFT MECHANISM

9

Pos.	Codice	Q.tà	Note	Descrizione	Description
1	49638	1		DADO M 6 ALTO AUTOBLOCCANTE	NUT 6mm, HIGHT SELF-LOCKING
2	49603	1		RONDELLA M 6,4 X 12 X 1,6	WASHER 6x12
3	28100	1		ALBERO COMANDO ING. P.TACRIC.	SHAFT, GEARSHIFT
4	26050	1		BATTUTA ECCENTRICA	ADJUSTER SELECTOR SHAFT
5	F26455	1		BATTUTA FISSA MAN.CAMBIO 250N	
6	16010	1		MOLLA RITORNO LEVA CAMBIO 3	SPRING, RETURN GEAR LEVER 3mm
7	26006	1		DISTANZIALE MOLLA LEVA CAMBIO	SPACER, GEAR LEVER SPRING
8	49404U	2		VITE TSEI 6X16 UMBRAKO	BOLT TSEI 6X16 UMBR.
9	F26454	1		PIASTR.FINECORSO CRIC. 250N	PLATE, ENDSTROKE RATCHET 250N
10	26060	1		CRICCHETTO CAMBIO SUPERIORE	RATCHET UP, GEAR
11	26061	1		CRICCHETTO CAMBIO INFERIORE	RATCHET DOWN, GEAR
12	26062	2		PUNTALE PER CRICCHETTO CAMBIO	PIN, RATCHET GEAR
13	16012	2		MOLLA PER PUNTALE	SPRING, GEARBOX PIN
14	40310	1		INGRANAGGIO PORTACRICCHETTI	DRUM SHIFTER GEAR
15	26021	1		PIASTRINO RIENTRO CRICCHETTI	PLATE, RATCHET
16	49483	2		VITE TCEI 6X16 UNI 5931	BOLT TCEI 6X16
17	03012	1		CUSCINETTO DESMODROMICO 6001 2RS	BUSH, 6001 2RS GEAR DRUM
18	33256	1		PERNO FORCH.ALB.SEC. 250 / 125.99	AXEL, COUNTERSHAFT FORK 250cc
19	F33312	2		FORCHETTA A/S 250Fi CROMATA	SHIFT FORK COUNTERSHAFT 250 4S
20	F33353.1	1	PER CAMBIO 6M	DESMODROMICO 250-300 4T 6M. PR.4	
21	26095	1		PIASTRINO BLOCCAMARCE KV/95CPL + MOTO	PLATE, STOP GEAR KV/95 ASSY
22	F16447.3	1		MOLLA BLOCCA MARCE 250 4T D.FILO 2.4	
23	26007	1		DISTANZIALE MOLLA BLOCCAMARCE	SPACER, STOP GEAR SPRING
25	49485	1		VITE TCEI 6X25 UNI 5931	BOLT TCEI 6x25
26	04004	1		PARAOLIO POMPA H2O-LEVA CAMBIO	OIL SEAL 12 x 22 x 5
27	43050	1		LEVA CAMBIO 4T MY22 [587]	GEAR LEVER 4S (587)
28	49212	1		SEEGER E12 LEVA CAMBIO	CIRCLIP D.12 - EXTERNAL
29	33255	1		PERNO FORCH.ALB. PRIM.250 / 125.99	AXEL, MAINSHAFT FORK 250cc



4T300FIEN26-M
4T 300 Fi EN - 4S 300 Fi EN

COMANDO CAMBIO
GEARSHIFT MECHANISM

9

Pos.	Codice	Q.tà	Note	Descrizione	Description
30	F33311	1		FORCHETTA A/P 250Fi CROMATA	FORK, MAIN SHAFT 250Fi
31	19041	1		ASTUCCIO A RULLI HK 35/12	BUSH NEEDLE CAGE DHK 35/12



4T300FIEN26-M
4T 300 Fi EN - 4S 300 Fi EN

CAMBIO 6M 4T 300
GEAR BOX 4S 300

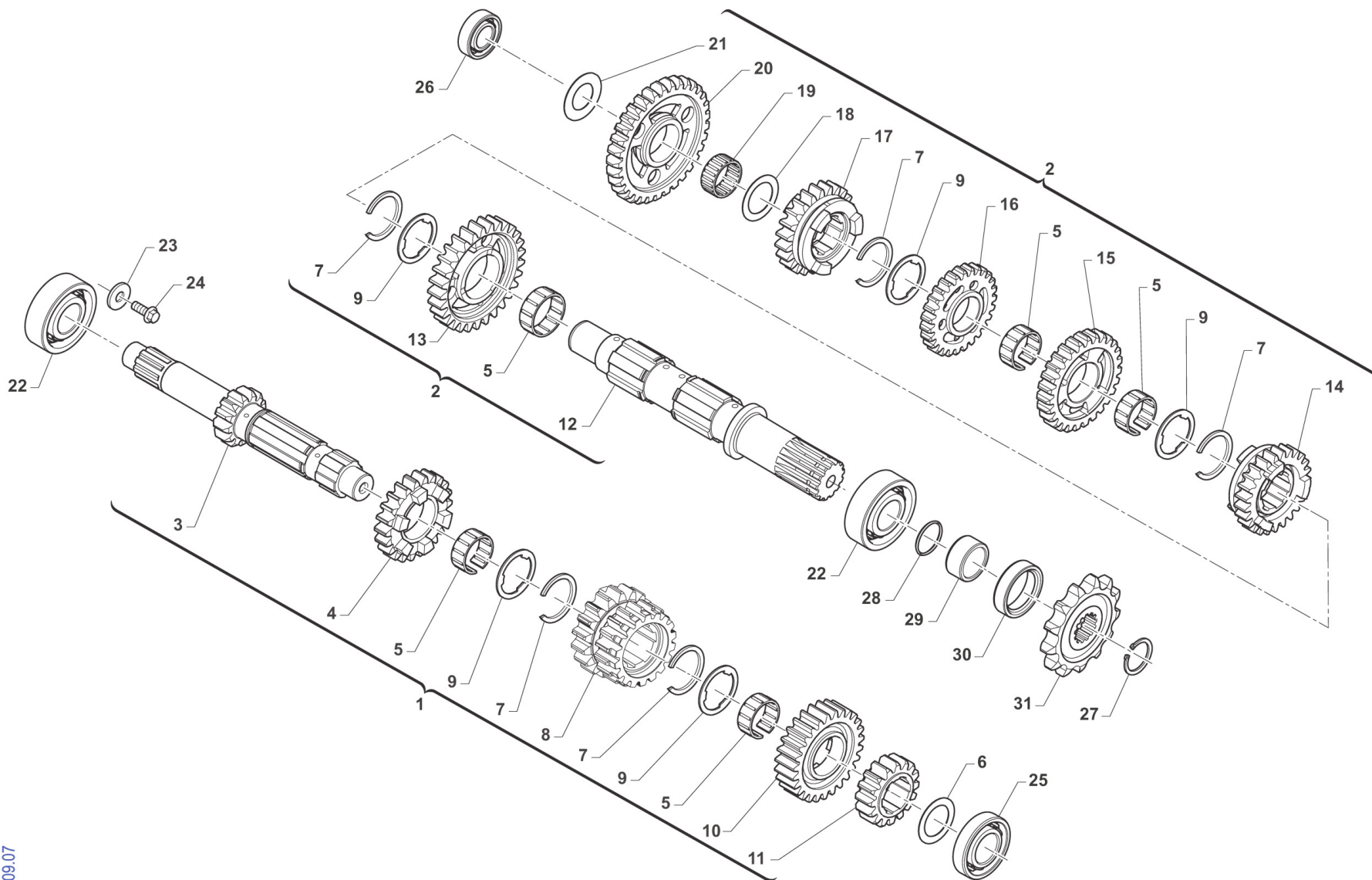

TM0009.07



4T300FIEN26-M
4T 300 Fi EN - 4S 300 Fi EN

CAMBIO 6M 4T 300
GEAR BOX 4S 300

10

Pos.	Codice	Q.tà	Note	Descrizione	Description
1	F40240	1		ALBERO PRIMARIO 300Fi MX 23 4T (6 ALETTE) CPL	
2	F40241	1		ALBERO SECONDARIO 300Fi MX 23 4T (6 ALETTE) CPL	
3	F40215	1		ALBERO PRIMARIO Z 13 6 ALETTE 300 4T	
4	F40218	1		INGRANAGGIO 5a A.P. Z20 6 ALETTE 300 4T	
5	F19524	5		GABBIA A RULLI 22X26X10 TAGL.	NEEDLE BEARING 22 X 26 X 10
6	48253	1		SPESSORE CAMBIO 17X30X1 250	SPACER, GEAR BOX 250cc 17X30X1
7	F49869	5		SEEGER SW 24 (EST.) "SEEGER"	CIRCLIP SW 24 (EXTERNAL)
8	F40217	1		INGRANAGGIO 3/4a A.P.Z16/20 6 ALETTE 300 4T	
9	48258	5		SPESSORE DENT.CAMBIO INT.55 6M	SPACER GEAR INT.55 6S
10	F40219	1		INGRANAGGIO 6a A.P. Z22 6 ALETTE 300 4T	
11	F40216	1		INGRANAGGIO 2a A.P. Z15 6 ALETTE 300 4T	
12	F40220	1		ALBERO SECONDARIO 6 ALETTE 250/300 4T	
13	F40222	1		INGRANAGGIO 2a A.S. Z27 6 ALETTE 300 4T	
14	F40226	1		INGRANAGGIO 6a A.S. Z20 6 ALETTE 300 4T	
15	F40223	1		INGRANAGGIO 3a A.S. Z 23 6 ALETTE 300 4T	
16	F40224	1		INGRANAGGIO 4a A.S. Z 24 6 ALETTE 300 4T	
17	F40225	1		INGRANAGGIO 5a A.S. Z21 6 ALETTE 300 4T	
18	F48353	1		SPESSORE PS 18X25X1	SPACER 18x25x1
19	F19514	1		GABBIA A RULLI 18X22X10	NEEDLE CAGE 18X22X10
20	F40221	1		INGRANAGGIO 1a A.S. Z31 6 ALETTE 300 4T	
21	48012	1		RASAMENTO A/S M/M SPESS.0,5	SPACER, 26x17x0,5
22	F03368	2		CUSCINETTO 62/22 C3 22x50x14	BEARING 62/22 C3 22x50x14
23	49603	1		RONDELLA M 6,4 X 12 X 1,6	WASHER 6x12
24	49480	1		VITE TCEI 6X10 UNI 5931	BOLT TCEI 6X10
25	03254	1		CUSCINETTO A.P.4 Tempi 2RS1/C3	BUSH, MAINSHAFT 2RS/C3 4S
26	F03367	1		CUSCINETTO 6003 TN9C3 17x35x10	BUSH, 6003 TN9 C3 17x35x10
27	49217	1		SEEGER E22 ANELLO ALB/S	CIRCLIP D.22 - COUNTERSHAFT
28	F12320	1		O RING BOCCOLA PIGNONE 250/09	O-RING NBR 2087



4T300FIEN26-M
4T 300 Fi EN - 4S 300 Fi EN

CAMBIO 6M 4T 300
GEAR BOX 4S 300

10

Pos.	Codice	Q.tà	Note	Descrizione	Description
29	F26421	1		DISTANZ. PIGNONE CATENA 250N	SPACER SPROCKET CHAIN 250N
30	04113	1		PARAOLIO 28 X 38 X 7	OIL SEAL 28 x 38 x 7
31	F40889	1		PIGNONE CATENA 4T250/300N + 125 ES - Z 13	SPROCKET 13T, DRIVE 250Fi
31	F40933	1		PIGNONE CATENA 4T250/300N + 125 ES - Z 14	SPROCKET 14T, DRIVE 250Fi
31	F40956	1		PIGNONE CATENA 4T250/300N + 125 ES - Z 12	SPROCKET 12T, DRIVE 250Fi



4T300FIEN26-M
4T 300 Fi EN - 4S 300 Fi EN

CAMBIO 6M 4T 300 (OPEN CLUTCH F1)
GEAR BOX 4S 300 (OPEN CLUTCH F1)

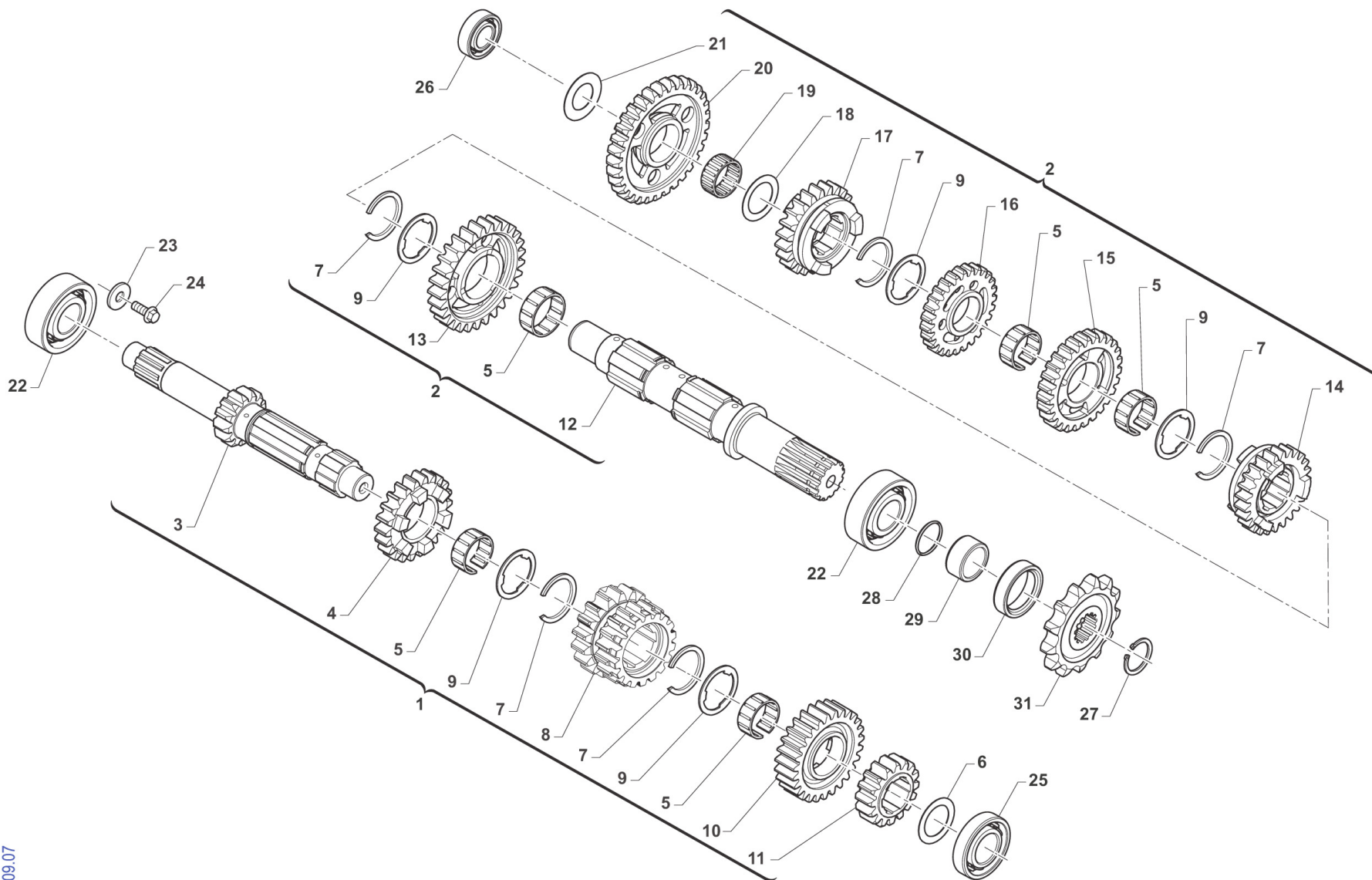

TM0009.07



4T300FIEN26-M
4T 300 Fi EN - 4S 300 Fi EN

CAMBIO 6M 4T 300 (OPEN CLUTCH F1)
GEAR BOX 4S 300 (OPEN CLUTCH F1)

11

Pos.	Codice	Q.tà	Note	Descrizione	Description
1	40336	1		ALBERO PRIM. 4T 300Fi 6M (6 ALETTE) CPL (OPEN CLUTCH F1)	
2	F40241	1		ALBERO SECONDARIO 300Fi MX 23 4T (6 ALETTE) CPL	
3	40329	1		ALBERO PRIMARIO Z 13 6 ALETTE 300 4T (F1BX)	
4	F40218	1		INGRANAGGIO 5a A.P. Z20 6 ALETTE 300 4T	
5	F19524	5		GABBIA A RULLI 22X26X10 TAGL.	NEEDLE BEARING 22 X 26 X 10
6	48253	1		SPESSORE CAMBIO 17X30X1 250	SPACER, GEAR BOX 250cc 17X30X1
7	F49869	5		SEEGER SW 24 (EST.) "SEEGER"	CIRCLIP SW 24 (EXTERNAL)
8	F40217	1		INGRANAGGIO 3/4a A.P.Z16/20 6 ALETTE 300 4T	
9	48258	5		SPESSORE DENT.CAMBIO INT.55 6M	SPACER GEAR INT.55 6S
10	F40219	1		INGRANAGGIO 6a A.P. Z22 6 ALETTE 300 4T	
11	F40216	1		INGRANAGGIO 2a A.P. Z15 6 ALETTE 300 4T	
12	F40220	1		ALBERO SECONDARIO 6 ALETTE 250/300 4T	
13	F40222	1		INGRANAGGIO 2a A.S. Z27 6 ALETTE 300 4T	
14	F40226	1		INGRANAGGIO 6a A.S. Z20 6 ALETTE 300 4T	
15	F40223	1		INGRANAGGIO 3a A.S. Z 23 6 ALETTE 300 4T	
16	F40224	1		INGRANAGGIO 4a A.S. Z 24 6 ALETTE 300 4T	
17	F40225	1		INGRANAGGIO 5a A.S. Z21 6 ALETTE 300 4T	
18	F48353	1		SPESSORE PS 18X25X1	SPACER 18x25x1
19	F19514	1		GABBIA A RULLI 18X22X10	NEEDLE CAGE 18X22X10
20	F40221	1		INGRANAGGIO 1a A.S. Z31 6 ALETTE 300 4T	
21	48012	1		RASAMENTO A/S M/M SPESS.0,5	SPACER, 26x17x0,5
22	F03368	2		CUSCINETTO 62/22 C3 22x50x14	BEARING 62/22 C3 22x50x14
23	49603	1		RONDELLA M 6,4 X 12 X 1,6	WASHER 6x12
24	49480	1		VITE TCEI 6X10 UNI 5931	BOLT TCEI 6X10
25	03254	1		CUSCINETTO A.P.4 Tempi 2RS1/C3	BUSH, MAINSHAFT 2RS/C3 4S
26	F03367	1		CUSCINETTO 6003 TN9C3 17x35x10	BUSH, 6003 TN9 C3 17x35x10
27	49217	1		SEEGER E22 ANELLO ALB/S	CIRCLIP D.22 - COUNTERSHAFT



4T300FIEN26-M
4T 300 Fi EN - 4S 300 Fi EN

CAMBIO 6M 4T 300 (OPEN CLUTCH F1)
GEAR BOX 4S 300 (OPEN CLUTCH F1)

11

Pos.	Codice	Q.tà	Note	Descrizione	Description
28	F12320	1		O RING BOCCOLA PIGNONE 250/09	O-RING NBR 2087
29	F26421	1		DISTANZ. PIGNONE CATENA 250N	SPACER SPROCKET CHAIN 250N
30	04113	1		PARAOLIO 28 X 38 X 7	OIL SEAL 28 x 38 x 7
31	F40889	1		PIGNONE CATENA 4T250/300N + 125 ES - Z 13	SPROCKET 13T, DRIVE 250Fi
31	F40933	1		PIGNONE CATENA 4T250/300N + 125 ES - Z 14	SPROCKET 14T, DRIVE 250Fi
31	F40956	1		PIGNONE CATENA 4T250/300N + 125 ES - Z 12	SPROCKET 12T, DRIVE 250Fi



4T300FIEN26-M
4T 300 Fi EN - 4S 300 Fi EN

CENTRIFUGATORE AVVIAMENTO

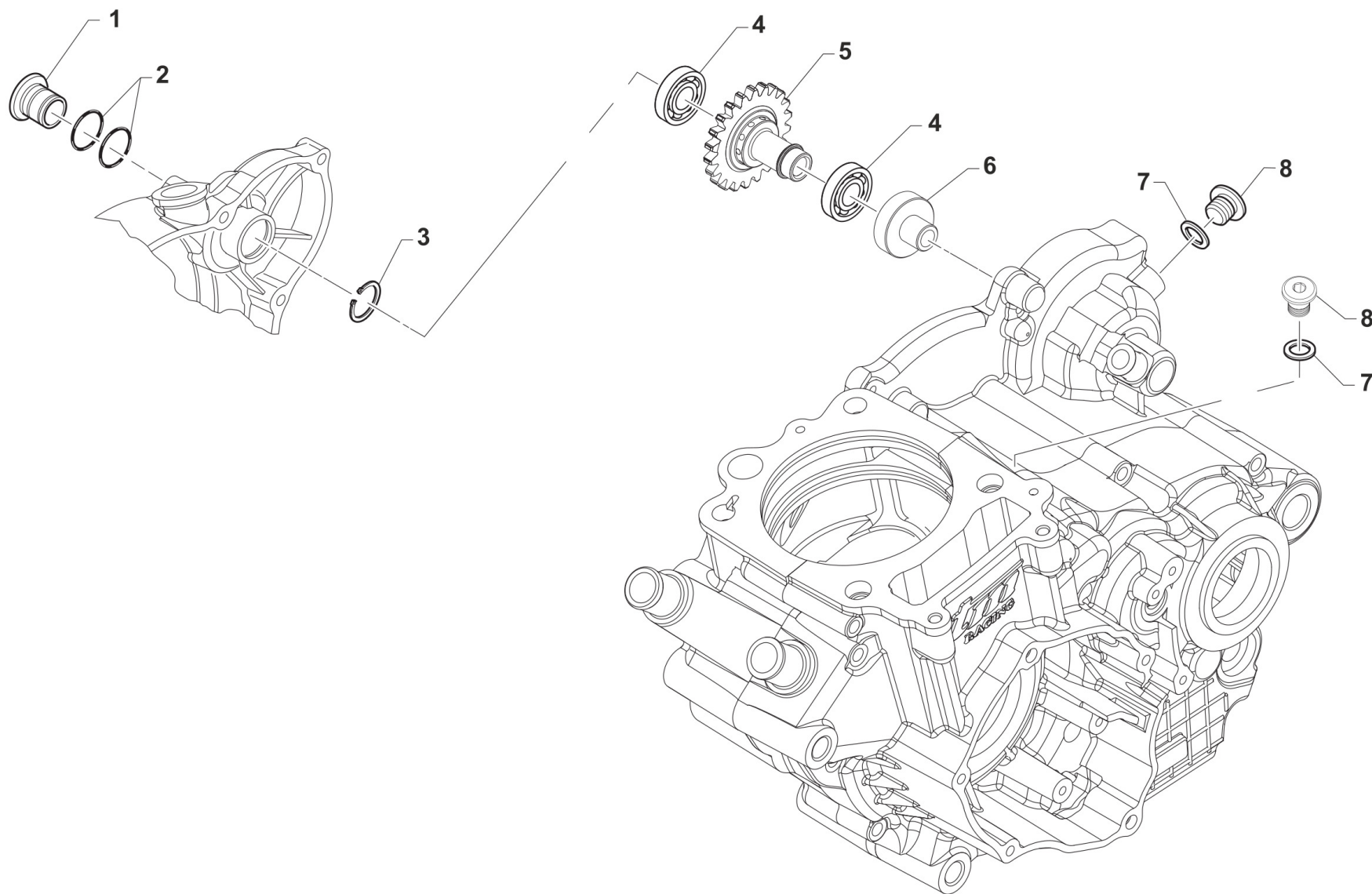

TM 0010.01



4T300FIEN26-M

4T 300 Fi EN - 4S 300 Fi EN

CENTRIFUGATORE AVVIAMENTO

12

Pos.	Codice	Q.tà	Note	Descrizione	Description
1	26234	1		TAPPO FORO ALBERINO M/M 250/300 4T	
2	12092	2		O RING NBR14x2 REGISTRO ALTE VELOCITA'	
3	F49914	1		SEEGER E 18	CIRCLIP E D.18
4	03149	2		CUSCINETTO 61902-2RS1/C3	
5	40223	1		INGR. CENTRIFUGATORE Z24 300 4T	
6	F26518	1		SUPPORTO CUSCINETTO 61902	
7	F49939	2		RONDELLA RAME 8 X13 X 1,5	WASHER COPPER 8,5X13X1,5
8	F49823	2		TAPPO M 8 X 1,25 L = 10 mm ROT.BILANC.250N e CARTER	PLUG, M 8 x 1,25 L = 10 mm SHAFT 250N

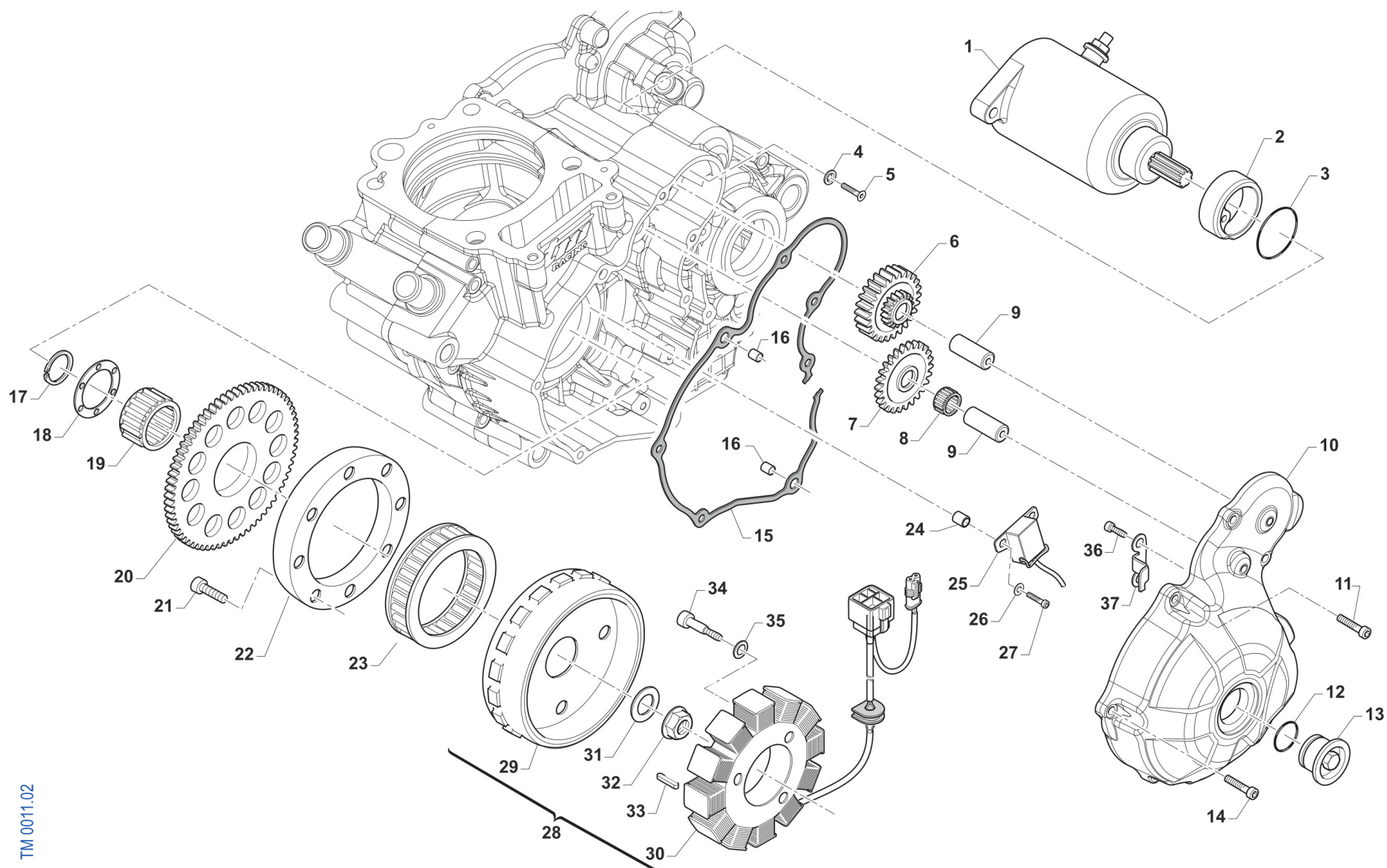

TM 0011.02



4T300FIEN26-M
4T 300 Fi EN - 4S 300 Fi EN

ACCENSIONE ES (3 FORI)

13

Pos.	Codice	Q.tà	Note	Descrizione	Description
1	F68145	1		MOTORINO AVVIAMENTO 250N M08 SM 14 A8323-048-00-000	E-STARTER ENGINE 250 4 S 08->
2	F26341	1		BOCCOLA CENTRAGGIO MOT.AVVIAM.	COLLAR, EL. STARTER
3	F12309	1		O RING 2150	O-RING, 2150
4	49675	1		RONDELLA 7 x 13,9 x 1,5	
5	49399	1		VITE TSEI 5X12	BOLT TSEI 5x12
6	40224	1		INGRANAGGIO DOPPIO 4T ESSOSTITUISCE F40839	GEAR, DOUBLE, ELECTRIC STARTER REPLACE CODE F40839
7	F40808	1		INGR. FOLLE AVVIAMENTO EL.	INTERMEDIATE GEAR
8	F19501	1		GABBIA A RULLI 10X13X10 4T	NEEDLE CAGE 10X13X10 F.S.
9	F28568	2		ALBERINO LUNGO ING. AVV.ELETTR	SHAFT, EL. STARTER GEAR
10	F30962	1		COPERCHIO ACC. 250Fi ES 11/-> ATTACCO ACCENSIONE 3 FORI	COVER, IGNITION 250Fi ES M.11
11	49477	2		VITE TCEI 5X25 UNI 5931-912	BOLT TCEI 5X25
12	F12322	1		O RING 2106	O-RING
13	F49833	1		TAPPO COPERCHIO ACC.250Fi	COVER CAP ALUMINIUM 250Fi
14	49476	5		VITE TCEI 5X20 UNI 5931-912	BOLT TCEI 5X20
15	F05829	1		GUARNIZ.COP.ACCENSIONE ES 250N	GASKET, INGNIT.COVER ES 250Fi
16	26041	2		GRANO CENTRAGGIO D.7X8 F.5,2	DOWEL PIN 7 x 8 Hole 5,2
17	F49937	1		SEEGER ALBERO E 36 4T	CIRCLIP 36 CRANKSH. E 4S
18	F26327	1		RONDELLA ACC. 37X53X2 4T	WASHER 37X50X2 4S.
19	F19506	1		GABBIA A RULLI AVV.EL.37X42X17	NEEDLE CAGE 37X42X17 E.S.
20	F40807	1		INGR. CONDOTTO AVVIAMENTO EL.	GEAR EL. STARTER
21	F49929	8		VITE TCE BASSA 6X16 (CL. 12.9)	SCREW TCE 6 X 16
22	F26385	1		ANELLO ESTERNO PESANTE R.L.KOK	EXTERNAL RING IGNITION KOKUSAN
23	F03354	1		RUOTA LIBERA MOTORINO AVV. 4T	FREE-WHEEL ELECTRIC STARTER
24	F08074	2		BOCCOLA DISTANZIALE PICK-UP	BUSH
25	F15478	1		PICK-UP KOKUSAN	PICK-UP KOK PU5157
26	49601	2		RONDELLA 5X11	WASHER 5x11



4T300FIEN26-M
4T 300 Fi EN - 4S 300 Fi EN

ACCENSIONE ES (3 FORI)

13

Pos.	Codice	Q.tà	Note	Descrizione	Description
27	49476	2		VITE TCEI 5X20 UNI 5931-912	BOLT TCEI 5X20
28	F15550.02	1		GENERATORE KOK 9022 ES KOK/SUM CONNETTORI: REG. KOK + SUMIT.	GENERATOR KOK. 9022 EL.STARTER
29	F15552	1		ROTORE KOKUSAN YF9022	ROTOR IGNITION KOKUSAN YF9022
30	F15551	1		STATORE KOKUSAN YS 9022	STATOR KOKUSAN YS 9022
31	49613	1		RONDELLA ACCIAIO 12	STEEL WASHER 12
32	49056	1		DADO ACCENSIONE MX/E 12 x 1.25	NUT, IGNITION 100cc
33	F49853	1		CHIAVETTA 5X3X25 UNI7510R.F.A.	WOODRUFF KEY, 5x3x25
34	49477	3		VITE TCEI 5X25 UNI 5931-912	BOLT TCEI 5X25
35	49107	3		RONDELLA SCHNORR ZIG. M5	WASHER 5
36	49553	2		VITE TCEI 4X8 5931-912 Brun	BOLT TCEI 4X8
37	F30945	1		PROTEZIONE CAVI ACC.NE 250N	PROTECTION IGNITION WIRES 250N