



2T144MX26-M

2T 144 MX

2S 144 MX

11/11/2025

TM MOTO SRL UNIPERSONALE - VIA FANO, 6 - 61122 PESARO – ITALY

WWW.TM-MOTO.IT



2T144MX26-M
2T 144 MX - 2S 144 MX

SOMMARIO
TABLE OF CONTENTS

CILINDRO - CYLINDER.....	3
MOTORINO VALVOLA - ELECTRIC VALVE SYSTEM.....	6
ALBERO MOTORE - PISTONE - CRANKSHAFT - PISTON.....	8
ACCENSIONE - IGNITION.....	10
BASAMENTO - CRANKCASE.....	12
FORCHETTE CAMBIO - GEAR FORKS.....	14
FRIZIONE - CLUTCH.....	17
COPERCHI FRIZIONE E CENTRIFUGA.....	20
CAMBIO 144 MX 6M.....	22
VITI COPERCHI.....	25
VITI BASAMENTO.....	27



2T144MX26-M
2T 144 MX - 2S 144 MX

CILINDRO
CYLINDER

1

Pos.	Codice	Q.tà	Note	Descrizione	Description
1	01134	1	MY20	CILINDRO 144 2T MX/EN MY2020 CPL (CARB)	CYLINDER 144 2S EN/MX MY20 ASSY
2	02025	1		TESTA 144 CR/E EV M. 2013	HEAD 144cc MX/END M.13->
3	12003	1		O RING TESTA 125/144 910 NBR	O-RING, HEAD 125 90/06 KV8910
4	12021	1		O RING PREFORMATO CIL.125/12->	O-RING, HEAD 125EV M. 2012
5	49358	6		VITE TE F/R 6X30 Ch.8	BOLT 6X30 T.8
6	21017	1		PIPETTA CANDELA NGK LB05EMH	CAP, NGK SPARK PLUG LB05EMH
7	06011	1		CANDELA NGK BR9EG	SPARK PLUG, NGK BR9EG
8	49640	4		DADO M 8 FLANGIATO CHIAVE 12	NUT 8mm, FLANGE
9	05530	1		GUARN. B/CIL 125 M.2012 0,10	GASKET, CYL 125EV M.12/-> 0,10
9	05531	1		GUARN. B/CIL 125 M.2012 0,15	GASKET, CYL 125EV M.12/-> 0,15
9	05532	1		GUARN. B/CIL 125 M.2012 0,20	GASKET, CYL 125EV M.12/-> 0,20
9	05533	1		GUARN. B/CIL 125 M.2012 0,30	GASKET, CYL 125EV M.12/-> 0,30
9	05534	1		GUARN. B/CIL 125 M.2012 0,40	GASKET, CYL 125EV M.12/-> 0,40
9	05535	1		GUARN. B/CIL 125 M.2012 0,50	GASKET, CYL 125EV M.12/-> 0,50
10	49399	1		VITE TSEI 5X12	BOLT TSEI 5x12
11	30217	1		TAPPO SX ALB.COM.VALV.PAL.125	SIDE COVER
12	F12308	1		O RING 17,5 - 1,5	O-RING 17,5 - 1,5
13	19060	1		ASTUCCIO A RULLI HK 1212	NEEDLE CAGE HK 1212
14	01133	1	MY20	CILINDRO 144 2T MX/EN MY2020 NUDO (CARB)	CYLINDER 144 2S MY20
15	04115	1		PARAOLIO G 12X18X3	OIL SEAL 12x18x3
16	26258	1	MY20	FLANGIA PORTACUSC. ALB.VALV.250/300 Fi 125/144 MY 20/24	FLANGE, BEARING HOLDER
17	49757	1		VITE TBCE 5 X 12	BOLT TBCE 5X12
18	03156	1		CUSCINETTO V.SC.C.12 698LLU/5K	BUSH, EXHAUST VALVE 698LLU
19	49220	1		SEEGER INT.19	SEEGER I 19
20	49630	1	MY20	DADO M 4 (BASSO)	NUT 4mm, LOW
21	28108	1	MY20	LEVA INTERNA COMANDO VALVOLE EES-2 125/144 2020	LEVER, INTERNAL, VALVE
22	49874	1	MY20	VITE TE 4X16	BOLT TE 4X16



2T144MX26-M
2T 144 MX - 2S 144 MX

CILINDRO
CYLINDER

1

Pos.	Codice	Q.tà	Note	Descrizione	Description
23	28263	1	MY20	LEVA ESTERNA COMANDO VALVOLE EES-2	LEVER, EXTERNAL, VALVE
24	26168	1	MY20	PERNO MOLLA EES-2 16066	PIN, SPRING
25	F19536	1	MY20	RULLO D. 5 X 12 M6 DIN 6325	PIN 5X12
26	16066	1	MY20	MOLLA EES-2	SPRING EES-2
27	49355	3		VITE TE F/R 6X16 Ch.8	BOLT 6X16 T.8
28	13081	1		COLLETTORE SCA. 125 12/-> 3F	MANIFOLD EXHAUST 125cc 12->
29	26130.12	1		SPESS. REG. CIL.125 2012 1.2	SPACER CYL. 125 ->12 1.2
29	26130.13	1		SPESS. REG. CIL.125 2012 1.3	SPACER CYL. 125 ->12 1.3
29	26130.14	1		SPESS. REG. CIL.125 2012 1.4	SPACER CYL. 125 ->12 1.4
29	26130.15	1		SPESS. REG. CIL.125 2012 1.5	SPACER CYL. 125 ->12 1.5
29	26130.16	1		SPESS. REG. CIL.125 2012 1.6	SPACER CYL. 125 ->12 1.6
29	26130.17	1		SPESS. REG. CIL.125 2012 1.7	SPACER CYL. 125 ->12 1.7
29	26130.18	1		SPESS. REG. CIL.125 2012 1.8	SPACER CYL. 125 ->12 1.8
29	26130.19	1		SPESS. REG. CIL.125 2012 1.9	SPACER CYL. 125 ->12 1.9
30	26147	1	MY20	BOCCOLA DIST. CIL. 250/300 2015 + 125 2020	BUSH
31	22147	1		VALVOLE SCARICO 144 EV M2013	POWER VALVE 144cc MY13
32	28059	1		ALBERO COMANDO PALETTE 125	SHAFT, BOOSTER 125
33	19061	1		BOCCOLA IR 8X12X12.5	BUSH, IR 1X12X12,5
34	26167	1	MY20	PIATTELLO GUIDA MOLLA EES-2 16066	COLLAR, SPRING
35	49676	1	MY20	DADO M 6X1 FLANG. AUTOBL.ACC.	NUT, FLANGED M6 X 1 S.B.



2T144MX26-M
2T 144 MX - 2S 144 MX

MOTORINO VALVOLA ELECTRIC VALVE SYSTEM

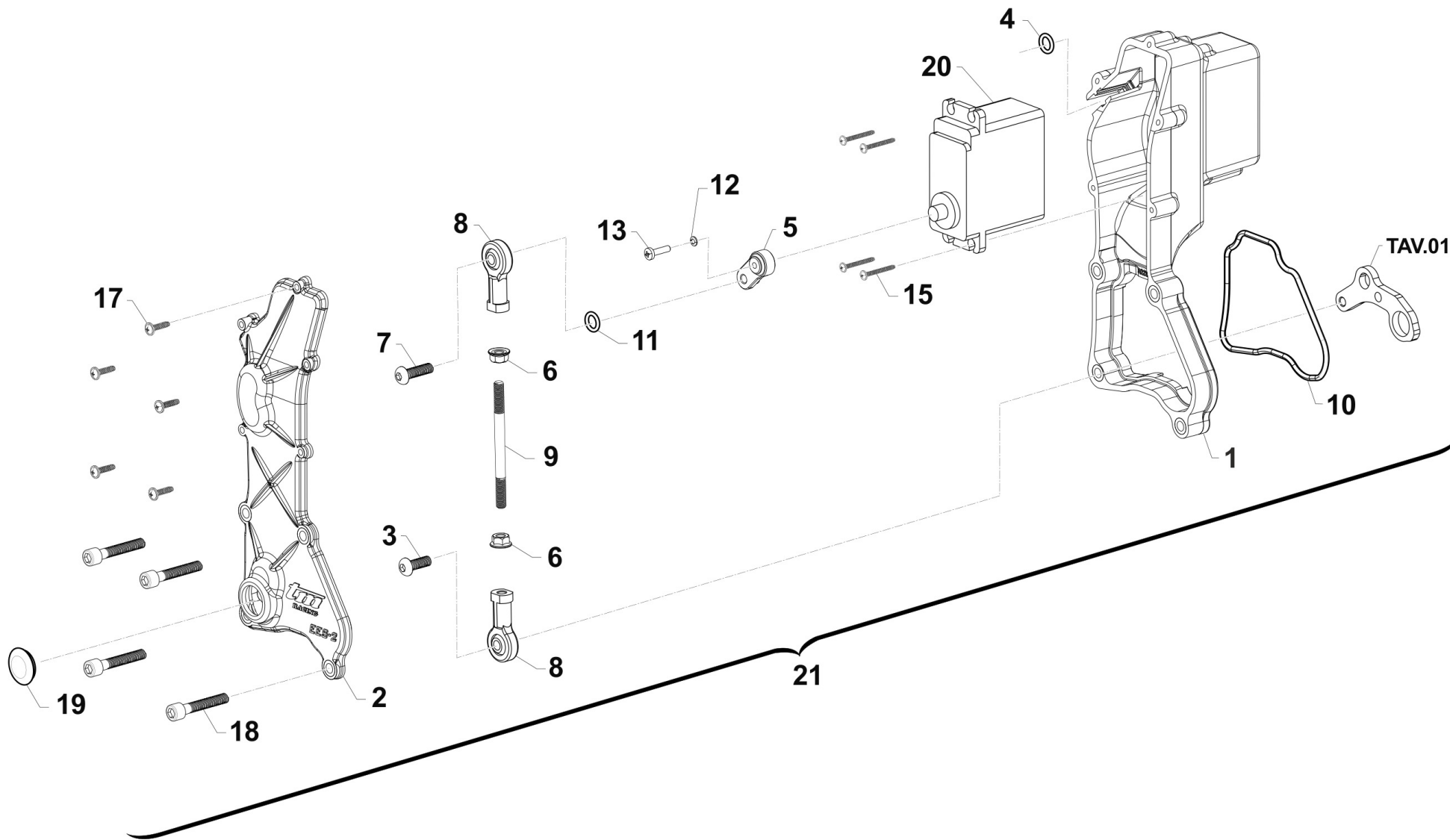

TM 0709



2T144MX26-M
2T 144 MX - 2S 144 MX

MOTORINO VALVOLA
ELECTRIC VALVE SYSTEM

2

Pos.	Codice	Q.tà	Note	Descrizione	Description
1	30291	1		CARTER EES-2 125/144 2T FI	CASE, PLASTIC, ENGINE VALVE
2	30392	1		COPERCHIO CARTER EES-2 125/144 2T FI	
3	49472	1		VITE TCEI 5X12 UNI 5931-912 Brun	BOLT TCEI 5X12
4	12060	1		O RING CAPICORDA CAVO FRIZIONE	O RING CLUTCH CABLE
5	28266.0	1		LEVA SERVOMOTORE EES-2 DENTATURA 0	LEVER
5	28266.1	1		LEVA SERVOMOTORE EES-2 DENTATURA 1	LEVER
6	49632	2		DADO M 5 x 0,8 ZB	NUT 5mm
7	49929	1		VITE 10.9 TBCEI 5 x 18 UNI 7380	BOLT
8	72251	2		SNODO MECCANISCO VALVOLA EES-2 125/250/300	JOINT EXHAUST VALVE EES-2 250/300
9	28109	1		ASTINA COLLEGAMENTO UNIBALL EES-2 125/144 2020	ROD, UNIBALL 125/144 MY20
10	12042	1		O RING COP. VALVOLA EES-2	O-RING
11	F12301	1		O RING 106 4T PIOGGIA CAMBIO	O-RING, 106 GEAR F.S.
12	49124	1		RONDELLA SCHNORR ZIG. 2.5	
13	49881	1		VITE T.C. 2,5X12	
15	49973	4		VITE STS-Plus KN6031 2.2X20 PLASTICA	BOLT
17	490021	5		VITE TCBL 3.0X 16 FL. X PLAST.	
18	49478	4		VITE TCEI 5X30 UNI 5931	BOLT TCEI 5X30
19	21009	1		TAPPO GOMMA COPERCHIO VALV.SC.	RUBBER, COVER
20	22500	1		SERVOMOTORE VALV.SCARICO HITEC	EL. ENGINE EXHAUST VALVE HITEC
21	22502.20	1		SERVOMOTORE V/SC. CPL 125/144 MY20	EL. ENGINE EXHAUST, 125/144 MY20 ASSY



2T144MX26-M
2T 144 MX - 2S 144 MX

ALBERO MOTORE - PISTONE
CRANKSHAFT - PISTON

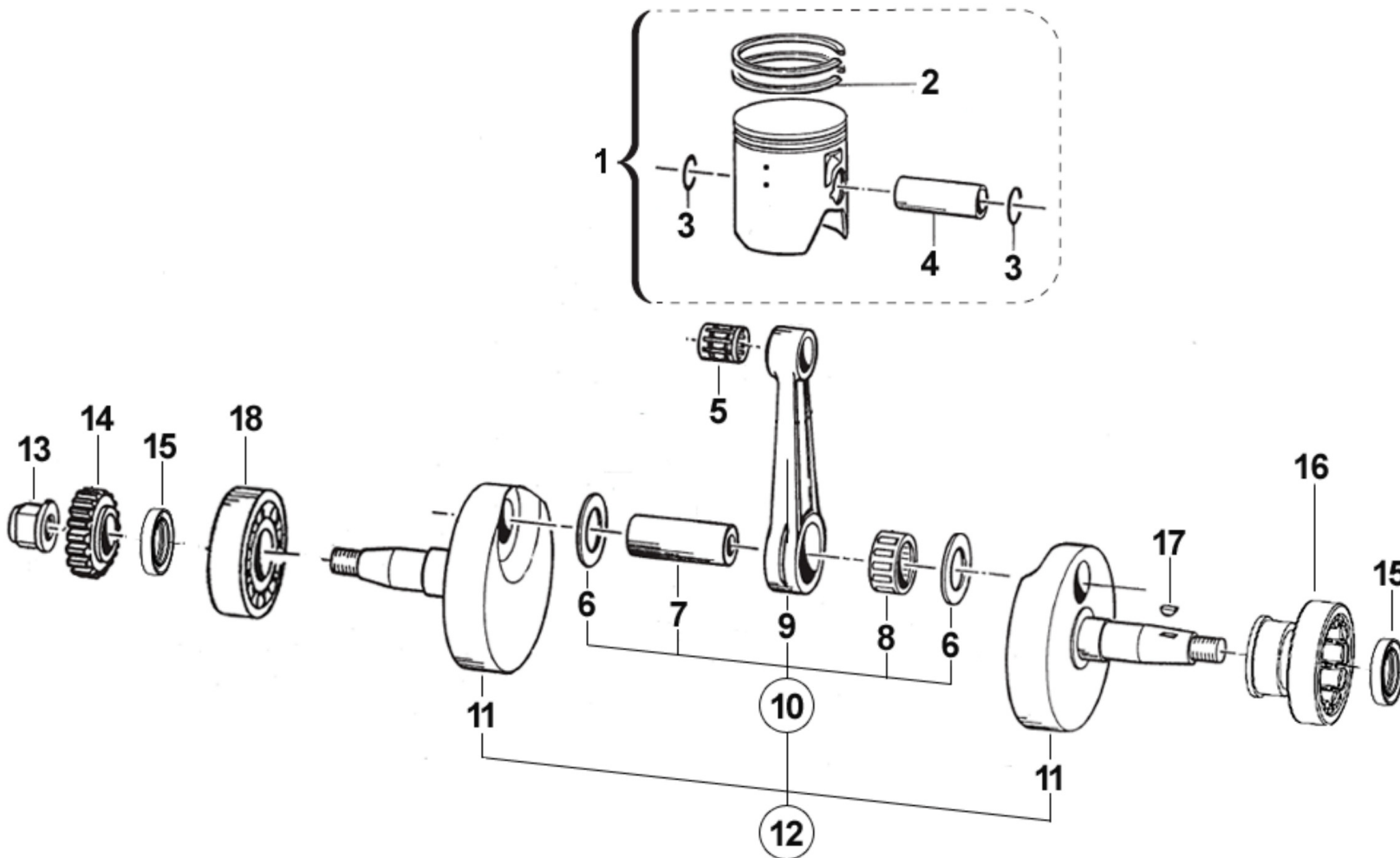

TM14419-003



2T144MX26-M
2T 144 MX - 2S 144 MX

ALBERO MOTORE - PISTONE
CRANKSHAFT - PISTON

3

Pos.	Codice	Q.tà	Note	Descrizione	Description
1	10023.94	1		PISTONE 55,94 2F 144cc CPL	PISTON 55,94 2R 144cc ASSY
1	10023.95	1		PISTONE 55,95 2F 144cc CPL	PISTON 55,95 2R144cc ASSY
2	11065	2		SEGMENTO 56 X 1 144cc	RING 56X1 144cc
3	09004.1	2		ANELLINO SPINOTTO 15 x 1 PIST.125/144	CLIP, PISTON PIN 125 / 144
4	09008	1		SPINOTTO PISTONE 125 15X41F10	PIN, PISTON 125, 15x41 F10
5	19034	1		GABBIA SPINOTTO 15X19X17,3	TOP END B. 15X19X17,3
6	18248	2		RONDELLA ARGENTATA D.24	WASHER, SILVER ID.24
7	18079	1		ASSE ACCOPP.D.24 mm f.8 c/tapp	CRANKPIN 24 X 50,4 125/144
8	17074	1		GABBIA ARGENTATA D.24X31X16 P.	SILVER CAGE 24x31x16
9	18144	1		BIELLA FORGIATA NUDA 144 cc	CONNECTING ROD 144cc
10	18145	1		BIELLA 144cc CPL	CONROD KIT, 144cc ASSY
11	18177.13	1		COPPIA SEMIALBERI 144 EV 2013	CRANKSHAFT SIDES 144 EV13
12	18178.13	1		ALBERO MOTORE 144 EV 2013 CPL	CRANKSHAFT 144 ASSY EV M13->
13	49094	1		DADO TRASMISS.125 06 M 14 X 1.25	NUT,CLUTCH CENT.14X1.25 125 06
14	40303	1		PIGNONE COPPIA PRIMARIA Z19 CR	PRIMARY DRIVE GEAR 19T MX
14	50030	1		ESTRATTORE PIGNONE COPPIA	PRIMARY GEAR PULLEY
15	04035	2		PARAOLIO 20x30x7 PTFE	OIL SEAL 20 x 30 x 7 PTFE
16	03026	1		CUSCINETTO ALBERO MOTORE NJ206 ECP/C3HVC058	BUSH, NJ206 CRANKSHAFT
17	49010	1		CHIAVETTA VOLANO 13x5x3	WOODRUFF KEY
18	03255	1		CUSCINETTO A SFERE ALB.MOTORE 125 M.13	BUSH, CRANKSHAFT 125 M.13



2T144MX26-M
2T 144 MX - 2S 144 MX

ACCENSIONE
IGNITION

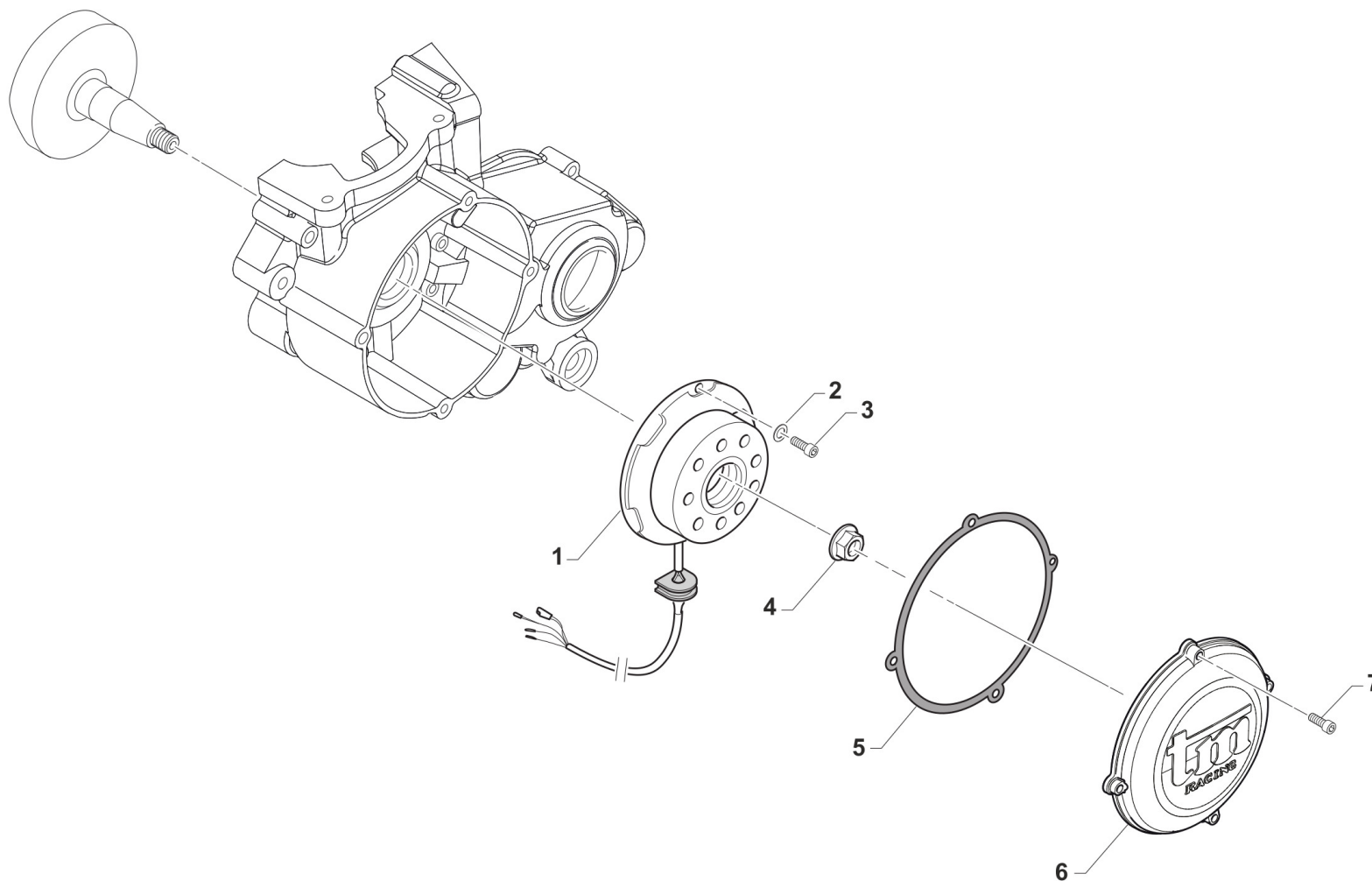

TM 0178.02



2T144MX26-M
2T 144 MX - 2S 144 MX

ACCENSIONE
IGNITION

4

Pos.	Codice	Q.tà	Note	Descrizione	Description
1	15230	1		GENERATORE KOK END 11 MX/E 12	GENERATOR KOK END 11 MX/E 12->
2	49603	2		RONDELLA M 6,4 X 12 X 1,6	WASHER 6x12
3	49484	2		VITE TCEI 6X20	BOLT TCEI 6X20
4	49056	1		DADO ACCENSIONE MX/E 12 x 1.25	NUT, IGNITION 100cc
5	05516	1		GUARN. COP.ACC. 80/125 KOKUSAN	GASKET, KOK.IGNIT.COV. 80/125
6	30211	1		COP. ACC. MX 125/144 06/11 E11	COVER, IGNITION MX 80/125 2006 KOK.
7	49477	4		VITE TCEI 5X25 UNI 5931-912	BOLT TCEI 5X25



2T144MX26-M
2T 144 MX - 2S 144 MX

BASAMENTO
CRANKCASE

5

Pos.	Codice	Q.tà	Note	Descrizione	Description
1	30177.19	1		BASAMENTO MOTORE 144 EV MY 2019	CRANKCASE 144 MY19
2	05621	1		KIT GUARN. + OR 125 2012 V.EL	GASKETS + OR 125cc M.12->
3	04034.15	1		KIT PARAOLI 125 EV M.2015	OIL SEALS 125cc EV M.15->
4	03011	1		CUSCINETTO ALBERO PRIM. 6204 Z C3	BUSH, GEAR MAINSHAFT
5	03009	2		CUSCINETTO 6202 Z C3 RIVETT.	BUSH, 6202 Z C3
6	03012	1		CUSCINETTO DESMODROMICO 6001 2RS	BUSH, 6001 2RS GEAR DRUM
7	04003	1		PARAOLIO PIGN.CATENA (26x37x7)	OIL SEAL 26 x 37 x 7
8	03010	1		CUSCINETTO 6204 C3 PIG.CATENA	BUSH, COUNTERSHAFT / SPROCKET
9	26044	3		GRANO CENTRAGGIO MOTOR.10X13,6	GRUB SCREW 10X13,6
10	26043	1		GRANO CARTER ANT. 14 X 14	GRUB SCREW 14X14
11	19041	1		ASTUCCIO A RULLI HK 35/12	BUSH NEEDLE CAGE DHK 35/12
12	49103	1		RONDELLA 14X20X1,5 ALLUMINIO	WASHER, 14 X 20 X 1.5 ALUMINUM
13	49301	1		TAPPO OLIO C/CALAM. 2T	OIL PLUG WITH MAGNET
14	26023	1		PIASTRINO CONVOGLIATORE OLIO	PLATE, OIL
15	49440	2		VITE TE 6X14	BOLT TE 6X14
16	49009	1		RACCORDO SFIATO OLIO MX/E F.4	JOINT, OIL BREATHER
17	49161	2		PRIGIONIERO 8 X 64,3 TESTA POST. 144CC M08	STUD
18	49059	2		PRIGIONIERO M8X54.5 CIL144 ANT	
19	49640	4		DADO M 8 FLANGIATO CHIAVE 12	NUT 8mm, FLANGE
20	05277	1		GUARN. PACCO LAMELLE VFORCE 3	GASKET, REED BLOCK VFORCE 3
21	20074	1		LAMELLE V-FORCE3 125/144 07/->	REEDS, V-FORCE3 125/144 07/->
22	20061	1		PACCO LAM 125/144 VF3 M. 08/->	REEDS BOX VF3 125/144 M. 08/->
23	13086	1		COLLETTORE ALL. ASP. 125/144 cc 2013/2024	ALL. INTAKE MANIFOLD 125 cc M.13->
24	13009	1		MANICOTTO COLLETTORE ASP.97/14	MANIFOLD RUBBER,INTAKE M.97/14
25	51054	2		FASCETTA SM9 D.52	CLAMP SM9 D.52mm
26	49484	4		VITE TCEI 6X20	BOLT TCEI 6X20
27	12026	1		O RING CONVOGLIATORE 125 13086	O-RING INLET MANIFOLD 125 13086



2T144MX26-M
2T 144 MX - 2S 144 MX

FORCHETTE CAMBIO GEAR FORKS

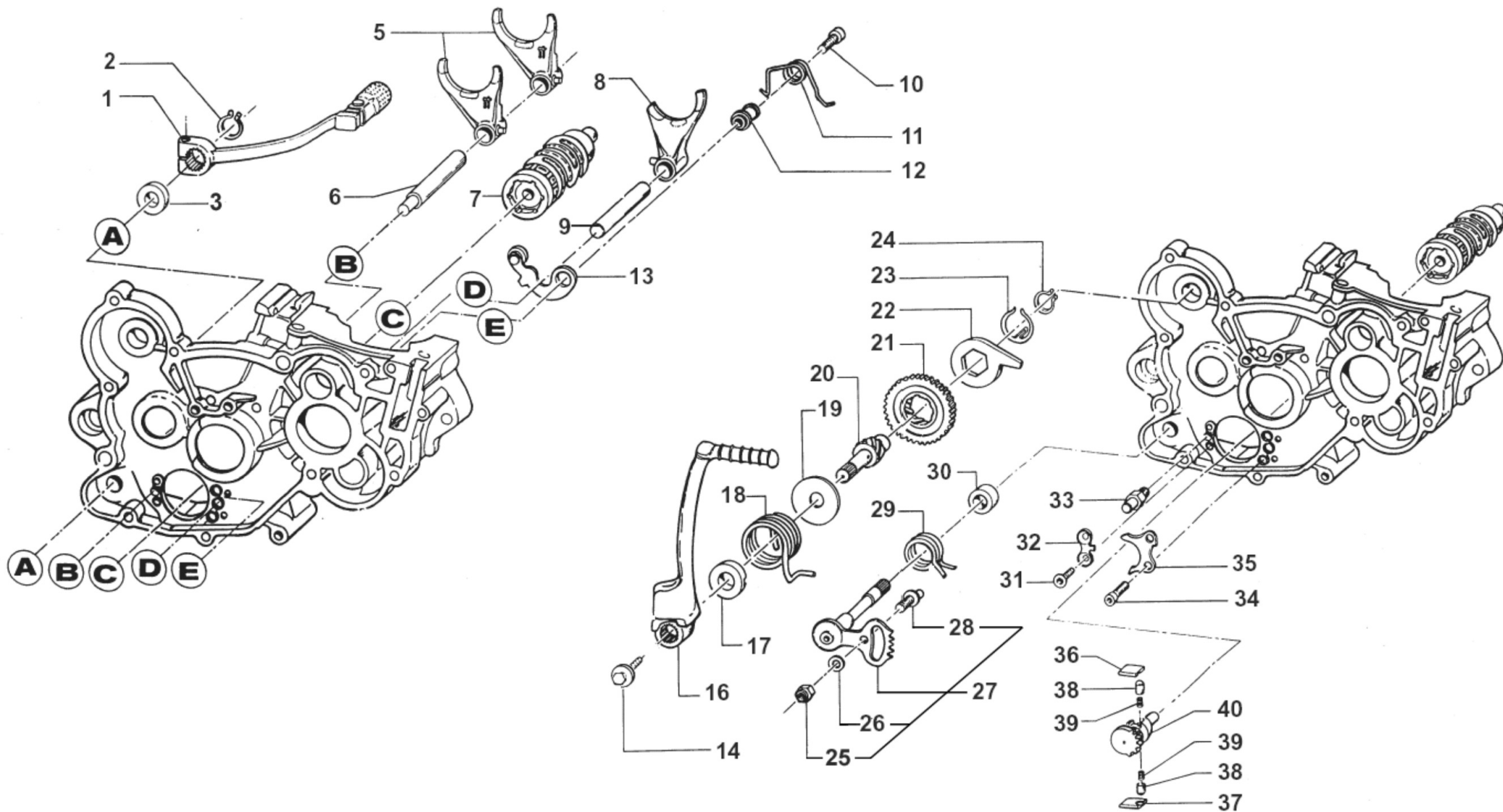



2T144MX26-M
2T 144 MX - 2S 144 MX

FORCHETTE CAMBIO
GEAR FORKS

6

Pos.	Codice	Q.tà	Note	Descrizione	Description
1	43049	1		LEVA CAMBIO 2T (485)	GEAR LEVER 2S [485]
2	49212	1		SEEGER E12 LEVA CAMBIO	CIRCLIP D.12 - EXTERNAL
3	04004	1		PARAOILIO POMPA H2O-LEVA CAMBIO	OIL SEAL 12 x 22 x 5
5	F33314	2		FORCHETTA A/S 125/250/300 CROM	SHIFT FORK SECONDARY 125/250CR
6	33256	1		PERNO FORCH.ALB.SEC. 250 / 125.99	AXEL, COUNTERSHAFT FORK 250cc
7	33004	1	MY20	ALBERO DESM.125 INTEGR. 6M CPL 125/144 6 M. CPL DI F26476	GEAR DRUM 125 6SP. 125/144 ASSY F26476
8	33016	1		FORCHETTA ALB.PRIM.125 PRT.CRM	SHIFT FORK MAINSHAFT 125 CROM.
9	33255	1		PERNO FORCH.ALB. PRIM.250 / 125.99	AXEL, MAINSHAFT FORK 250cc
10	49485	1		VITE TCEI 6X25 UNI 5931	BOLT TCEI 6x25
11	16252.12	1		MOLLA BLOCCAMARCE 125/250 2012	SPRING, STOP GEAR 125/250 M.12
12	26007	1		DISTANZIALE MOLLA BLOCCAMARCE	SPACER, STOP GEAR SPRING
13	26063.12	1		PIASTRINO BLOCCAMARCE 2012 CPL	PLATE STOP GEAR ASSY M.12->
14	49368	1		VITE TE F/R 6X10 LEVA M/M	BOLT 6X10 (Kich Starter)
16	43038	1		LEVA M/M 80/125 M. 99/->	LEVER, KICK STARTER 125 99/->
17	26005	1		DISTANZIALE MOLLA M/M	SPACER, KICK STARTER SPRING
18	16008	1		MOLLA M/M 80 / 125 / 144 cc	SPRING, KICK STARTER
19	48008	1		RONDELLA ALBERO MESSA IN MOTO	WASHER, KICK STARTER SHAFT
20	28051	1		ALBERO MESSA IN MOTO 125/144 96/18	SHAFT, KICK STARTER 125 96/05
21	40350	1		INGRANAGGIO SCORREVOLE M/M 125 / 144	SLIDING GEAR, KICK STARTER 125
22	26254	1		LEVA BATTUTA M/M 125/250 96/->	STOPPER, KICK STARTER
23	16006	1		MOLLA X INGRANAGGIO M/M	SPRING, KICKSTART SLIDING GEAR
24	49214	1		SEEGER E15 INGRANAGGIO M/M	CIRCLIP GEAR K.S. 15mm
25	49638	1		DADO M 6 ALTO AUTOBLOCCANTE	NUT 6mm, HIGHT SELF-LOCKING
26	49603	1		RONDELLA M 6,4 X 12 X 1,6	WASHER 6x12
27	28100	1		ALBERO COMANDO ING. P.TACRIC.	SHAFT, GEARSHIFT
28	26050	1		BATTUTA ECCENTRICA	ADJUSTER SELECTOR SHAFT
29	16009	1		MOLLA RITORNO LEVA CAMBIO 32CR	SPRING, RETURN GEAR LEVER 3,2



2T144MX26-M
2T 144 MX - 2S 144 MX

FORCHETTE CAMBIO
GEAR FORKS

6

Pos.	Codice	Q.tà	Note	Descrizione	Description
30	26006	1		DISTANZIALE MOLLA LEVA CAMBIO	SPACER, GEAR LEVER SPRING
31	49405	2		VITE TSEI 6X20 UMB.5933 10.9	BOLT TSEI 6x20 U.5933 10.9
32	26022	1		PIASTRINO FINE CORSA	PLATE END STROKE GEAR LEVER
33	26051	1		BATTUTA FISSA LEVA CAMBIO INT.	PIN INT. END STROKE GEAR LEVER
34	49483	2		VITE TCEI 6X16 UNI 5931	BOLT TCEI 6X16
35	26021	1		PIASTRINO RIENTRO CRICCHETTI	PLATE, RATCHET
36	26060	1		CRICCHETTO CAMBIO SUPERIORE	RATCHET UP, GEAR
37	26061	1		CRICCHETTO CAMBIO INFERIORE	RATCHET DOWN, GEAR
38	26062	2		PUNTALE PER CRICCHETTO CAMBIO	PIN, RATCHET GEAR
39	16012	2		MOLLA PER PUNTALE	SPRING, GEARBOX PIN
40	40310	1		INGRANAGGIO PORTACRICCHETTI	DRUM SHIFTER GEAR



2T144MX26-M
2T 144 MX - 2S 144 MX

FRIZIONE
CLUTCH

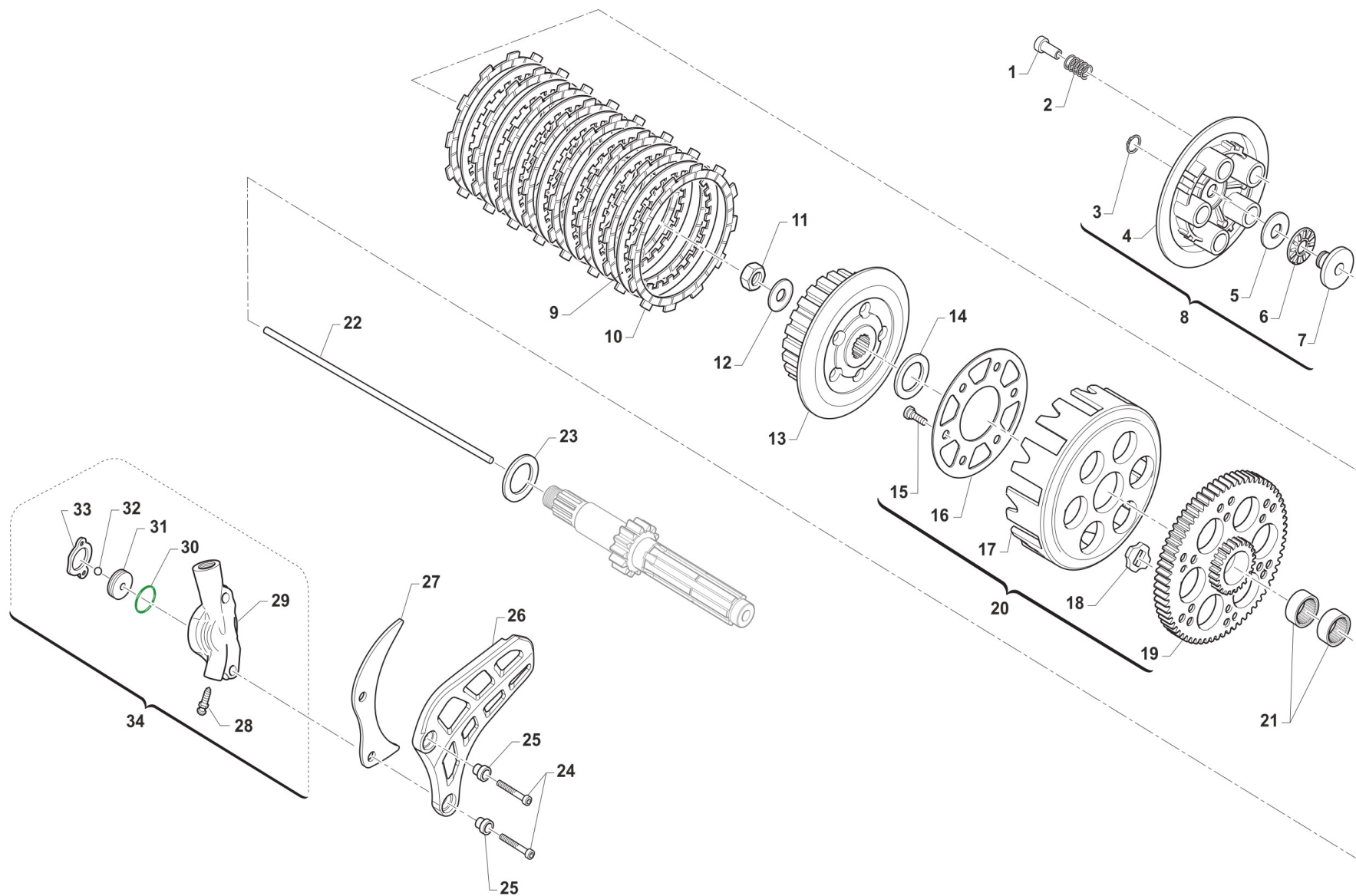

TM0174



2T144MX26-M
2T 144 MX - 2S 144 MX

FRIZIONE
CLUTCH

7

Pos.	Codice	Q.tà	Note	Descrizione	Description
1	49057	5		DADO FRIZIONE ERGAL 125/144	NUT, CLUTCH KZ10 ERGAL
2	16020	5		MOLLA FRIZIONE 125 C/E 03/08BA	SPRING, CLUTCH 125 MX/E 03/->
3	49211	1		SEEGER E10x1 ANELLO PIATT.REG.	CIRCLIP D.8,4 - EXTERNAL
4	35015	1		PIATTO SPINGIDISCO FRIZIONE 85/100/112/125/144	PLATE, CLUTCH PRESS.125 97/02
5	19021	1		RONDELLA X GABBIA RULLI AS1024	WASHER, NEEDLE CAGE AS 1024
6	19020	1		GABBIA A RULLI RAD. AXK 1024	NEEDLE CAGE AXK 1024, RADIAL
7	26001	1		REGGISPINTA FRIZIONE	CLUTCH THRUST
8	35025	1		PIATTO SPING. FRIZIONE 85/100/112/125/144 CPL	PLATE, CLUTCH PRESSURE ASSY
9	35019	7		DISCO FRIZ. ACC. 1mm 99/05	CLUTCH PLATE, STEEL 1mm 99/05
10	35027	8		DISCO FRIZ. GUARN.CR/E 125 PRT	CLUTCH PLATE, FIBER 85/125 MX/E 93/-> ALTERNATIVE CODE FOR 35012
11	49052	1		DADO TAMBURELLO FRIZIONE	NUT, CLUTCH CENTER
12	49127	1		MOLLA A TAZZA DIN 2093 28X14,2X1,25	DISC SPRING DIN 2093 28x14,2x1,25
13	25099.14	1		TAMBURELLO FRIZIONE 125 2014	CLUTCH CENTRE 125cc M.14->
13	50124	1		CHIAVE FRIZ. 85/125 + KART CPL	CLUTCH TOOL 85/125cc + KART
14	48002	1		SPESSORE COP.PRIM.30X18X3	SPACER 30x18x3
15	49727	6		VITE PARASTRAPPI K9 M7X1X12.5	SCREW, M7X1X12,5 K9 ENGINE
16	35026	1		DISCO BATTUTA GOMM. FRIZ.KZ10B 85/125	DISC STOP RUBBERS CLUTCH KZ10B
17	25000	1		CAMPANA FRIZ.125 M.91/96 99/23	CLUTCH BASKET 125 91/96 99/05
18	21005	6		GOMMINO PARASTRAPPI FRIZIONE	RUBBER, CLUTCH BASKET
19	40402	1		COPPIA PRIM. 125 Z63	PRIMARY GEAR 63T, 125cc
20	40409	1		COPPIA PRIM. 125 Z63 CPL 99/-> 93/96	PRIM.GEAR 63T,125 Comp. 99/04
21	19013	2		GABBIA A RULLI K 20X24X12	NEEDLE CAGE 20 X 24 X 12
22	35043	1		ASTINA FRIZ. IDR. 125 200,8 mm MY 99/->	ROD, HYDR.CLUTCH 125 M. 99/04
23	48003	1		SPESSORE COP.PRIM.30X20X2	SPACER 30X20X2 PRIMARY GEAR
24	49486	2		VITE TCEI 6X30 UNI 5931-912 YZPL	BOLT TCEI 6X30
25	26212	2		BOCCOLA PROT. PIGNONE 125 F.6	COLLAR, SPROCKET 125cc H.6
26	40029	1		PROTEZIONE PIGNONE 09/-> PLAST	PROTECTION FRONT SPROCKET09/13



2T144MX26-M
2T 144 MX - 2S 144 MX

FRIZIONE
CLUTCH

7

Pos.	Codice	Q.tà	Note	Descrizione	Description
27	40022	1		PROTEZIONE ERGAL PIGNONE CAT.	PROTECTION, GEAR CHAIN ERGAL
28	35264	1		VITE SPURGO OLIO FRIZ.IDR.6X1	SCREW AIR BLED HYDRAUL.CLUTCH
29	30205	1		COP. FRIZ/IDR 80/125 95/11 NUD	OUTPUT H.CLUTCH CYLINDER
30	12259	1		O RING PISTONE FR.125/250 VITON (Verde)	O-RING, CLUTCH PISTON 125/250
31	35125	1		PISTONE POMPA FRIZ. 125 95/->	PISTON, CLUTCH PUMP 125 95/04
32	19052	1		SFERA 8 X FRIZIONE 250 5/16"	BALL, IDR. CLUTCH PUMP
33	05509	1		GUARN. POMPA FRIZ.IDR. 80/125	GASKET, HYDRAULIC CLUTCH80/125
34	30206	1		COP. FRIZ/IDR 85/125 95/-> CPL	OUTPUT H.CLUTCH CYLINDER CPL.



2T144MX26-M
2T 144 MX - 2S 144 MX

COPERCHI FRIZIONE E CENTRIFUGA

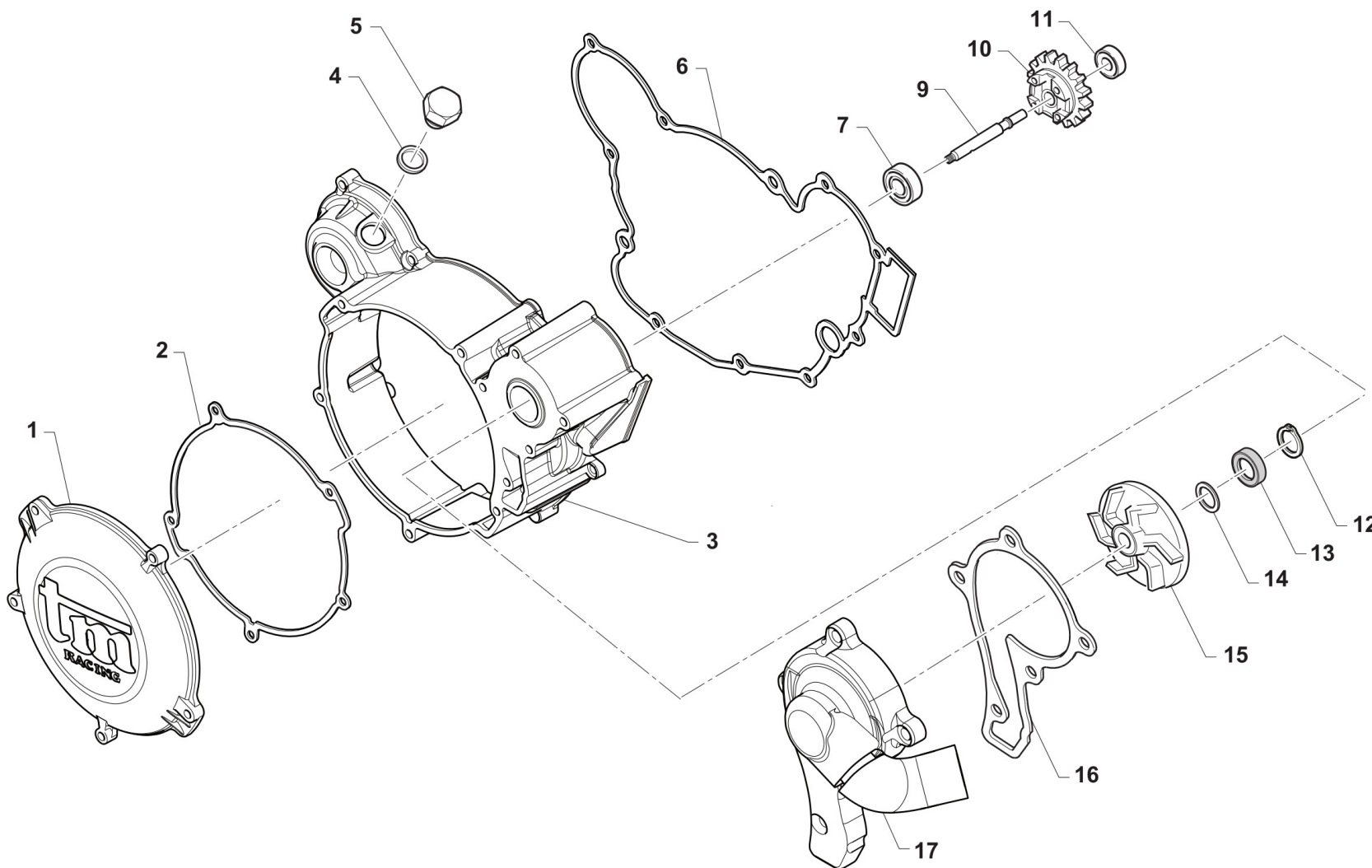

TM 0180



2T144MX26-M
2T 144 MX - 2S 144 MX

COPERCHI FRIZIONE E CENTRIFUGA

8

Pos.	Codice	Q.tà	Note	Descrizione	Description
1	30187	1		COPERCHIETTO FRIZ. 125 M.2006	COVER, CLUTCH, EXT. 125 06/->
2	05526	1		GUARN. COP.FRIZ. EST.125 06/->	GASKET, EXT.CLUTCH COVER 125/6
3	30174	1		CARTER FRIZIONE 125 M.12/->	CLUTCH COVER 125 M.12->
4	49103	1		RONDELLA 14X20X1,5 ALLUMINIO	WASHER, 14 X 20 X 1.5 ALUMINUM
5	49300	1		TAPPO CARICO OLIO	OIL PLUG, FILL
6	05527	1		GUARN. COP.FRIZ. INT.125 06/->	GASKET, CLUTCH CASE 125 06/->
7	03014	1		CUSCINETTO 608 ZC3 POMPA SCHER	BUSH, WATER PUMP 608 Z C3
9	28062	1		ALBERINO POMPA ACQUA 125 2012	SHAFT, WATERPUMP 125 M.12/->
10	40071	1		INGR COMANDO POMPA H2O 125 '12	GEAR, WATERPUMP 125 M.12/->
11	03025	1		CUSCINETTO 626 C3 POMPA H2O 06	BUSH, WATER PUMP 626 C3
12	49215	1		SEEGER I22 POMPA ACQUA	CIRCLIP D.22 WATER PUMP
13	04017	1		PARAOLIO CENTRIFUGA 06	OIL SEAL 8 X 22 X 7 TC
14	49689	1		RONDELLA 6 X 12 SP. 1.2	WASHER 6x12 sp. 1,2
15	28009	1		GIRANTE POMPA ACQUA 2006/08	IMPELLER, WATER PUMP M.06/->
16	05528	1		GUARN. POMPA ACQUA 125 2006	GASKET WATER PUMP 125cc 2006
17	30194.20	1		COPERCHIO POMPA H2O 125/144 maggiorato	



2T144MX26-M
2T 144 MX - 2S 144 MX

CAMBIO 144 MX 6M

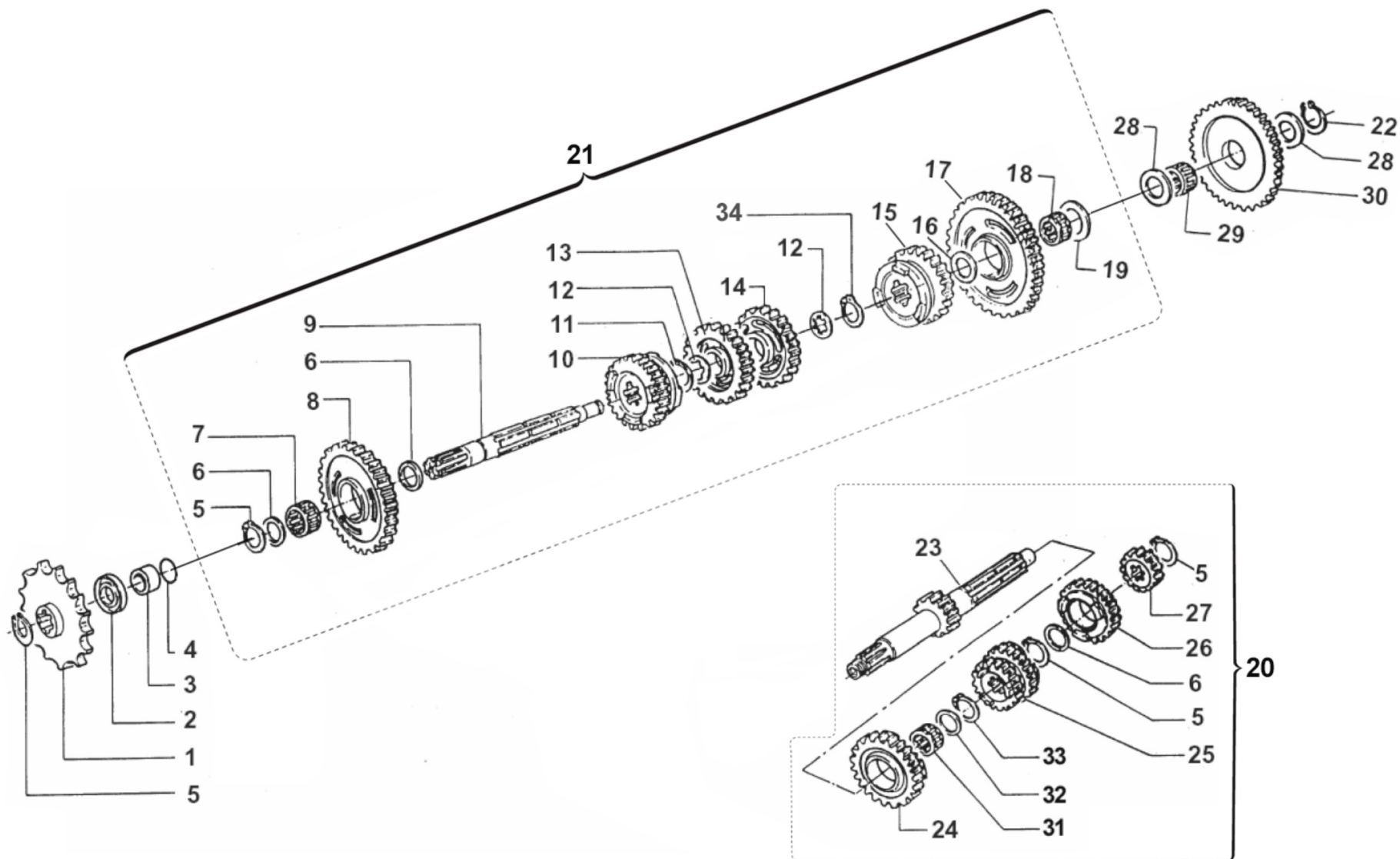



2T144MX26-M
2T 144 MX - 2S 144 MX

CAMBIO 144 MX 6M

9

Pos.	Codice	Q.tà	Note	Descrizione	Description
1	40024	1		PIGNONE CAT. Z 11 BR12 M.00/->	SPROCKET 11T, DRIVE M.00/10
1	40025	1		PIGNONE CAT. Z 12 BR12 M.00/->	SPROCKET 12T, DRIVE 125 00/->
1	40026	1		PIGNONE CAT. Z 13 BR12 M.00/->	SPROCKET 13T, DRIVE 125 00/->
2	04003	1		PARAOLIO PIGN.CATENA (26x37x7)	OIL SEAL 26 x 37 x 7
3	26002.1	1		DISTANZIALE PIGNONE (MOTO)	SPACER, MOTORCYCLE GEAR
4	12019	1		O RING PIGNONE CATENA	O-RING, DRIVE GEAR 2075
5	49216	4		SEEGER E20 PIGN.-CAMBIO-COPPIA	CIRCLIP D.20 - EXTERNAL
6	48013	3		RASAMENTO A/S 27X20X0,7	SPACER, 27x20x0,7
7	19012	1		GABBIA A RULLI K 20X24X10	BUSH NEEDLE CAGE 20 X 24 X 10
8	40708	1		INGR A.S. 2a Z 29 CR/E 90	GEAR, 2TH (29T) COUNTERSH.CR/E
9	40462.1	1		ALBERO SECONDARIO SCAN. 12 HD	
10	40456	1		INGR A.S. 6a Z 24 END 144CC	GEAR, 6TH (24T) COUNTERSHAFT E
11	49217	1		SEEGER E22 ANELLO ALB/S	CIRCLIP D.22 - COUNTERSHAFT
12	48011	2		RASAMENTO DENT.A/S 27X22X0,75	SPACER, 27x22x0,75
13	40710.1	1		INGR A.S. 4a Z 25 HD	
14	40709.1	1		INGR A.S. 3a Z 27 HD	
15	40510	1		INGR A.S. 5a Z 24 CR/E 90	GEAR, 5TH (24T) COUNTERSHAFT
16	48012	1		RASAMENTO A/S M/M SPESS.0,5	SPACER, 26x17x0,5
17	40470	1		INGRANAGGIO A.S. 1a Z 31 MX	GEAR 1St M X (31T) COUNTERSHAFT
18	19011	1		GABBIA A RULLI K 17X21X10	BUSH CAGE 17 X 21 X 10
19	48010	1		RASAMENTO ALB/S.28X15X0,5 INGI	SPACER, 28x15x0,5
20	40045	1		ALBERO PRIMAR.CPL 144 MX 6M	
21	40046.24	1		ALBERO SECONDARIO CPL 144 MX 6M RINFORZATO	
22	49214	1		SEEGER E15 INGRANAGGIO M/M	CIRCLIP GEAR K.S. 15mm
23	40713	1		ALBERO PRIMARIO Z 14 MX RINF.	MAINSHAFT MX 14T
24	40440	1		INGR. A.P. 5a Z 22 K9B/C 10 CR/E90	GEAR, 5TH (22T) MAINSHAFT
25	40702	1		INGR A.P. 3/4a Z 18/20 CR/E 90	GEAR, 3/4TH(18/20T)MAINSH.MX/E
26	40455	1		INGR A.P. 6a Z 27 END 144CC	GEAR, 6TH (27T) MAINSHAFT END. 144cc



2T144MX26-M
2T 144 MX - 2S 144 MX

CAMBIO 144 MX 6M

9

Pos.	Codice	Q.tà	Note	Descrizione	Description
27	40701	1		INGR A.P. 2a Z 16 CR/E 90	GEAR, 2ND (16T) MAINSH.MX/E 90
28	48004	2		SPESSORE INGRANAGGIO M/M	SPACER, K.STARTER GEAR
29	19010	1		GABBIA A RULLI K 15X19X10	BUSH NEEDLE CAGE 15 X 19 X 10
30	40351	1		INGRANAGGIO LIBERO M/M 125 / 144	GEAR, KICK STARTER 125
31	19071	1		GABBIA A 20X24X10 IN DUE META'	NEEDLE CAGE 20X24X10 TWO PIEC.
32	48041	1		RASAMENTO A/P 27.5X21X1 KZ10B	SPACER, MAINSHAFT 27,5X21X1 KZ
33	49222	1		SEEGER E 21 mm	CIRCLIP D.21 - EXTERNAL
34	49217.1	1		SEEGER RETTIFICATO PER 40510	SEEGER RING FOR CODE 40510



2T144MX26-M
2T 144 MX - 2S 144 MX

VITI COPERCHI

12

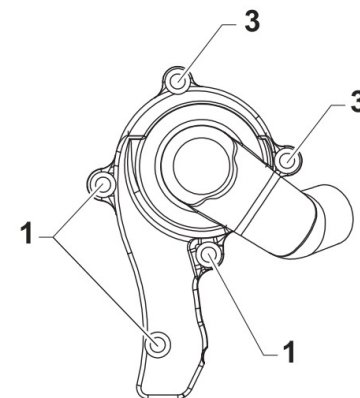
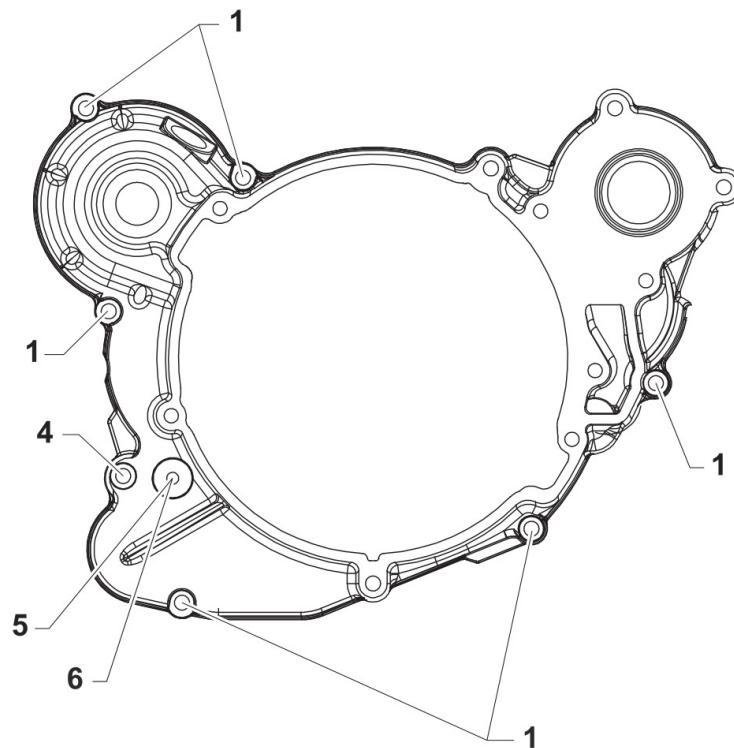
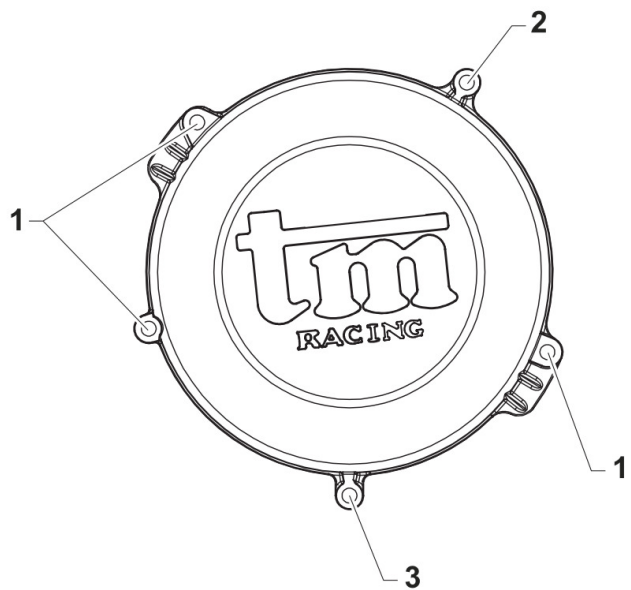

0181



2T144MX26-M
2T 144 MX - 2S 144 MX

VITI COPERCHI

12

Pos.	Codice	Q.tà	Note	Descrizione	Description
1	49476	12		VITE TCEI 5X20 UNI 5931-912	BOLT TCEI 5X20
2	49563	1		VITE TCEI 6X85	SCREW TCEI 6X85
3	49595	3		VITE TCEI 5X80 UNI 5931-912 Brun	BOLT TCEI 5X80
4	49477	1		VITE TCEI 5X25 UNI 5931-912	BOLT TCEI 5X25
5	49480	1		VITE TCEI 6X10 UNI 5931	BOLT TCEI 6X10
6	49104	1		RONDELLA 6 x 10 x 1,5 ALLUMINIO	WASHER 6 x 10 x 1.5 ALUMINUM



2T144MX26-M
2T 144 MX - 2S 144 MX

VITI BASAMENTO

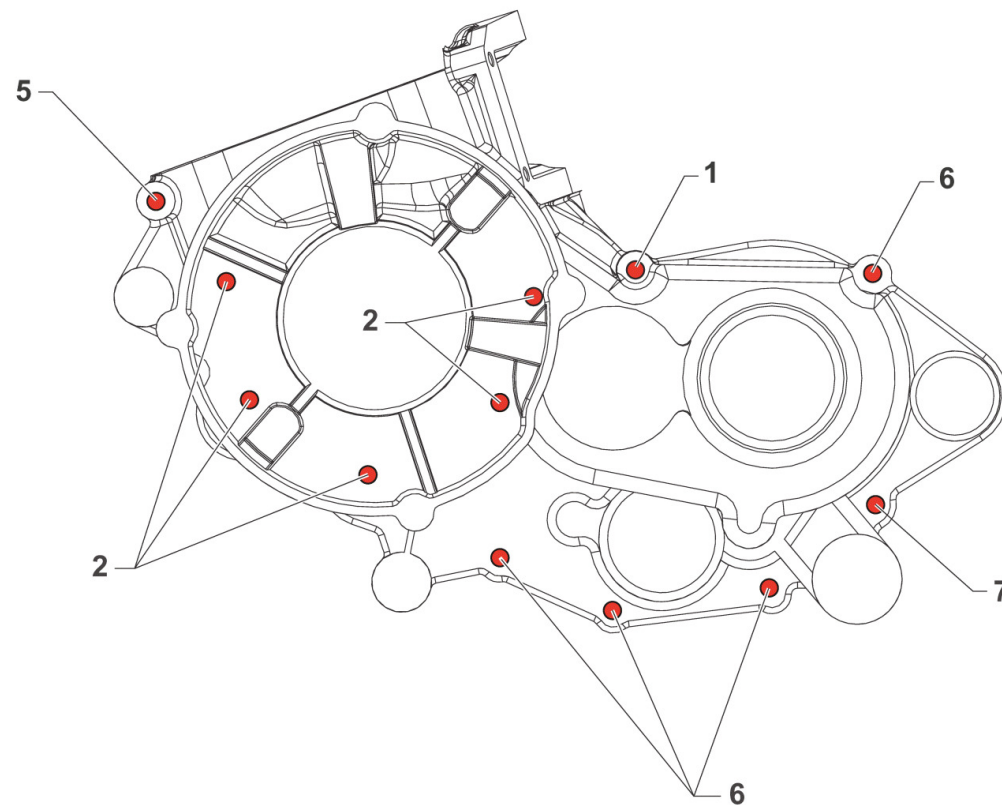
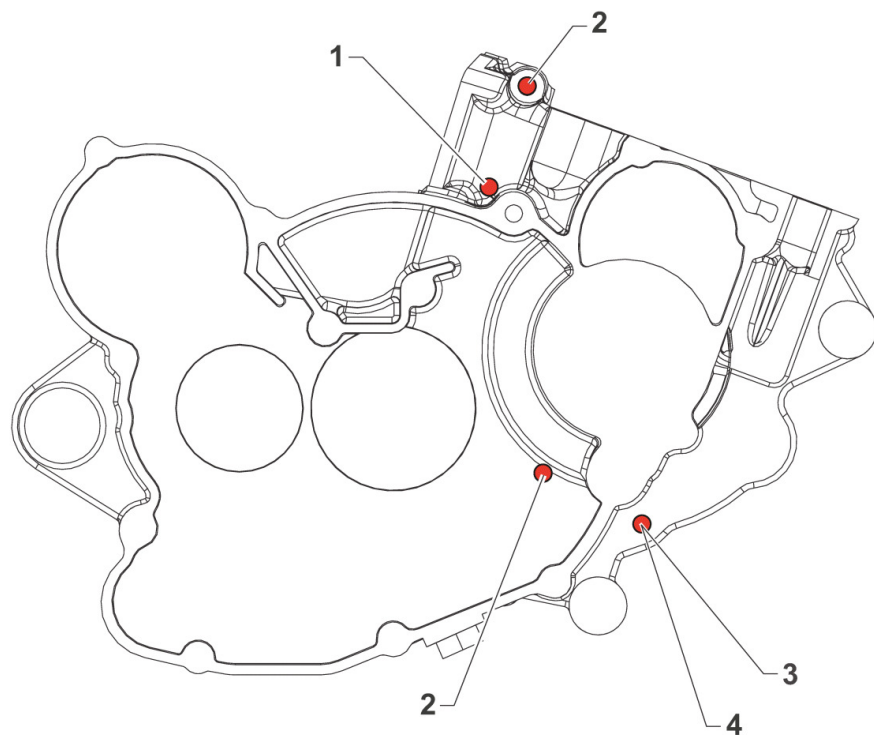



2T144MX26-M
2T 144 MX - 2S 144 MX

VITI BASAMENTO

13

Pos.	Codice	Q.tà	Note	Descrizione	Description
1	49491	2		VITE TCEI 6X55	BOLT TCEI 6X55
2	49489	7		VITE TCEI 6X45 UNI 5931	BOLT TCEI 6x45
3	49104	1		RONDELLA 6 x 10 x 1,5 ALLUMINIO	WASHER 6 x 10 x 1.5 ALUMINUM
4	49480	1		VITE TCEI 6X10 UNI 5931	BOLT TCEI 6X10
5	49490	1		VITE TCEI 6X50 UNI 5931	BOLT TCEI 6X50
6	49487	4		VITE TCEI 6X35 UNI 5931	BOLT TCEI 6X35
7	49488	1		VITE TCEI 6X40	BOLT TCEI 6x40