



2T125EN26-M

**2T 125 EN ES
ENGINE**

11/11/2025

TM MOTO SRL UNIPERSONALE - VIA FANO, 6 - 61122 PESARO – ITALY

WWW.TM-MOTO.IT



2T125EN26-M
2T 125 EN ES - ENGINE

SOMMARIO
TABLE OF CONTENTS

CILINDRO 01 - 125 MX/EN CARB. - CYLINDER 01 - 125 MX/EN CARB.....	3
CILINDRO 02 - 125 MX/EN CARB - CYLINDER 02 - 125 MX/EN CARB.....	5
ALBERO MOTORE E PISTONE - CRANKSHAFT AND PISTON.....	8
ACCENSIONE 125 EN CARB - IGNITION 125 EN CARB.....	10
FRIZIONE - CLUTCH.....	12
CARTER FRIZIONE - CLUTCH CASE.....	15
BASAMENTO E PACCO - CASE AND REEDS BOX.....	17
COMANDO CAMBIO - GEARSHIFT MECHANISM.....	19
CAMBIO EN/SMR - GEARBOX.....	22
VITI MOTORE - BOLTS.....	25



2T125EN26-M
2T 125 EN ES - ENGINE

CILINDRO 01 - 125 MX/EN CARB.
CYLINDER 01 - 125 MX/EN CARB

1

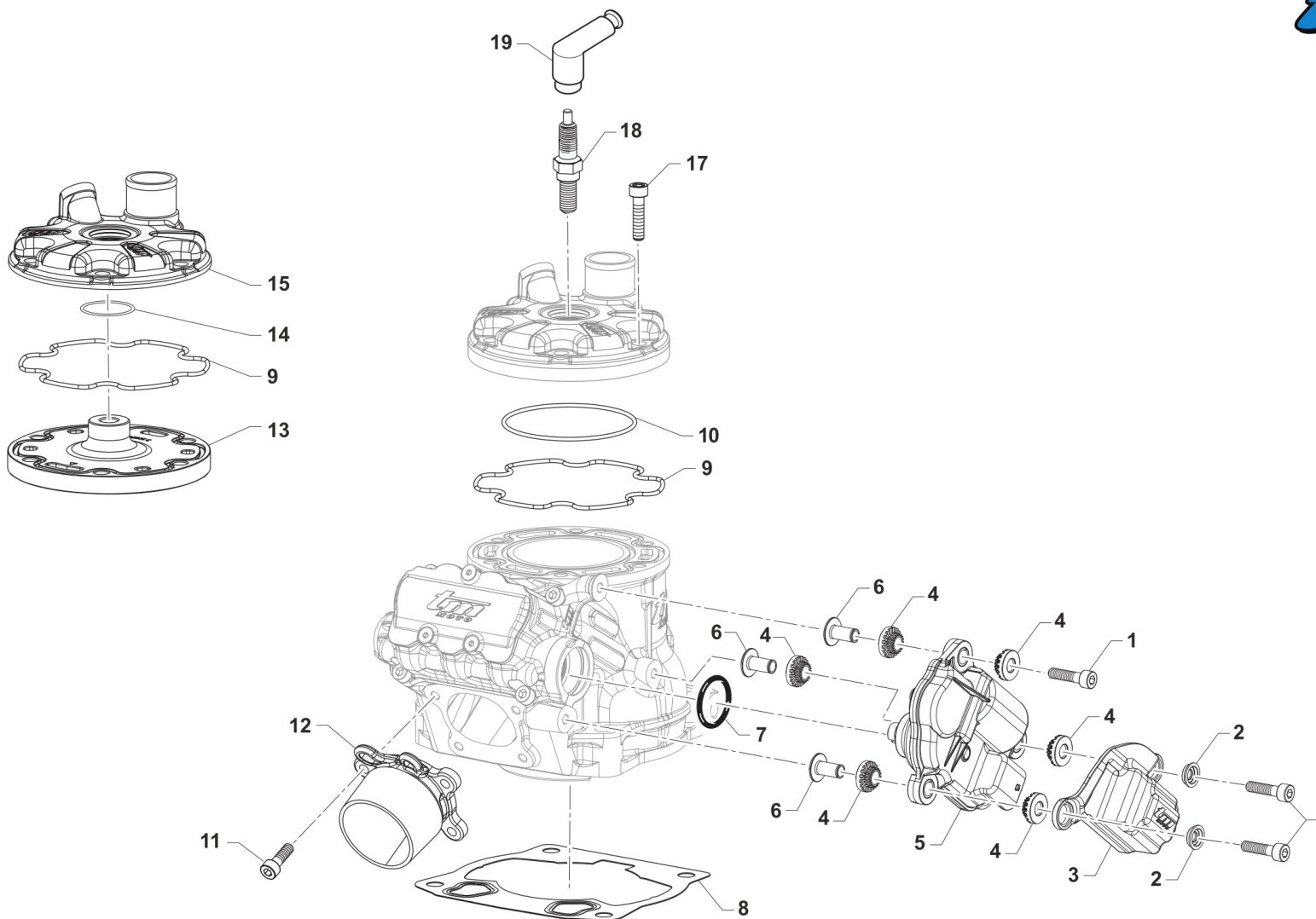

TM 0750.01



2T125EN26-M
2T 125 EN ES - ENGINE

CILINDRO 01 - 125 MX/EN CARB.
CYLINDER 01 - 125 MX/EN CARB

1

Pos.	Codice	Q.tà	Note	Descrizione	Description
1	49477	3		VITE TCEI 5X25 UNI 5931-912	BOLT TCEI 5X25
2	26238	2		BOCCOLA COVER ATTUATORE SBS 5X12X3	
3	67439	1		COVER ATTUATORE VALVOLA DI SCARICO SBS 11832 FD EVO MY2025	
4	21317	6		SILENT BLOCK 6.5X15X6.5 Z18	
5	68323	1		ATTUATORE VALVOLA DI SCARICO SBS 11832 FD EVO	
6	26241	3		BOCCOLA SOSP. ELAST. ATTUATORE VALV. SCARICO	
7	12047	1		O RING ORM 0220-30 22,0X3,0	
8	05538	1		GUARN. B/CIL 2T 125 ES MY 25 - 0,30	GASKET, CYLINDER 2S 125 ES MY25 - 0,30
8	05539	1		GUARN. B/CIL 2T 125 ES MY 25 - 0,40	GASKET, CYLINDER 2S 125 ES MY25 - 0,40
8	05540	1		GUARN. B/CIL 2T 125 ES MY 25 - 0,50	GASKET, CYLINDER 2S 125 ES MY25 - 0,50
8	05541	1		GUARN. B/CIL 2T 125 ES MY 25 - 0,60	GASKET, CYLINDER 2S 125 ES MY25 - 0,60
8	05542	1		GUARN. B/CIL 2T 125 ES MY 25 - 0,20	GASKET, CYLINDER 2S 125 ES MY25 - 0,20
9	12043	2		O RING PREFORMATO CIL.125 MY 2025	
10	12003.1	1		O RING INT.TESTA 125/144 FKM 75 SH MARRONE	O-RING, INT. HEAD 125 / 144cc VITON
11	49473	4		VITE TCEI 5X14	BOLT TCEI 5X14
12	13127	1		COLLETTORE SCARICO A 4 VITI M5 D38	
13	02035	1		CAMERA COMBUSTIONE TESTA MX EN 125 2T	COMBUSTION CHAMBER 2S 125 MX/EN MY25
14	12073	1		OR 20,00X2,00 ORM 0200-20 NBR 70	
15	02037	1		COPERCHIO TESTA 125 CARBURATORE MY 2025	
17	490048	6		VITE TCEI 7x30 8.8 5931-912	
18	F06105	1		CANDELA NGK CR9EIX CON/NIPPLO	SPARK PLUG NGK CR9EIX
19	21087	1		PIPETTA CANDELA SILICONE SCHERMATO 5K	



2T125EN26-M
2T 125 EN ES - ENGINE

CILINDRO 02 - 125 MX/EN CARB
CYLINDER 02 - 125 MX/EN CARB.

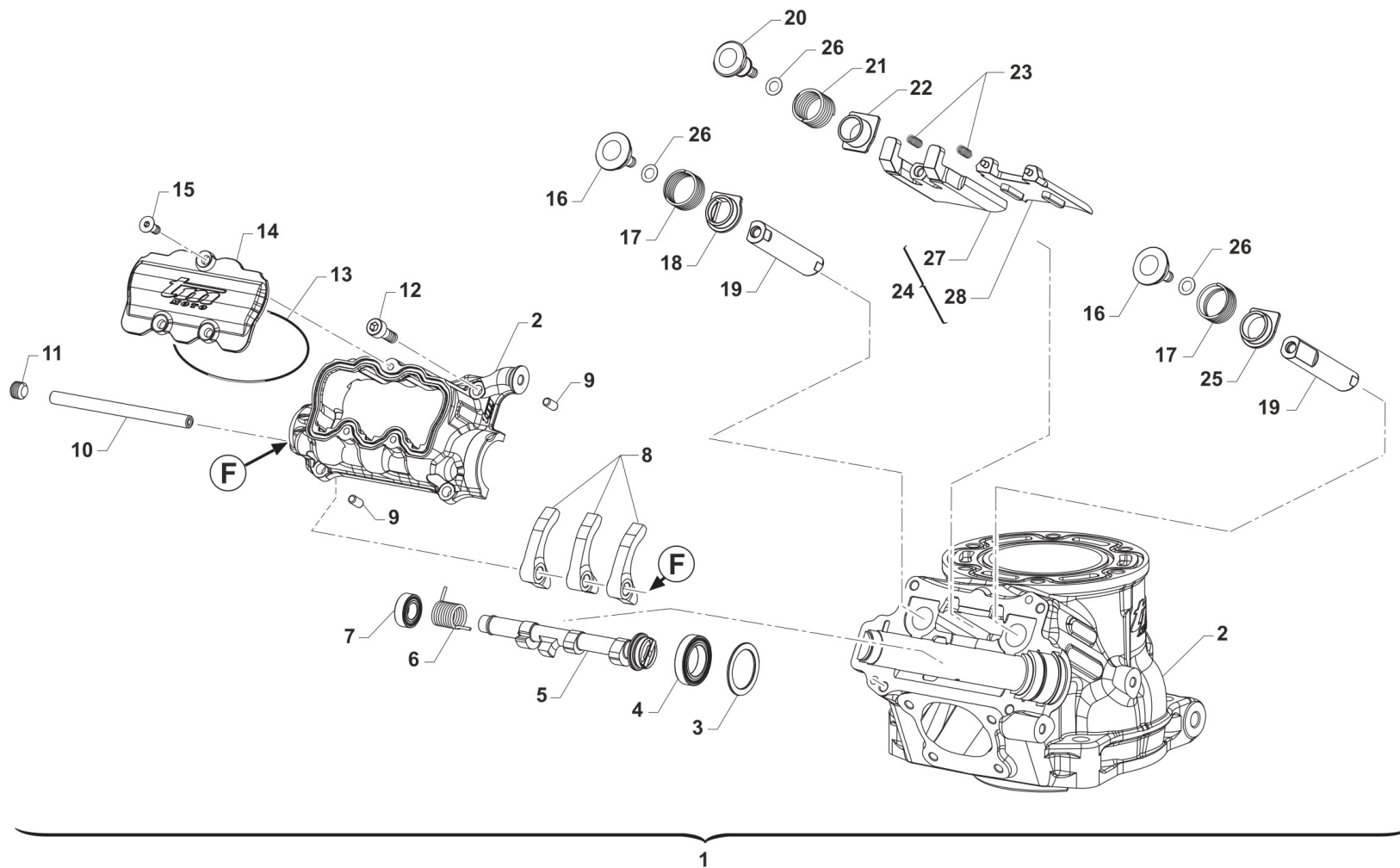

TM 0751



2T125EN26-M
2T 125 EN ES - ENGINE

CILINDRO 02 - 125 MX/EN CARB
CYLINDER 02 - 125 MX/EN CARB.

2

Pos.	Codice	Q.tà	Note	Descrizione	Description
1	01145.26	1		CILINDRO 125 MX/EN CARBURATORE MY 2026 CPL	
2	01142D	1		CILINDRO 125 MX/EN CARBURATORE MY 2026 NUDO	
3	48061	1		ANELLO TIPO PS DIN 988 19x26x1	
4	F03388	1		CUSCINETTO 61802-2RS1	BEARING 61802-2RS1
5	28271	1		ALBERO A CAMME PER CINEMATISMO VALVOLA DI SCARICO 2T SBS	
6	16263	1		MOLLA A TORSIONE D.INT. 9.3x1.3 St.9.6 SX R=1.531 Nmm/°	
7	F03389	1		CUSCINETTO 8X16X5 628/8 2RS1	BEARING 628/8 2RS 8x16x5
8	28268	3		BILANCIERE AZIONAMENTO VALVOLA SCARICO 2T	
9	F19504	2		RULLO D.4 X 8	PIN D.4 X 8
10	28074	1		SPINA CILINDRICA TEMPRATA DIN 7979 D - 6x80	
11	49717	1		GRANO 8 X 6	GRUB SCREW 6x8
12	49473	4		VITE TCEI 5X14	BOLT TCEI 5X14
13	12028	1		OR COP. POMPA H2O 2T 250/300 MY19 + 125 MY25	O-RING WATER PUMP COVER 2S 250/300 MY.18->
14	001269	1		COPERCHIO ISPEZIONE CINEMATISMO DI SCARICO 125 2T	
16	26269	2		PIATTELLO SUPERIORE PERNO BOOSTER	
17	16261	2		MOLLA A COMPRESSIONE MOLATA 32.0x17.8x1.1 St.6.0 K=0.770 N/mm	SPRING, BOOSTER 32.0x17.8x1.1 St.6.0 K=0.770 N/mm
18	26283	1		PIATTELLO INFERIORE BOOSTER ANTIROTAZIONE SINISTRO	
19	22096	1		SET BOOSTER VALVOLA DX+SX 125 2025 (22091% +22092%)	BOOSTERS, SET, RH+LH 2S 125 ES
20	26268	1		PIATTELLO SUPERIORE VALVOLA PARZIALIZZATRICE SCARICO	
21	16262	1		MOLLA A COMPRESSIONE MOLATA 32.0x16.45x1.25 St.6.75 K=1.420 N/mm	SPRING, EX. VALVE 32.0x16.45x1.25 St.6.75 K=1.420 N/mm
22	26266	1		PIATTELLO INFERIORE VALVOLA PARZIALIZZATRICE SCARICO	
23	16260	2		MOLLA A COMPRESSIONE 16.5x4.1x0.5 St.16 K=0.870N/mm	SPRING, COMPRESSION 16.5x4.1x0.5 St.16 K=0.870N/mm
24	22095.26	1		VALVOLA GHIGL. 125 ES 2026 (22089C+22097)	



2T125EN26-M
2T 125 EN ES - ENGINE

CILINDRO 02 - 125 MX/EN CARB
CYLINDER 02 - 125 MX/EN CARB.

2

Pos.	Codice	Q.tà	Note	Descrizione	Description
25	26284	1		PIATTELLO INFERIORE BOOSTER ANTIROTAZIONE DESTRO	
26	F48407.010	1		RONDELLA 5x10x0,10 PS DIN 988	
26	F48407.020	1		RONDELLA 5x10x0,20 PS DIN 988	
26	F48407.030	1		RONDELLA 5x10x0,30 PS DIN 988	
26	F48407.050	1		RONDELLA 5x10x0,50 PS DIN 988	
27	22089C	1		PRIMO STADIO VALVOLA PARZIALIZZATRICE SCARICO	
28	22097	1		SECONDO STADIO VALVOLA PARZIALIZZATRICE SCARICO MY26	



2T125EN26-M
2T 125 EN ES - ENGINE

ALBERO MOTORE E PISTONE
CRANKSHAFT AND PISTON

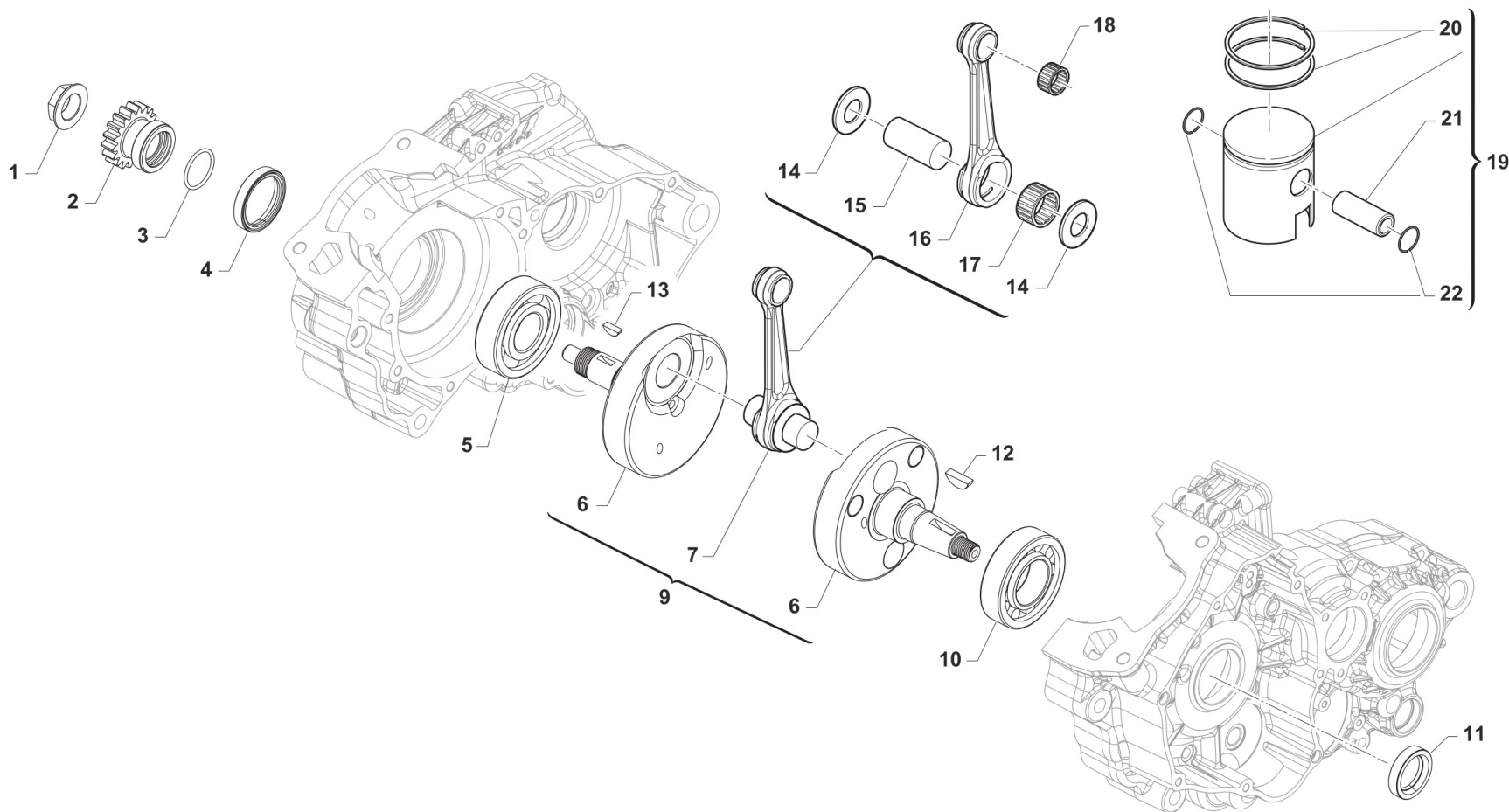

TM 0753



2T125EN26-M
2T 125 EN ES - ENGINE

ALBERO MOTORE E PISTONE
CRANKSHAFT AND PISTON

3

Pos.	Codice	Q.tà	Note	Descrizione	Description
1	F49816	1		DADO M18 x 1,25 SPECIALE	
2	40322	1		PIGNONE COPPIA PRIMARIA Z18 MY2023	
3	12067	1		O RING 23X2	
4	04049	1		PARAOLIO FPJ 32x41x7	
5	03255	1		CUSCINETTO A SFERE ALB.MOTORE 125 M.13	BUSH, CRANKSHAFT 125 M.13
6	18291	1		COPPIA SEMIALBERI 125 Fi ES 2025	
7	18125.2	1		BIELLA 125Fi ASSE 22 x 50,4 CPL ASSE F.5	CONROD ASSY2 125 Fi PIN 22 x 50,4 mm Hole 5mm
9	18297	1		ALBERO MOTORE CPL 125 Fi ES 2025	
10	03026.1	1		CUSCINETTO ALBERO MOTORE NJ206ET2XCS46	BEARING NJ206ET2XCS46
11	04039	1		PARAOLIO 22x33x7 PTFE	
12	49012.1	1		CHIAVETTA 19 x 7 x 5	
13	490035	1		LINGUETTA A DISCO UNI 6606 4x5	
14	18289	2		RONDELLA ARGENTATA D.22,2 X 35,1 X 1 SMUS. SOSTITUISCE 18239 + 18239.1	WASHER SILVER D.22,2 X 35,1 X 1 REPLACES CODES 18239 + 18239.1
15	18091.4	1		ASSE ACCOP. 22 X 50.4 F.5	CRANKPIN 22 X 50,4 hole 5mm
16	18053.2	1		BIELLA ASSE 22 FORG. NUDA 109,8	CONROD D.22mm FORGED 109,8
17	17016	1		GABBIA ARGENTATA 222815 R.SF.	
18	19034	1		GABBIA SPINOTTO 15X19X17,3	TOP END B. 15X19X17,3
19	10029.94	1		PISTONE 53.94 125 ES 2025 2F CPL	PISTON 53.94 125 ES 2025 2R COMP.
19	10029.95	1		PISTONE 53.95 125 ES 2025 2F CPL	PISTON 53.95 125 ES 2025 2R COMP.
19	10029.96	1		PISTONE 53.96 125 ES 2025 2F CPL	PISTON 53.96 125 ES 2025 2R COMP.
19	10029.97	1		PISTONE 53.97 125 ES 2025 2F CPL	PISTON 53.97 125 ES 2025 2R COMP.
19	10029.98	1		PISTONE 53.98 125 ES 2025 2F CPL	PISTON 53.98 125 ES 2025 2R COMP.
20	11078	2		SEGMENTO D. 54 X 0,8 RIKEN/NISMO	PISTON RING D.54 X 0,8 Riken
21	09000	1		SPINOTTO PISTONE VERTEX 125	PISTON PIN VERTEX 125

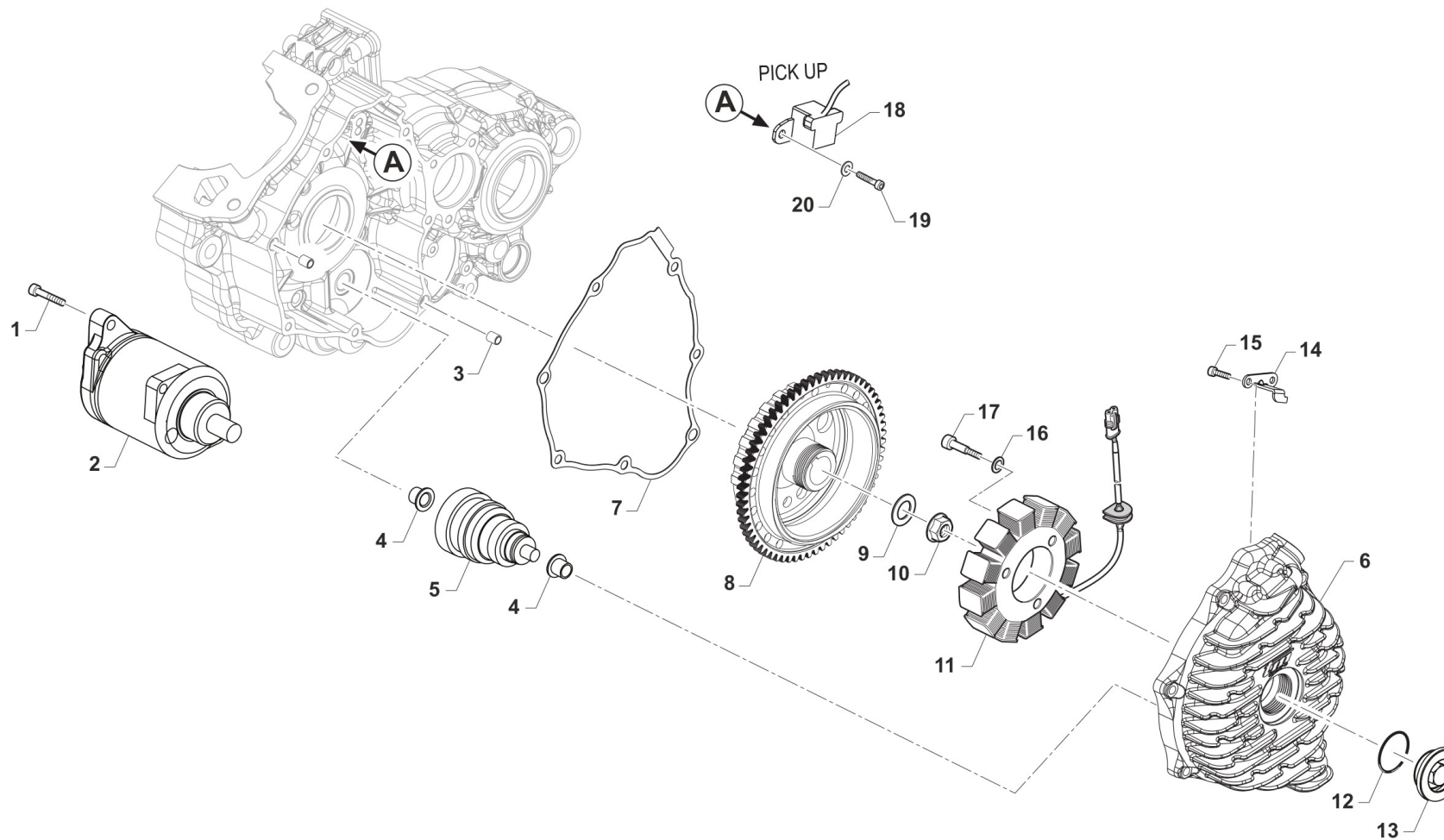

TM 0754.01



2T125EN26-M
2T 125 EN ES - ENGINE

ACCENSIONE 125 EN CARB
IGNITION 125 EN CARB

4

Pos.	Codice	Q.tà	Note	Descrizione	Description
1	49485	2		VITE TCEI 6X25 UNI 5931	BOLT TCEI 6x25
2	68206	1		MOTORINO AVVIAMENTO 250/300 M18->	STARTER MOTOR 250/300 T.S. MY19->
3	26041	2		GRANO CENTRAGGIO D.7X8 F.5,2	DOWEL PIN 7 x 8 Hole 5,2
4	26256	2		BOCCOLA FLANGIATA BENDIX AVV. EL. 250/300 2T I.E.	FLANGE BUSH BENDIX EL.ST. 250/300 T.S. Fi
5	68207	1		BENDIX MOTORE 250/300 2T ES MY 2019	BENDIX
6	30394	1		COPERCHIO ACCENSIONE 2T 125 Fi ES MY 2025 - 3 FORI	COVER, IGNITION, 2S 125 Fi ES MY25
7	05286	1		GUARNIZIONE COPERCHIO ACCENSIONE 2T 125 ES MY25	GASKET, IGNITION COVER 2S 125 ES MY 25
8	15252	1		ROTORE X GEN. ES 2T 125 Fi 2025 CPL C45	ROTOR, 2S 125 ES MY 25
9	49613	1		RONDELLA ACCIAIO 12	STEEL WASHER 12
10	49056	1		DADO ACCENSIONE MX/E 12 x 1.25	NUT, IGNITION 100cc
11	F15551	1		STATORE KOKUSAN YS 9022	STATOR KOKUSAN YS 9022
12	F12322	1		O RING 2106	O-RING
13	49290	1		TAPPO COPERCHIO ACC. 250/300 2T MY 2019(PUO' SOSTITUIRE F49833)	CAP IGNITION COVER 250/300 2S MY19
14	F30945	1		PROTEZIONE CAVI ACC.NE 250N	PROTECTION IGNITION WIRES 250N
15	49556	2		VITE TBCE 4X10	BOLT TBCE 4x10
16	49615	3		RONDELLA ACCIAIO 5x11x0,5	WASHER STEEL 5 mm
17	49477	3		VITE TCEI 5X25 UNI 5931-912	BOLT TCEI 5X25
18	F15478	1		PICK-UP KOKUSAN	PICK-UP KOK PU5157
19	49472	2		VITE TCEI 5X12 UNI 5931-912 Brun	BOLT TCEI 5X12
20	49601	2		RONDELLA 5X11	WASHER 5x11



2T125EN26-M
2T 125 EN ES - ENGINE

FRIZIONE
CLUTCH

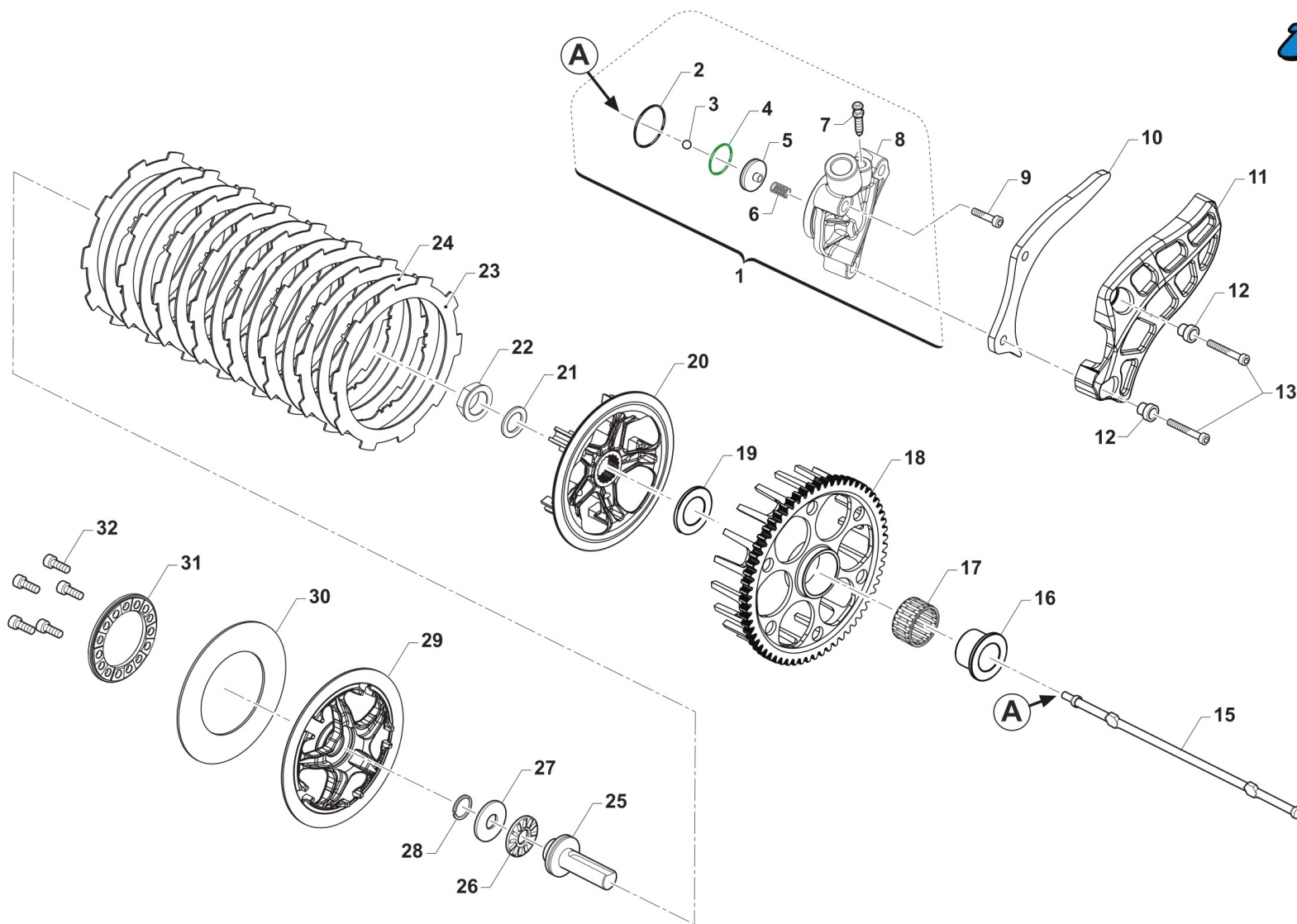

TM 0752



2T125EN26-M
2T 125 EN ES - ENGINE

FRIZIONE
CLUTCH

Pos.	Codice	Q.tà	Note	Descrizione	Description
1	30375	1		ATTUATORE FRIZ. Ø26 125 ES MX/EN MY 25 CPL	OUTPUT HYDR. CLUTCH 2S 125 ES MX/EN ASSY
2	12243	1		O RING NBR 2112 28.30x1.78	
3	F19517	1		SFERA X PIST.FRIZ.IDRAUL.250N	BALL IDR. CLUTCH PISTON 250N
4	12259	1		O RING PISTONE FR.125/250 VITON (Verde)	O-RING, CLUTCH PISTON 125/250
5	F35554	1		PISTONCINO POMPA FRIZIONE	PISTON CLUTCH MASTER CYLINDER
6	F16470	1		MOLLA CONTR. PIST/FRI 450Fi'15	
7	35264	1		VITE SPURGO OLIO FRIZ.IDR.6X1	SCREW AIR BLED HYDRAUL.CLUTCH
8	30371	1		CORPO ATTUATORE FRIZ. Ø26 125 MY 25	
9	49477	1		VITE TCEI 5X25 UNI 5931-912	BOLT TCEI 5X25
10	40042	1		PROTEZIONE PIGNONE ERGAL 250/300 2T ES MY 2019	PROTECTION, ERGAL
11	40075	1		PROTEZIONE PIGNONE 250/300 ES + 125 es	PROTECTION, PLASTIC
12	26211	2		BOCCOLA PROT. PIGNONE 250 F.5	COLLAR, SPROCKET 250cc H.5
13	49535	2		VITE TCEI 5X35 UNI 5931-912	BOLT TCEI 5X35
15	35067	1		ASTINA FRIZIONE IDRAULICA 125 ES MY 2025	ROD, CLUTCH 2S 125 ES
16	26197	1		BOCCOLA INGR.TRASM.PRIM. 125 2022	COLLAR, CLUTCH OUTER 2S 125 ES
17	19111	1		GABBIA A RULLI K26x30x17	BEARING, NEEDLE, 26x30x17
18	40323	1		COPPIA PRIM. 125 Z63 MY2023	
19	48048	1		SPESSORE INGR.TRASM. PRIM.125 2022 (20X34.8X2.5)	SPACER, OUTER CLUTCH, 20x34,8x2,5
20	25101	1		TAMBURELLO FRIZIONE	
21	490059	1		RONDELLA SCHNORR DIN9250 - M18/19x27x1.5	
22	490058	1		DADO Ø27.5 - M18 x 1,5 - 125 ES	
23	35056	8		DISCO FRIZ. GUARN. 2T 125 ES MX/EN MY 2025	DISK, CLUTCH 2S 125 ES
24	35055	7		DISCO FRIZ. ACC. 2T 125 ES SP.1,2 MY 25	
25	F35582	1		FUNGO FRIZIONE IDRAULICA 2015	PIECE, CLUTCH LIFTER
26	19022	1		GABBIA A RULLI RAD. AXK 1528	BUSH CAGE AXK 1528, RADIAL
27	19023	1		RONDELLA GABBIA RULLI AS 1528	WASHER, NEEDLE CAGE AS 1528
28	09006	1		ANELLINO FERMA SPINOTTO 80/85/100	CLIP, PISTON PIN 80/85/100cc
29	25102	1		SPINGIDISCO FRIZIONE	



2T125EN26-M
2T 125 EN ES - ENGINE

FRIZIONE
CLUTCH

5

Pos.	Codice	Q.tà	Note	Descrizione	Description
30	16077	1		MOLLA FRIZIONE 2T 125 ES MY 25	SPRING, CLUTCH 2S 125 ES MY25
31	25103	1		ELEMENTO FISSAGGIO MOLLA FRIZIONE	
32	49473	1		VITE TCEI 5X14	BOLT TCEI 5X14



2T125EN26-M
2T 125 EN ES - ENGINE

CARTER FRIZIONE
CLUTCH CASE

6

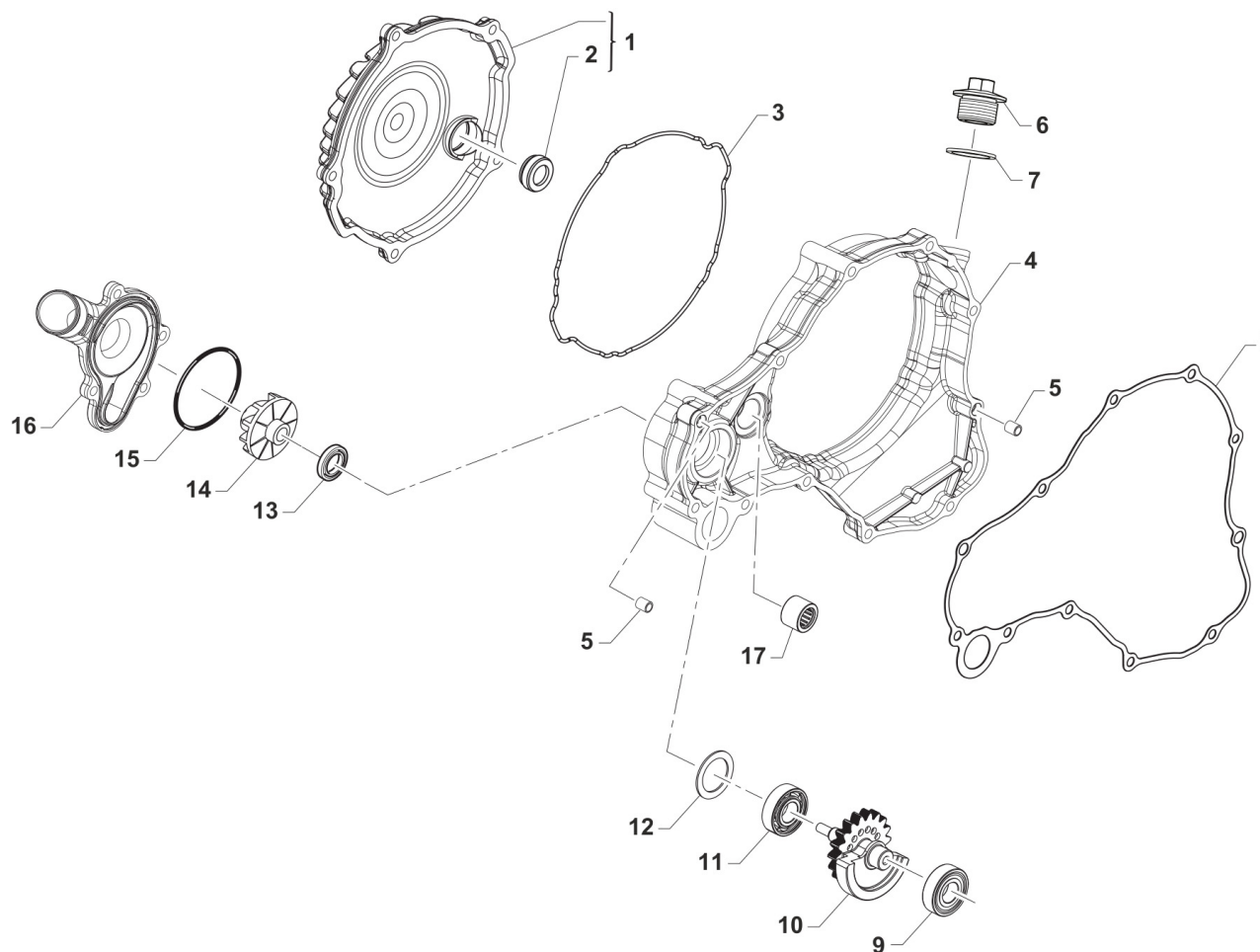

TM 0756



2T125EN26-M
2T 125 EN ES - ENGINE

CARTER FRIZIONE
CLUTCH CASE

6

Pos.	Codice	Q.tà	Note	Descrizione	Description
1	30370.1	1		COPERCHIO FRIZIONE 125 MY 2025 COMPLETO DI OBLO' 04019	COVER, CLUTCH, 2S 125 ES MY25
2	04019	1		OBLO' OLIO 125 - LIVELLO OIL Fi 2T	OIL WINDOW 125 ES MY25
3	12270	1		O RING SAGOMATO COP. FRIZIONE 125 FI 2T 2025	
4	30369	1		CARTER FRIZIONE 125 2T MY 2025	
5	26041	2		GRANO CENTRAGGIO D.7X8 F.5,2	DOWEL PIN 7 x 8 Hole 5,2
6	F49844	1		TAPPO CARICO OLIO 250N	
7	F49920	1		RONDELLA ALL 20.4X26X1.5	WASHER 20,4X26X1,5 ALUM.
8	05287	1		GUARNIZIONE CARTER FRIZIONE 2T 125 ES MY25	GASKET, CLUTCH CASE 2S 125 ES MY 25
9	03094	1		CUSCINETTO A SFERE 12x28x8 6001-2RSH/C3	
10	40324	1		INGRANAGGIO POMPA ACQUA E CONTRALBERO 125 ES MY2025	
11	03093	1		CUSCINETTO A SFERE 12x28x8 6001 C4	
12	48062	1		RONDELLA 20x28x1 PS DIN 988	
13	F04363	1		PARAOLIO 8X22X5 250/09->	OIL SEAL 8x22x5 (250F/09)
14	F28679	1		GIRANTE POMPA ACQUA 250N	IMPELLER, H2O PUMP 250Fi
15	12046	1		X-RING QUADRING 2250 = 2.37 (63.22x1.78)	
16	30393	1		COPERCHIO POMPA ACQUA 125 MY 2025	
17	03092	1		CUSCINETTO A RULLINI 10x17x12	



2T125EN26-M
2T 125 EN ES - ENGINE

BASAMENTO E PACCO
CASE AND REEDS BOX

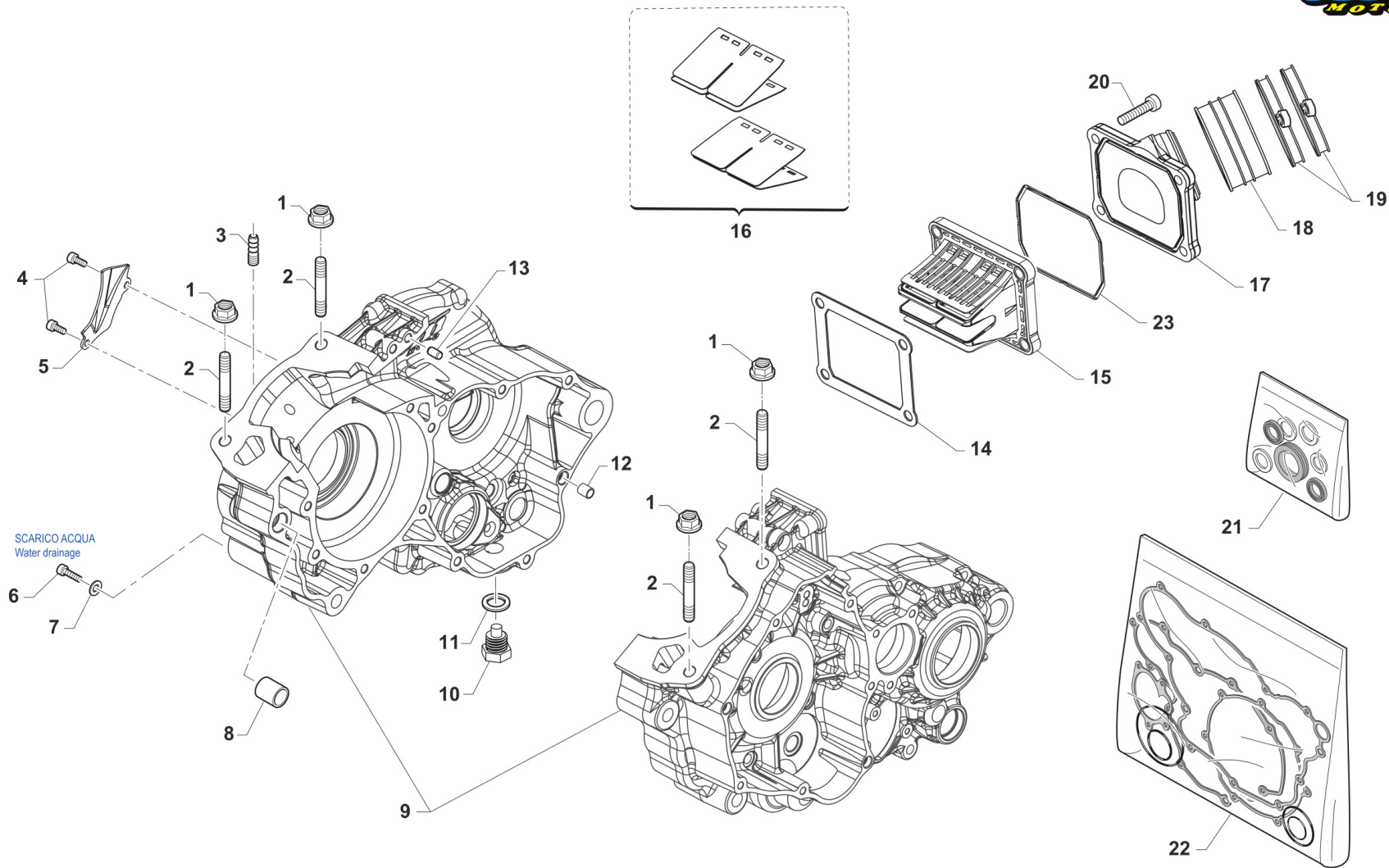

TM 0757



2T125EN26-M
2T 125 EN ES - ENGINE

BASAMENTO E PACCO
CASE AND REEDS BOX

7

Pos.	Codice	Q.tà	Note	Descrizione	Description
1	49191	4		DADO M 8 X 1,25 CH. 10 FLANGIATO	NUT, FLANGE M8 x 1,25
2	49028	4		PRIGIONIERO CILINDRO M 8 X 52 125 2025	
3	49004	1		RACCORDO SFIATO CARTER	PIPE, CRANKCASE BREATHER
4	490050	2		VITE TBCIX 4X8 TORX	
5	26162	1		PIASTRINO CONV.OLIO 250/300 18	PLATE
6	49480	1		VITE TCEI 6X10 UNI 5931	BOLT TCEI 6X10
7	49104	1		RONDELLA 6 x 10 x 1,5 ALLUMINIO	WASHER 6 x 10 x 1.5 ALUMINUM
8	F26428	1		GRANO RIFERIMENTO 12X13 F10.2	GRUB SCREW 12X13 H.10,2mm
9	30367	1		BASAMENTO MOTORE 2T 125 ES MY 2025	
10	49301	1		TAPPO OLIO C/CALAM. 2T	OIL PLUG WITH MAGNET
11	49103	1		RONDELLA 14X20X1,5 ALLUMINIO	WASHER, 14 X 20 X 1.5 ALUMINUM
12	F26304	1		GRANO RIFERIMENTO 6.1X8X9.5 4T	GRUB SCREW 6.5X8XX9.5 4S
13	19006	1		RULLINO 5 X 8	PIN 5 X 8, CLUTCH ROD
14	05631	1		GUARN. PACCO LAMELLE VFORCE 3 E VFORCE 4X	GASKET, REEDS BOX 2S 125 ES MY25
15	20259	1		PACCO LAMELLARE V-FORCE 4X TM	
16	20098	1		LAMELLE V-FORCE 4X 125 2025	
17	13129	1		COLLETTORE ASPIRAZIONE 125 2T CARBURATORE	
18	13009	1		MANICOTTO COLLETTORE ASP.97/14	MANIFOLD RUBBER,INTAKE M.97/14
19	51054	2		FASCETTA SM9 D.52	CLAMP SM9 D.52mm
20	49538	4		VITE TCEI 6X22 UNI 5931	
21	04046	1		KIT PARAOLI 125 ES MY 2025	
22	05632	1		KIT GUARN. + OR 125 ES MY 2025	GASKETS + OR KIT 2S 125 ES MY25
23	12026.1	1		O RING CONVOGLIATORE 125 13086	O-RING INLET MANIFOLD 125 13086



2T125EN26-M
2T 125 EN ES - ENGINE

COMANDO CAMBIO
GEARSHIFT MECHANISM

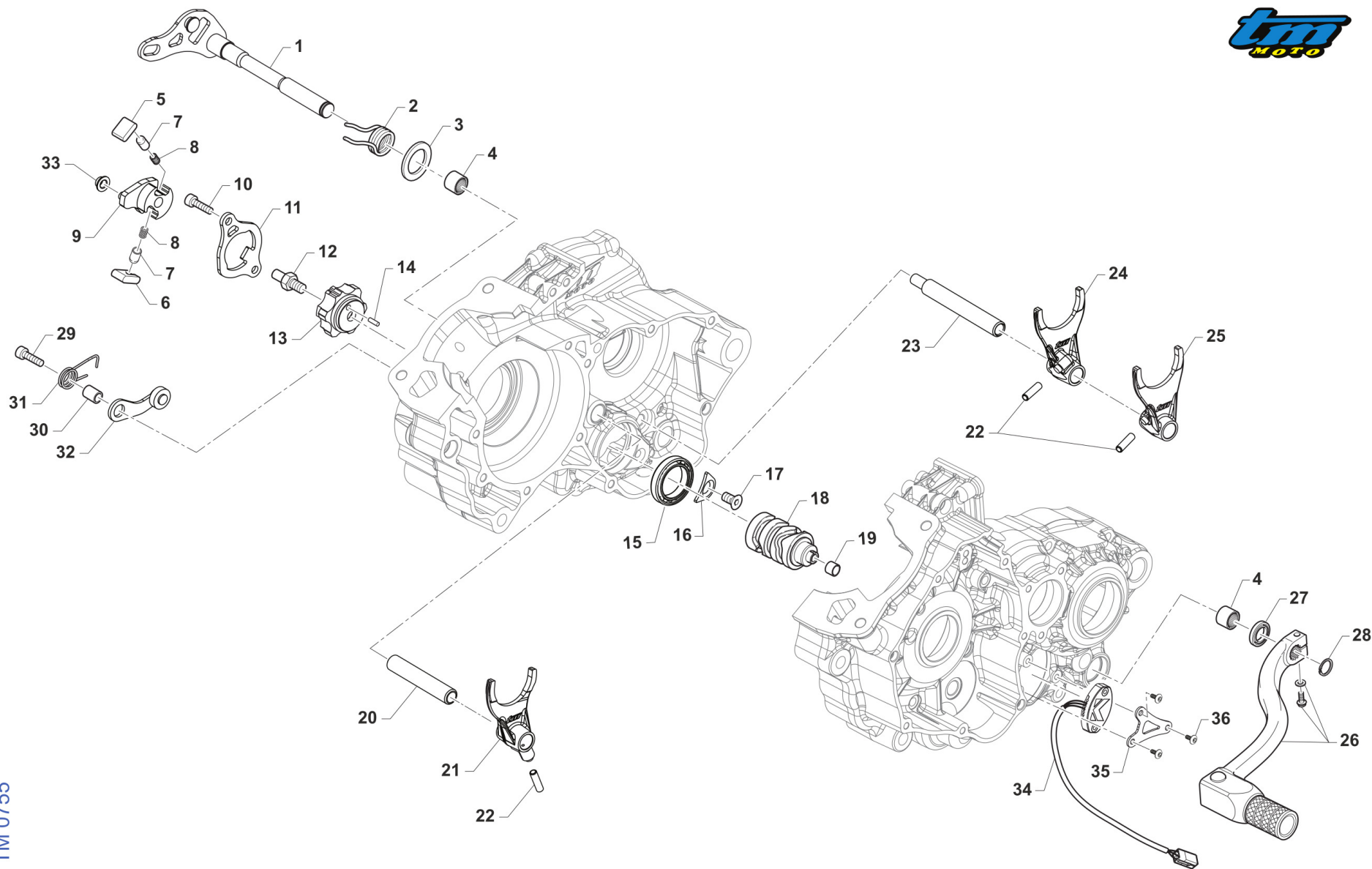

TM 0755



2T125EN26-M
2T 125 EN ES - ENGINE

COMANDO CAMBIO
GEARSHIFT MECHANISM

Pos.	Codice	Q.tà	Note	Descrizione	Description
1	28105	1		ALBERO COMANDO CAMBIO 250/300 IE CPL	SHAFT, GEARSHIFT 250/300 IE CPL
2	16065	1		MOLLA RITORNO LEVA CAMBIO 250 2T IE	SPRING, RETURN GEAR LEVER 250 2S EI
3	49073	1		RONDELLA 12,1X22X1	WASHER 12,1X22X1 125 MF1/2
4	19060	2		ASTUCCIO A RULLI HK 1212	NEEDLE CAGE HK 1212
5	F26587	1		CRICCHETTO SX 2T 250/300 ES	RATCHET, LF GEAR (HT) 250 M3
6	F26588	1		CRICCHETTO DX 2T 250/300 ES	RATCHET, RH GEAR (HT) 250 M3
7	F26592	2		PUNTALE CRICCHETTO 2T 250/300 ES	PIN, RATCHET GEAR (HT)
8	F16469	2		MOLLA PER PUNTALE 2T 250/300 ES	SPRING, GEARBOX PIN EDM
9	F26620	1		PORTACRICCHETTI HT 2T 250/300 ES	GEAR
10	49481	2		VITE TCEI 6X12	BOLT TCEI 6X12
11	26160	1		PIASTRINO RIENTRO CRIC.250 M18	PLATE
12	F49873	1		PERNO FILETTATO PORTACRICCHETTI (HT) 2T 250/300 ES	THREADED PIN FOR RATCHET HOLDER (HT)
13	26181	1		TESTA ALBERO DESMO ROT.D12 125/144 2T M22	
14	F19504	1		RULLO D.4 X 8	PIN D.4 X 8
15	F03381	1		CUSCINETTO 61805	BEARING 61805
16	F48352	1		PIASTRINO FISSA CUSCINETTO D72	PLATE
17	49403	1		VITE TSEI 6X12 ZINCATO	SCREW TSEI 6x12
18	33262	1		ALBERO DESMO 2T 125 ES 6M CPL MY 2025	
19	26260	1		BOCCOLA ALB. DESMODROMICO 250/300 2T I.E.	BUSH
20	33260	1		PERNO FORCHETTA AP 250/300 MY19	PIN, MAINSHAFT FORK
21	33028	1		FORCHETTA ALB.PRIM. 125/144 2T 5^/6^ (2022)	FORK, MAINSHAFT 2S 125 ES
22	F19533	3		RULLO D.6 X 15	PIN
23	33025	1		PERNO FORCHETTA AS 250/300 MY19	PIN, COUNTERSHAFT FORKS
24	33023	1		FORCHETTA A.S.1^3^ 250/300 M18 1A E 3A	FORK 1, COUNTERSHAFT
25	33027	1		FORCHETTA ALB.SEC. 250/300 2T 6M 2^/3^ (2020)	FORK 2, COUNTERSHAFT
26	43049	1		LEVA CAMBIO 2T (485)	GEAR LEVER 2S [485]
27	04038	1		PARAOLIO LEVA CAMBIO 250/300 2T I 12x20x5 l.parapolv.	OIL SEAL GEAR LEVEL 250/300 2S Fi 12x20x5
28	49212	1		SEEGER E12 LEVA CAMBIO	CIRCLIP D.12 - EXTERNAL



2T125EN26-M
2T 125 EN ES - ENGINE

COMANDO CAMBIO
GEARSHIFT MECHANISM

8

Pos.	Codice	Q.tà	Note	Descrizione	Description
29	49485	1		VITE TCEI 6X25 UNI 5931	BOLT TCEI 6x25
30	26007	1		DISTANZIALE MOLLA BLOCCAMARCE	SPACER, STOP GEAR SPRING
31	F16447.3	1		MOLLA BLOCCA MARCE 250 4T D.FILO 2.4	
32	26095	1		PIASTRINO BLOCCAMARCE KV/95CPL + MOTO	PLATE, STOP GEAR KV/95 ASSY
33	F26593	1		BOCCOLA FLANGIATA PORTACRICCHETTO F26620	LEVER BUSH
34	F08459	1		SENSORE POSIZIONE CAMBIO eM060 CPL G.ANTIORARIO	
35	26280	1		PIASTRINO FISSAGGIO SENSORE POSIZIONE CAMBIO 125 2T	
36	490050	3		VITE TBCIX 4X8 TORX	



2T125EN26-M
2T 125 EN ES - ENGINE

CAMBIO EN/SMR
GEARBOX

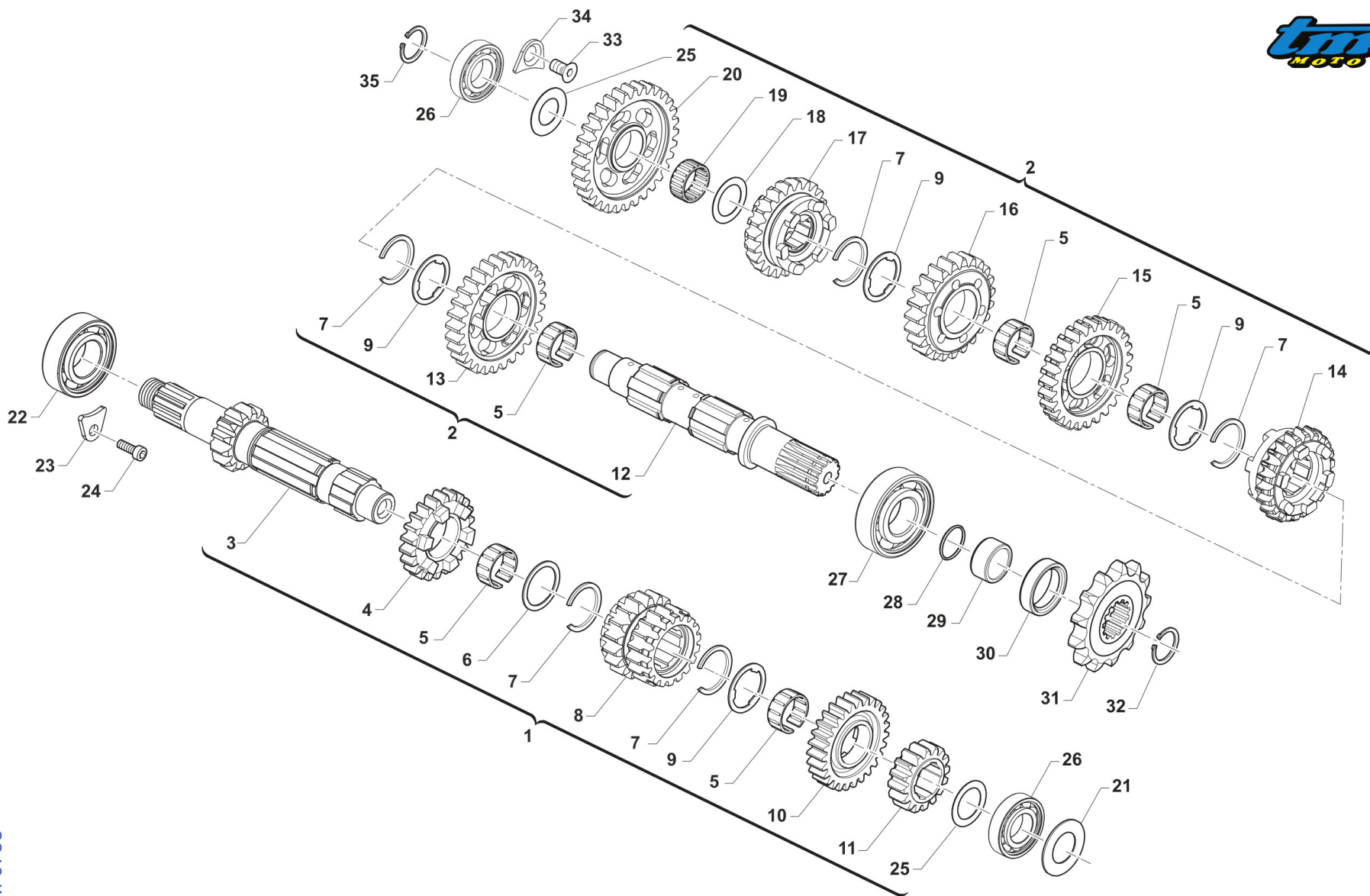

TM 0758



2T125EN26-M
2T 125 EN ES - ENGINE

CAMBIO EN/SMR
GEARBOX

Pos.	Codice	Q.tà	Note	Descrizione	Description
1	40084	1		ALBERO PRIM. CPL 125 ES 2025 END/SMR	
2	40085	1		ALBERO SECOND. CPL 125 ES 2025 END/SMR	
3	40721	1		ALBERO PRIMARIO Z 13 125FI 2T EN 2020	
4	40724	1		INGR A.P. 5a Z 21 125FI 2T MX/EN 2020	
5	F19524	5		GABBIA A RULLI 22X26X10 TAGL.	NEEDLE BEARING 22 X 26 X 10
6	48259	1		SPESSORE D.25.1 x 31 x 1.5 CAMBIO INT.55 6M	
7	F49869	5		SEEGER SW 24 (EST.) "SEEGER"	CIRCLIP SW 24 (EXTERNAL)
8	40723	1		INGR A.P. 3/4a Z 18/18 125FI 2T MX/EN 2020	
9	48258	4		SPESSORE DENT.CAMBIO INT.55 6M	SPACER GEAR INT.55 6S
10	40726	1		INGR A.P. 6a Z 22 125FI 2T EN 2020	
11	40722	1		INGR A.P. 2a Z 16 125FI 2T MX/EN 2020	
12	40727	1		ALBERO SECONDARIO 125FI 2T MX/EN 2020	
13	40730	1		INGR A.S. 2a Z 29 125FI 2T MX/EN 2020	
14	40735	1		INGR A.S. 6a Z 20 125FI 2T EN 2020	
15	40731	1		INGR A.S. 3a Z 27 125FI 2T MX/EN 2020	
16	40732	1		INGR A.S. 4a Z 23 125FI 2T MX/EN 2020	
17	40733	1		INGR A.S. 5a Z 23 125FI 2T MX/EN 2020	
18	F48353	1		SPESSORE PS 18X25X1	SPACER 18x25x1
19	F19514	1		GABBIA A RULLI 18X22X10	NEEDLE CAGE 18X22X10
20	40729	1		INGR A.S. 1a Z 32 125FI 2T EN 2020	
21	48063	1		RASAMENTO Ø17,3 x Ø32,9 x 0,30	
22	03164.1	1		CUSCINETTO SFERE (20x42x12) 6004 C3	BEARING (20x42x12) 6004 C3
23	26156	1		PIASTRINO BLOC.CUSC.C.A.125 OK /250/300	PLATE, BEARING HOLDER 125 OK
24	49962	1		VITE TCEI 6X12 BASSA / F.GUIDA	BOLT
25	48253	2		SPESSORE CAMBIO 17X30X1 250	SPACER, GEAR BOX 250cc 17X30X1
26	03165	2		CUSCINETTO SFERE (17x35x8) 16003 C3	BEARING (17x35x8) 16003 C3
27	F03368	1		CUSCINETTO 62/22 C3 22x50x14	BEARING 62/22 C3 22x50x14
28	F12320	1		O RING BOCCOLA PIGNONE 250/09	O-RING NBR 2087



2T125EN26-M
2T 125 EN ES - ENGINE

CAMBIO EN/SMR
GEARBOX

Pos.	Codice	Q.tà	Note	Descrizione	Description
29	F26421	1		DISTANZ. PIGNONE CATENA 250N	SPACER SPROCKET CHAIN 250N
30	04113	1		PARAOLIO 28 X 38 X 7	OIL SEAL 28 x 38 x 7
31	F40889	1		PIGNONE CATENA 4T250/300N + 125 ES - Z 13	SPROCKET 13T, DRIVE 250Fi
31	F40933	1		PIGNONE CATENA 4T250/300N + 125 ES - Z 14	SPROCKET 14T, DRIVE 250Fi
31	F40956	1		PIGNONE CATENA 4T250/300N + 125 ES - Z 12	SPROCKET 12T, DRIVE 250Fi
32	49217	1		SEEGER E22 ANELLO ALB/S	CIRCLIP D.22 - COUNTERSHAFT
33	49403	1		VITE TSEI 6X12 ZINCATO	SCREW TSEI 6x12
34	F48352	1		PIASTRINO FISSA CUSCINETTO D72	PLATE
35	49253	1		SEEGER E 17	CIRCLIP, INTERMED.GEAR K.S.250



2T125EN26-M
2T 125 EN ES - ENGINE

VITI MOTORE
BOLTS

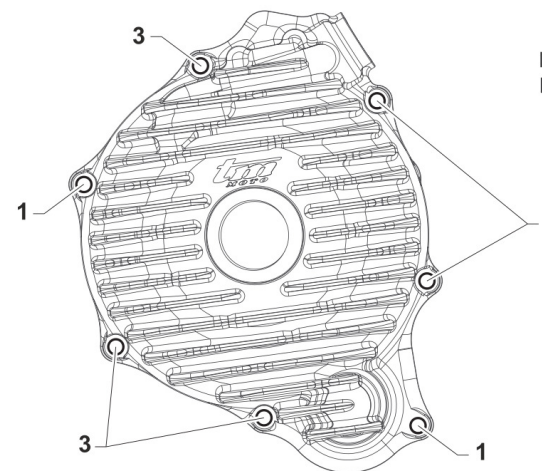
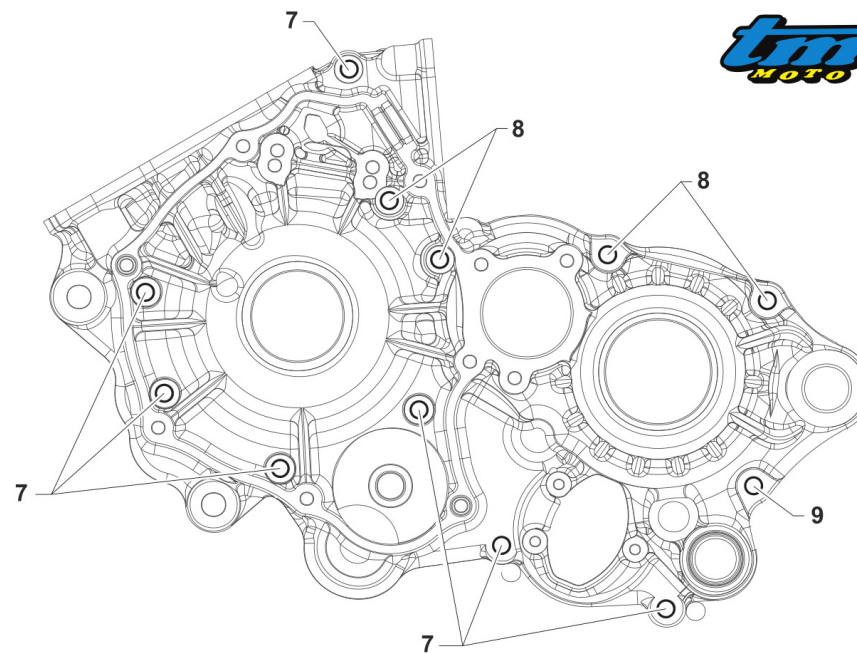
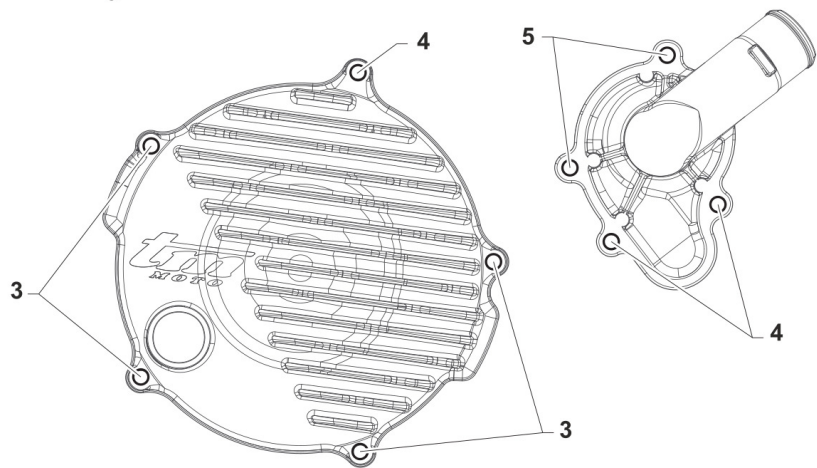
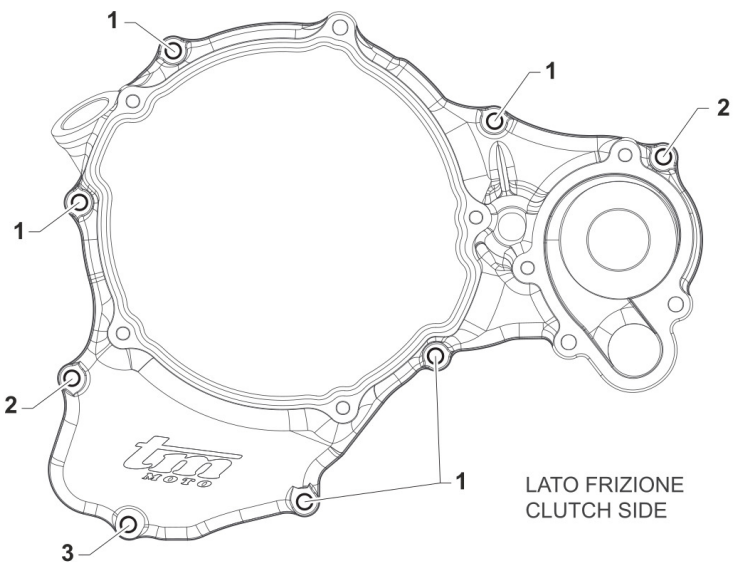

TM 0759



2T125EN26-M
2T 125 EN ES - ENGINE

VITI MOTORE
BOLTS

10

Pos.	Codice	Q.tà	Note	Descrizione	Description
1	49477	7		VITE TCEI 5X25 UNI 5931-912	BOLT TCEI 5X25
2	49478	2		VITE TCEI 5X30 UNI 5931	BOLT TCEI 5X30
3	49476	10		VITE TCEI 5X20 UNI 5931-912	BOLT TCEI 5X20
4	49578	3		VITE TCEI 5X55	BOLT TCEI 5X55
5	49474	2		VITE TCEI 5X16 UNI 5931	BOLT TCEI 5X16
7	49489	7		VITE TCEI 6X45 UNI 5931	BOLT TCEI 6x45
8	49491	4		VITE TCEI 6X55	BOLT TCEI 6X55
9	49492	1		VITE TCEI 6X60	BOLT TCEI 6X60